

# **Model NCB-IS**

## **Network Combiner Module with ISDN Modem**

Wide Area Router for LONWORKS® Networks

**User Guide # S2-60832-305**



**Standard Limited Hardware Warranty**

**LIMITED WARRANTY.** Equipment manufactured by CTI Products, Inc. is warranted to be free from defects in material and workmanship for a period of ONE (1) YEAR from date of shipment to original purchaser. Under this warranty, our obligation is limited to repairing or replacing any equipment proved to be defective by our inspection within one year of sale to the original purchaser. This warranty shall not apply to equipment which has been repaired outside our plant in any way, so as to, in the judgment of CTI Products, Inc. affect its stability or reliability, nor which has been operated in a manner exceeding its specifications, nor which has been altered, defaced, or damaged by lightning.

**CUSTOMER REMEDIES.** In the event of a defect, malfunction, or failure to conform to specifications established by the seller during the period shown, the customer shall call CTI Products, Inc. to obtain a Return Authorization Number and return the product or module, shipping and insurance prepaid. CTI Products, Inc., will then at its option, either repair or replace the product or module and return it, shipping prepaid, or refund the purchase price thereof. On-site labor at the purchaser's location is not included in this warranty.

**EQUIPMENT NOT MANUFACTURED BY CTI Products, Inc.** Equipment not manufactured by CTI Products, Inc. is excluded from this warranty, but is subject to the warranty provided by its manufacturer, a copy of which will be supplied to you upon specific written request.

**NO OTHER WARRANTIES.** The foregoing constitutes the sole and exclusive remedy of the buyer and exclusive liability of CTI Products, Inc., AND IS IN LIEU OF ANY AND ALL OTHER WARRANTIES EXPRESSED OR IMPLIED OR STATUTORY AS TO MERCHANTABILITY, FITNESS FOR PURPOSE SOLD, DESCRIPTION, QUALITY, PRODUCTIVENESS OR ANY OTHER MATTER.

**NO LIABILITY FOR CONSEQUENTIAL DAMAGES.** WITHOUT LIMITING THE FOREGOING, IN NO EVENT SHALL CTI PRODUCTS, INC. OR ITS SUPPLIERS BE LIABLE FOR ANY DAMAGES WHATSOEVER (INCLUDING, WITHOUT LIMITATION, SPECIAL, INCIDENTAL OR CONSEQUENTIAL DAMAGES OR FOR LOSS OF BUSINESS PROFITS, BUSINESS INTERRUPTION, LOSS OF BUSINESS INFORMATION, OR OTHER PECUNIARY LOSS) ARISING OUT OF THE USE OF OR INABILITY TO USE CTI PRODUCTS, INC. EQUIPMENT BY PURCHASER OR OTHER THIRD PARTY, WHETHER UNDER THEORY OF CONTRACT, TORT (INCLUDING NEGLIGENCE), INDEMNITY, PRODUCT LIABILITY OR OTHERWISE, EVEN IF CTI PRODUCTS, INC. HAS BEEN ADVISED OF THE POSSIBILITY OF SUCH DAMAGES OR LOSSES. IN NO EVENT SHALL CTI PRODUCTS, INC.'S, LIABILITY EXCEED THE TOTAL AMOUNT PAID BY PURCHASER FOR THE EQUIPMENT GIVING RISE TO SUCH LIABILITY.

**Radio Frequency Emissions and Immunity**

This equipment generates, uses, and can radiate radio frequency energy and, if not installed and used in accordance with the instruction manual, may cause harmful interference to radio communications. Operation of this equipment in a residential area is likely to cause harmful interference in which case the user will be required to correct the interference at his own expense. Changes or modifications to this unit not expressly approved by the party responsible for compliance could void the user's authority to operate the equipment. Limits specified in the standards listed below are designed to provide reasonable protection against harmful interference when the equipment is operated in a commercial environment.

**UNITED STATES:** This equipment has been tested and found to comply with the limits for a Class A digital device, pursuant to Part 15 of the FCC Rules.

**CANADA:** This Class A digital apparatus meets all requirements of the Canadian Interference-Causing Equipment Regulations.

Cet appareil numérique de la classe A respecte toutes les exigences du Règlement sur le matériel brouilleur du Canada.

**EUROPE:** This equipment has been tested and found to conform with the following standards: EN60950, EN50082-1, IEC801-2, IEC801-3, IEC801-4, and EN55022. This equipment complies with the requirements of the following directives: Low Voltage Directive 73/23/EEC, EMC Directive 89/336/EEC, and 93/68/EEC Harmonization of CE Marking

*Location:* **CTI Products, Inc**  
1211 West Sharon Road  
Cincinnati, OH 45240 USA

*Phone:* +1.513.595.5900

*Fax:* +1.513.595.5983

*Web:* [www.ctiproducts.com](http://www.ctiproducts.com)

*E-mail, Sales:* [info@ctiproducts.com](mailto:info@ctiproducts.com)

*Technical Support:* [lwsupport@ctiproducts.com](mailto:lwsupport@ctiproducts.com)

---

*This manual covers NCB units of Revision 300 or higher and NCB/Plug software revision 1.00 or higher. The NCB Unit Revision can be found on the rear of the unit following the letter "U". The NCB/Plug software revision can be found on the Help/About screen of the program. If the revision of the product in hand is greater than that shown above, there may be additional features supported by the product that are not covered in this manual.*

---



Information contained in this document is subject to change without notice and does not represent a commitment on the part of CTI Products, Inc.

No part of this manual may be reproduced or transmitted in any form or by any means, electronic or mechanical, including photocopying and recording, for any purpose without the written permission of CTI Products, Inc.

This manual describes products that include copyrighted CTI Products, Inc. computer programs in semiconductor memory. CTI Products, Inc. reserves all rights for these programs, including the exclusive right to copy or reproduce the copyrighted computer programs in any form. No copyrighted computer program contained in products described in this manual may be copied, reproduced, decompiled, disassembled, or reversed engineered in any manner without express written permission of CTI Products, Inc. The purchase of products from CTI Products, Inc. shall not be deemed to grant either directly or by implication, estoppel, or otherwise, any license under the copyrights, patents, or patent applications of CTI Products, Inc., except for the normal non-exclusive, royalty fee license to use that arises by operation of law in the sale of the product.

Copyright (c) 1995-2001 CTI Products, Inc. All rights reserved  
NCB Module and WON are trademarks of CTI Products, Inc.

Echelon, LON, LONWORKS, LONTALK, LONMARK, and Neuron are U.S. registered trademarks of Echelon Corporation.



# TABLE OF CONTENTS

<b>QUICK-START GUIDE .....</b>	<b>1</b>
<b>1. INTRODUCTION.....</b>	<b>3</b>
WHAT IS AN NCB/IS UNIT?.....	3
REFERENCE DOCUMENTS.....	5
FRONT PANEL .....	6
REAR PANEL.....	7
<b>2. SETUP AND OPERATION .....</b>	<b>9</b>
STEP 1. MOUNTING.....	9
STEP 2. SWITCH SETUP .....	9
STEP 3. ELECTRICAL CONNECTIONS .....	11
STEP 4. MODEM CONFIGURATION.....	12
STEP 5. IMPLEMENTATION IN A NETWORK.....	13
STEP 6. CONTROLLING THE WAN CONNECTION .....	16
<b>3. NETWORK VARIABLE (NV) CONTROL.....</b>	<b>17</b>
TYPICAL NV BINDINGS .....	17
MODEM CONTROLLER OBJECT .....	18
TELEPHONE DIRECTORY OBJECT .....	24
GLOBAL CONTROL OBJECT.....	25
<b>4. NCB/PLUG CONFIGURATION PLUG-IN.....</b>	<b>27</b>
INSTALLATION.....	27
ACCESSING NCB/PLUG.....	28
USAGE .....	28
<b>APPENDIX.....</b>	<b>31</b>
APPENDIX A. FACTORY DEFAULT CONFIGURATION .....	31
APPENDIX B. MOUNTING OPTIONS .....	33
APPENDIX C. CONNECTOR DETAILS .....	36
APPENDIX D. NCB VERSION COMPARISON .....	38
APPENDIX E. TROUBLESHOOTING.....	39
APPENDIX F. SPECIFICATIONS.....	43
APPENDIX G. MODEM NOTES .....	44
APPENDIX H. RING MODE .....	46
<b>INDEX.....</b>	<b>49</b>



# QUICK-START GUIDE

This Quick Start Guide provides a concise series of steps to get a pair of the NCB modules “up and running” quickly so that initial operation may be confirmed.

It is important that all LonWorks devices attached to the “NETWORK” connector of any one NCB module use the same network transceiver. See “LONWORKS NETWORK TRANSCEIVERS” in section “1. INTRODUCTION”.

In the following steps, identify the two units as “NCB Unit 1” and “NCB Unit 2”.

## Switch Settings

- Set the switches on the NCB units as follows:  
**BAUD 1 : 8    BAUD 2 : 0    MODE 1 : 6    MODE 2 : 6**  
**OPTION B Switches 1 through 4 : UP**  
**OPTION A Switches 1 through 4 and 6 through 8 : UP**  
**OPTION A Switch 5 : DOWN**

## ISDN Modem Configuration

Configuration of both ISDN modems must be performed before connecting them to the NCB module. Refer to Section 3.1 of the “NCB-ISDN User Documentation” (S2-60832-xxx) for instructions on how to complete this configuration. *This configuration process must be completed before proceeding with this quickstart procedure.*

If the switch type at the telephone company’s central office is ‘EuroISDN’, and the ISDN modem used is Multitech model MTA128ST, no configuration of the ISDN modem is needed.

Configuration for all other instances of the ISDN modem must be performed before it can communicate with the NCB module. See “STEP 4. MODEM CONFIGURATION” of Section “2. SETUP AND OPERATION”

## Module Connection

- Connect LonWorks network devices to the “NETWORK” connectors of each NCB unit (both RJ45s and the terminal strip are in parallel). If using the RJ45 connector(s), connect to pins 1 & 2 (the right-most two pins) and use caution, as other pins on these connectors carry DC power.
- Connect the DB25 connector on the ISDN modem to the “PORT 1” connector on the rear of the NCB unit using the cable supplied with the NCB.
- Connect each ISDN modem to a standard *ISDN* telephone line or PBX port using the cord provided with the modem.
- Connect power to the modems (and switch them on), and to the NCB units via the front panel “DC IN” connector. The units can be powered-up in any sequence. Both NCB Unit “ERR” LEDs will begin to flash.

**NOTE:** It is normal for the NCB Unit ERR LED to flash quickly for up to 30 seconds after power-up or reset of a fully configured and connected NCB-ISDN module. This indicates that the NCB is in the process of connecting to any external modems configured for use. A problem is indicated only if the ERR LED locks on or continues to flash for more than 30 seconds after power-up or reset.

- Within 30 seconds, the “LS” (Link Status) LED on the modem should stay on solid indicating that the modem has established communication with the telephone central office.
- The NCB modules are ready for use once the modem “LS” LEDs have come on solid and the NCB “ERR” LEDs have stopped flashing.



# 1. INTRODUCTION

## WHAT IS AN NCB/IS UNIT?

The Network Combiner NCB/IS™ Module is a wide-area router with one or two external ISDN interfaces used for LONWORKS® networks. The NCB/IS unit is used in pairs to connect LONWORKS® networks real-time, spanning distances from building-wide to worldwide. The communication channel spanning the distance between local networks can be any BRI (Basic Rate Interface) ISDN channel. Data transfer between distant networks via an NCB module pair is "live", delayed only by the transit time through the routers and modem connections.

The NCB module uses router technology so that no custom coding or additional hardware is necessary to seamlessly connect multiple networks across very large distances. The NCB module is self-contained, easily configured with standard network management tools, and requires no custom programming or coding changes in system nodes.

The NCB/IS unit contains LONMARK® 3.2 Modem Controller (5091) and Telephone Directory (5092) objects.

### Basic Application

A basic application of the NCB module is where two multi-node LonWorks networks, separated by a distance beyond the reach of conventional wired media, need to be interconnected, as in Figure 1. This distance could be across a large building, business campus, city, etc. Using the NCB module, this interconnection is accomplished using one NCB module local to each network site and a single voice-grade telephone circuit connecting the two NCB modules. Additional networks can be added to this unified network by simply adding an NCB module pair per network.

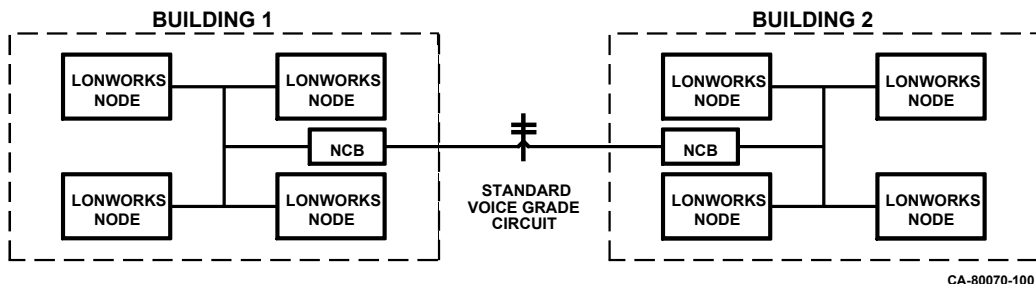

Figure 1 Networks in two buildings connected with NCB modules

### LONWORKS Network Transceivers

The local LonWorks networks at different sites do not need to use the same network transceiver type. For example, an FTT-10A network, a TPT/XF-78 network, and a PLT-22 network can all be interconnected by using pairs of NCB modules with network transceivers matching the local network at each site.

Read this section to learn the general function and capabilities of an NCB Router

NCB units are available with an option for LONWORKS network transceiver type. The ordering code on the rear of the NCB lists the installed options. This ordering code is of the form: **NCB/IS-Txxx-xx**, where 'T' indicates the transceiver type.

The following LONWORKS network transceiver options are available:

A = FTT-10A	K = SMX RS485
B = TPT/XF-78	M = SMX PL22
C = TPT/XF-1250	X = None (SMX ready)

### Wide Area Network Ports

Normally Point-to-Point connections are made between pairs of NCB Units. A more fault-tolerant network may be implemented by using the Ring Mode connection topology.

See Appendix H for Ring Mode details.

### External Serial Ports

"PORT 1" and "PORT 2" are standard asynchronous serial ports with individually configurable baud rates from 1200 to 115200 bps. An external modem can be connected to each port. "PORT 1" and "PORT 2" pinouts allow direct connection to a modem via a standard 9 pin to 25 pin cable.

### Data Flow

There are three sources of message packets within the NCB module. The first source is the LONWORKS NETWORK connector on the front of the unit. The second is the "PORT" connectors on the rear of the unit. The third source is the Control Neuron® Processor. Message packets originating from any of these sources are sent to the other two. This message packet flow is shown in the block diagram of Figure 2.

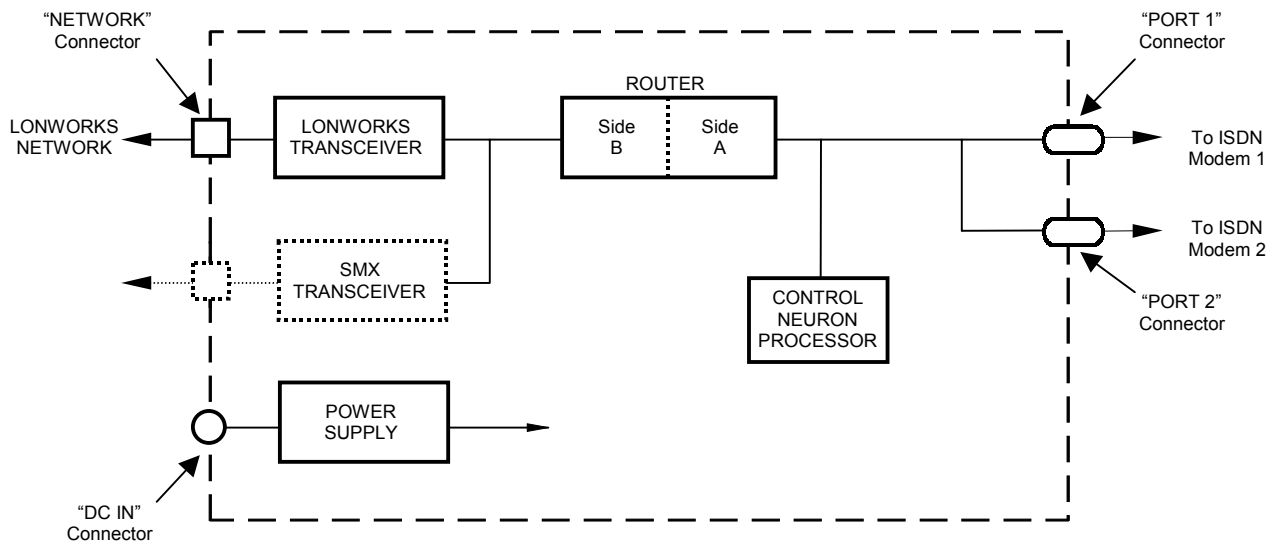

**Figure 2 NCB Network Combiner Block Diagram**

- The "NETWORK" connector attaches to the local LONWORKS network using a compatible transceiver internal to the NCB module and is associated with *Side B* of the internal router.
- The "PORT" connector attaches to the ISDN modem as the link to the NCB unit at the other network site and is associated with *Side A* of the internal router.
- The Control Neuron® Processor allows network management messages to be sent to the NCB module for connection control and status monitoring and is associated with *Side A* of the internal router.

## Router Function

The router contained in each NCB module may be configured as a repeater, bridge, or configured router. The easiest configuration is as a repeater, where all messages which enter the NCB module (via any of the three data sources described above) are simply passed to the other two sources, regardless of the domain, subnet/node, or group destination address. A bridge only passes messages that match one of the two domain IDs configured on the router. A configured router only passes messages that match a domain ID as well as a set of subnet or group numbers. The proper choice of router mode depends on desired simplicity of installation versus required system performance.

---

## REFERENCE DOCUMENTS

The following additional information is available from the sources indicated.

Document	Source	Reference Number
Message Buffer Configuration	CD ROM or <a href="http://www.ctiproducts.com">www.ctiproducts.com</a>	Technical Note TN010
Using Explicit Messages to Configure and Monitor Dialing Parameters of an NCB	CD ROM or <a href="http://www.ctiproducts.com">www.ctiproducts.com</a>	Technical Note TN022
Using NCBCON to Configure and Monitor Dialing Parameters of an NCB	CD ROM or <a href="http://www.ctiproducts.com">www.ctiproducts.com</a>	Technical Note TN023
Setting the PCNSS Card to Network Interface Mode	CD ROM or <a href="http://www.ctiproducts.com">www.ctiproducts.com</a>	Technical Note TN024
SMX Transceiver Installation	CD ROM or <a href="http://www.ctiproducts.com">www.ctiproducts.com</a>	Technical Note TN025
NCB Installation with Network Management Tools	CD ROM or <a href="http://www.ctiproducts.com">www.ctiproducts.com</a>	Technical Note TN026
Introduction to ISDN	CD ROM or <a href="http://www.ctiproducts.com">www.ctiproducts.com</a>	Technology Tutorial TT002
LONWORKS Router User's Guide	Echelon	078-0018-01B

## FRONT PANEL

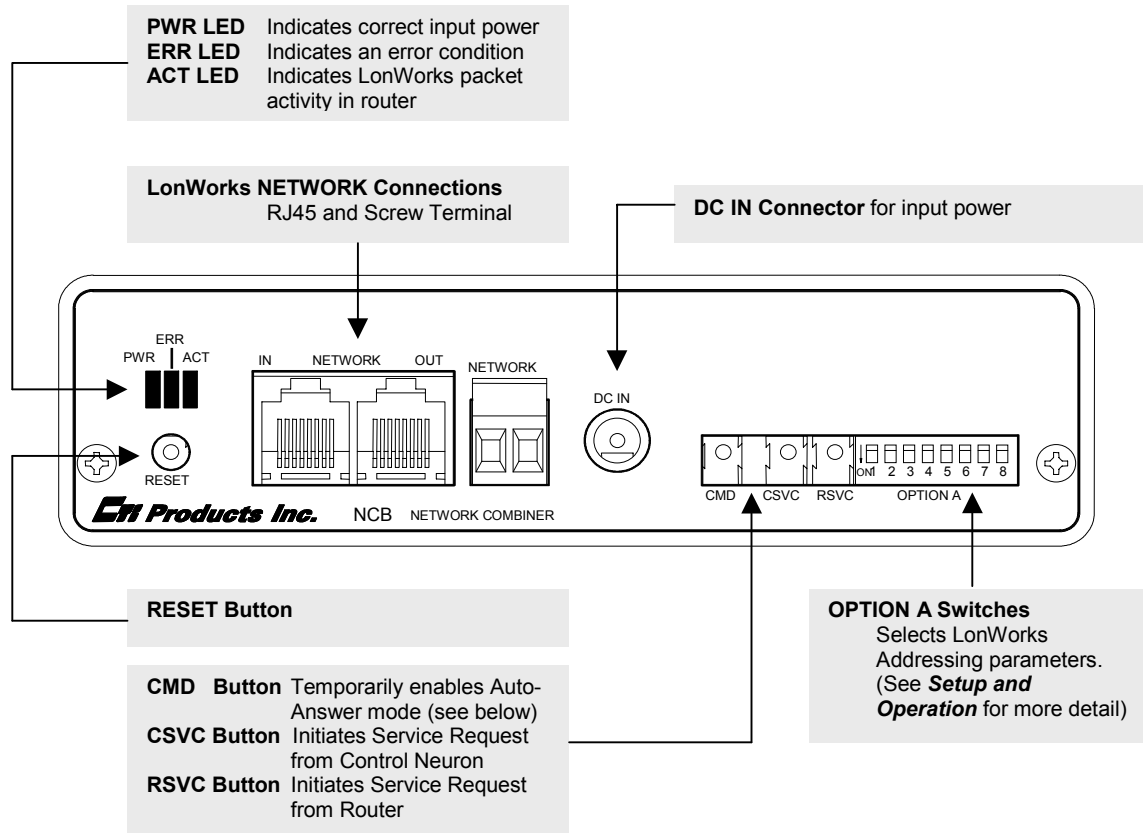

*Figure 3 NCB Front Panel*

### Front Panel Indicators and Buttons

**PWR LED (Green)** - Indicates condition of DC input power or a “Wink” command.

- **Always On:** Correct DC input power is present.
- **Flashing Continuously:** DC input to module is below minimum required voltage.
- **Flashes for 2 Seconds:** A “Wink” network management command has been sent to the Control Neuron Processor.

**ERR LED (Red)** – Indicates a possible error condition.

- **Always On:** A diagnostic error has been detected. Press the “RESET” button. If the “ERR” LED now stays off, the EEPROM contained invalid data and has been reinitialized. Any non-volatile information must be re-entered by using the NCB/Plug plug-in or the DOS NCBCON program. If the LED stays on solid, a hardware problem is indicated. Contact technical support for assistance.
- **Slow Flash:** (once per second) LONWORKS configuration information is insufficient. Using a Network Management Tool, re-commission the internal router nodes (and optionally, the Control Neuron Processor node).
- **Quick Flash:** (twice per second) A serial port configured for use (“BAUD” switch set to a value that is not ‘0’) does not detect an attached modem or is in the process of initializing it. In Ring Mode, this could also indicate that duplicate Unit Numbers have been detected in the Ring.

**ACT LED (Yellow)** - Indicates a packet has been passed by the NCB router.

## CMD Button

This button can be used to temporarily enable the Auto Answer function in Dial-up mode. This is useful if Auto Answer mode has been inadvertently disabled on a remote NCB. When this occurs, and a connection with this remote unit is broken, it will no longer automatically answer an incoming call. To re-enable Auto Answer mode, proceed as follows:

- Press and hold the “CMD” button on the remote NCB
- Press and release the “RESET” button on the remote NCB.
- Wait until the “PWR” LED begins to flash on the remote NCB, then release the “CMD” button.

These steps will temporarily enable Auto Answer mode for the remote NCB for one incoming call. Use NCB/Plug, NCBCON, or explicit messages to re-enable Auto Answer mode for future connections.

## REAR PANEL

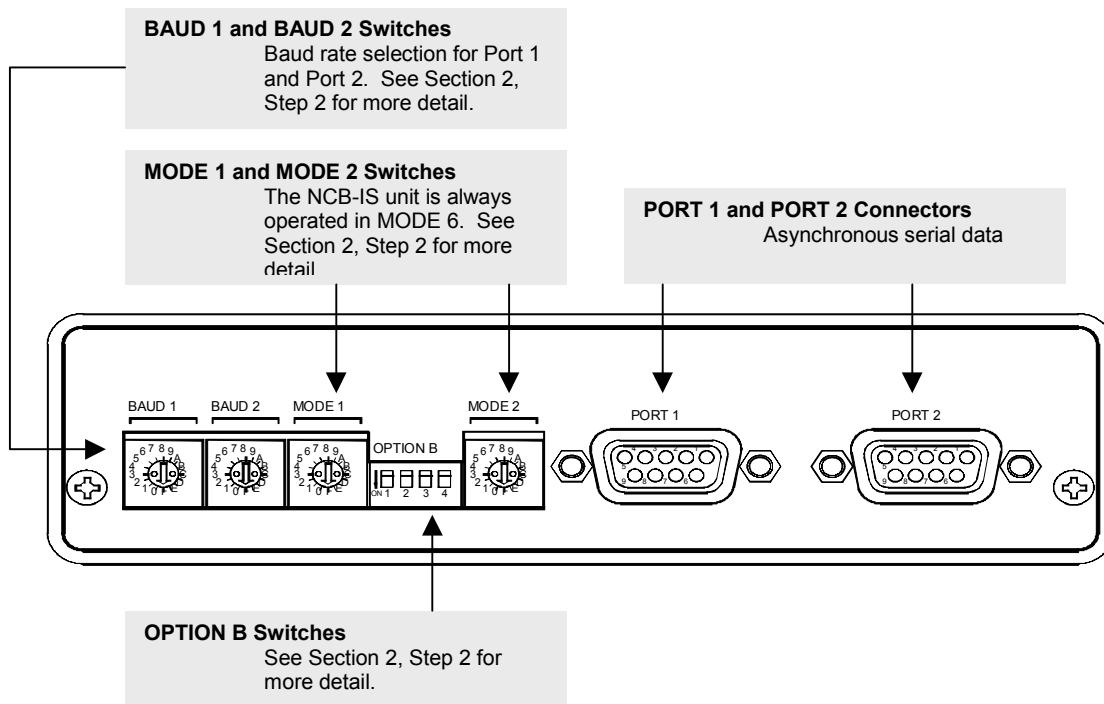

*Figure 4 NCB Rear Panel*



# 2. SETUP AND OPERATION

## STEP 1. MOUNTING

Non-slip rubber feet are included on all NCB modules to allow them to conveniently rest on any horizontal surface. Four 6-32 threaded holes are also available on the bottom of the module to allow bolting of the module in any convenient orientation. **WARNING: Care should be taken to limit protrusion of the screw into the module to no more than 0.125 inch from the module bottom surface!**

Follow the steps in this section to setup an NCB Router for the first time

Mounting kits are available as options to allow wall or rack (19" EIA) mounting of the NCB module.

See Appendix B for Mounting Option details.

When wall or rack mounting the NCB, a suitable safety and protective earth ground should be provided to the metal enclosure. The protective earth ground provides a path to ground for electrostatic discharge (ESD) energy. This connection is most conveniently made directly to the wall mount bracket or rack plate.

## STEP 2. SWITCH SETUP

### OPTION A Switches

OPTION A switches set the **LONWORKS addressing** parameters (switches 5 and 6). Leave the unused switches in the **UP** position. The position of the OPTION A switches are read by the NCB at module power-up or after pressing the "RESET" button on the front panel.

1. Not Used		
2. Not Used		
3. Not Used		
4. Not Used		
5. Control Neuron Addressing Method.....	<b>UP</b>	<b>DOWN</b>
6. Control Neuron Hardware Subnet/Node	Hardware 255/2	Network Management Tool 255/1
7. Not Used		
8. Not Used		

### Setting the LONWORKS Addressing Parameters (Switches 5 and 6)

Switches 5 and 6 provide a simple (but very limited) method of setting the LONWORKS domain/subnet/node address of the internal Control Neuron Processor. This method is useful for systems with two NCB modules, but does not provide enough flexibility for larger systems. (Standard Network Management Tools are a much better choice.) For more information on setting this address, see "STEP 5. IMPLEMENTATION IN A NETWORK" for a tutorial on network management tools.

- If OPTION A Switch 5 is **UP**, Switch 6 determines a static subnet/node address for the Control Neuron Processor: Switch 6 **DOWN** fixes the Control Neuron Processor subnet/node address at 255/1 in the zero-length domain, while Switch 6 **UP** fixes the subnet/node address at 255/2 in the zero-length domain. This setting allows for a quick evaluation of the NCB modules, requiring minimal user setup.
- If OPTION A Switch 5 is **DOWN**, dynamic determination of the domain/subnet/node number by a Network Management Tool is allowed.

### OPTION B Switches

OPTION B switches set the *Serial Port Handshaking* options.

	<b>DOWN</b>	<b>UP</b>
1. PORT 1 Auto Answer Mode .....	Disabled	Enabled (Normal)
2. PORT 1 DSR sense .....	Disabled	Enabled (Normal)
3. PORT 2 Auto Answer Mode .....	Disabled	Enabled (Normal)
4. PORT 2 DSR sense .....	Disabled	Enabled (Normal)

DSR/DTR handshaking informs the NCB that a connected device is active. If the channel does not directly support DSR/DTR handshaking, DSR must be strapped back to the (always active) DTR output signal.

When enabled, the operation of DSR/DTR is as follows:

Signal	Direction	Function
DSR	Input to NCB	Active when a connected device is functioning. This signal is driven by the DTR signal of the connected device. If driven inactive, NCB front panel "ERR" LED will flash quickly, and NCB will not communicate with this device. If DSR signal is not available from connected device, strap to DTR output.
DTR	Output from NCB	Always driven active by NCB.

### BAUD Switches

"BAUD 1" and "BAUD 2" switches correspond to "PORT 1" and "PORT 2" connectors and allow either disabling the port for use or enabling it at a specific baud rate.

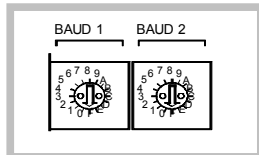

Position	Function/Baud Rate
0	Disable Port
1	1200 Baud
2	2400
3	4800
4	9600
5	19200
6	38400
7	57600
8	115200

**NOTE:** Set the "BAUDn" switch to 0 if the respective port will not be used. This is important, as the front panel "ERR" LED will flash continuously if a serial port "BAUD" switch is non-zero and no modem is connected.

**NOTE:** The baud rate must be set to 115200 in order for the ISDN modem to connect at the full 64 Kbps rate.

### Mode Switches

“MODE 1” and “MODE 2” switches allow setting the NCB for compatibility with certain types of external modems. A different type of modem can be connected to each port. **NOTE:** previous versions of the NCB unit have only one “MODE” switch. In this case, two modems can still be connected to a single NCB unit, but they must both be of the same type.

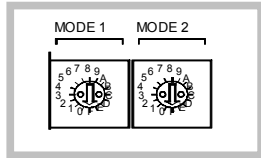

Set both “MODE” switches to 6 for proper operation of the NCB-IS.

## STEP 3. ELECTRICAL CONNECTIONS

### LONWORKS Network Connection

The local LONWORKS network must be attached to the NCB module via the “NETWORK” connector following standard Echelon guidelines as to cable type, cable length, and termination appropriate for the selected transceiver.

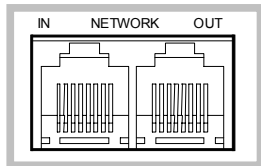

The dual RJ45 “NETWORK” connector allows a daisy-chained network connection method, as the network pins of the two RJ45 connector are directly paralleled. Note that other pins on the RJ45 are connected to circuit ground and DC power.

See Appendix C for Connector Details

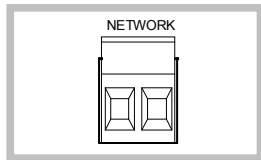

The 2 pin removable terminal strip is wired in parallel with the network connections on the dual RJ45 connector.

**NOTE:** If your NCB module was purchased without a LONWORKS transceiver (SMX-ready), refer to Technical Note TN025 to install your SMX transceiver.

### Modem Connection

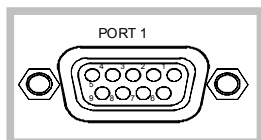

Connect the ISDN modem(s) to “PORT 1” (and “PORT 2” if two modems are being used) on the rear of the NCB unit using the cable(s) supplied with the modem(s) (this is a standard 9 pin to 25 pin modem cable). Attach the telephone line and provide power to the external adapter(s) per the manufacturer requirements.

See Appendix C for pinouts and cable diagrams.

**NOTE:** Set the **BAUD 1**, **BAUD 2**, **MODE 1**, **MODE 2**, and **OPTION B** switches according to information in section “2. SETUP AND OPERATION”, “STEP 2. SWITCH SETUP” **BEFORE** powering up the NCB module.

### **DC Power Connection**

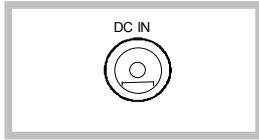

DC power must be attached to the NCB module via the **DC IN** connector (see “APPENDIX C. CONNECTOR DETAILS”). **Apply DC power to the NCB module only after all other connections have been made.** A wall plug-in style power supply designed for the NCB module is an available option.

---

## **STEP 4. MODEM CONFIGURATION**

### **European Community**

First, determine the “Network Switch Type” that this ISDN modem will be connected to. This information is provided by the telephone service company when the ISDN line is installed.

If the switch type at the telephone company’s central office is ‘EuroISDN’ (also designated “ETSI” or “NET3”), and the ISDN modem used is Multitech model MTA128ST, no configuration of the ISDN modem is needed. If this is the case, proceed to “STEP 5. IMPLEMENTATION IN A NETWORK”.

### **North America and Others**

Configuration for all other instances of the ISDN modem must be performed before it can communicate with the NCB module. This configuration process is only required once (when the ISDN modem is first configured for use with the NCB) and uses software provided with the ISDN modem. The following information (provided by the installer of the ISDN phone lines to which the adapters will be connected) is required to complete this configuration:

- Network Switch Type, i.e. 5ESS, NI-1, DMS-100, INS64, ETSI/NET3, 1TR6, VN4
- The Data and Voice Terminal Endpoint Identifiers (TEI). If none are given, these can be automatically set.
- The Data and Voice “Directory Numbers” (DNs)
- Service Profile Identifiers (SPIDs), if used in North America or Japan

More details about ISDN can be found in Technical Tutorial TT002 “Introduction to ISDN”.

When the above information is known, configuration of the ISDN modem can take place. Connect the ISDN modem to an available COM port on the PC, power-up the ISDN modem, and install and start the configuration utility software that was provided with the ISDN modem. Specific details for running configuration utilities for Multitech’s MTA128 (“ISDN TA Configuration Utility”) and U.S. Robotics Courier-I (“I Modem Configuration ISDN Program”) can be found in “Appendix G. Modem Notes”.

## STEP 5. IMPLEMENTATION IN A NETWORK

### Will a Network Management Tool Be Used?



- If NO, and the NCB will be used with its factory default settings (Repeater Mode), skip the rest of this section. The NCB is ready to function in a network.
- If NO, and the DOS NCBCON program will be used to access and configure the Control Neuron Processor, then see Technical Note TN023.
- If YES, and LonMaker For Windows will be used, **be certain that 'OPTION A Switch 5 is in the DOWN position**, and see Commissioning the NCB with LonMaker for Windows later in this section.
- If YES, and another Network Management Tool will be used, **be certain that 'OPTION A Switch 5 is in the DOWN position**, then see Technical Note TN026.

## Tutorial . . .

### Why is a Network Management Tool needed?

#### Factory Default Settings

An NCB could be placed in a network using the configuration as it was shipped from the factory (Repeater Mode, fixed Subnet/Node address). All messages would simply be passed through the NCB. This may suffice for small networks where channel bandwidth and message timing issues are of no concern.

#### Use of a Network Management Tool

If a larger network is planned, and channel bandwidth limitations require segmentation of message traffic, then a Network Management Tool should be used to perform some or all of the following functions:

- Assign unique addresses to each NCB Router and Control Neuron
- Configure domain address tables in routers
- Optimally set Transaction Timers based on Channel Delays
- Configure forwarding tables in routers for traffic segmentation

### Commissioning the NCB with LonMaker for Windows

Commissioning *each* NCB *in a network* with LonMaker for Windows involves commissioning two different network devices, both contained in the single NCB enclosure: a standard LONWORKS *router*, and the *control neuron*.

Since the standard LONWORKS router portion of an NCB router interfaces a LONWORKS channel to a Telephone (WAN) channel, it requires connection to two channels on the LonMaker drawing. A standard LONWORKS channel will be connected to *Side B* of the router shape, and a **CUSTOM** (Telephone, WAN) Channel will be connected to *Side A* of the router shape.

### Installing NCB/Plug Plug-in

- A) Install the NCB/Plug plug-in on your PC:
- Insert the NCB/Plug CD into your CD-ROM drive.
  - Click the Windows Start button, choose Run..., click **Browse...**, select the Setup application on the NCB/Plug CD, and click **Open**.
  - Follow the instructions displayed by the Setup application.
  - Restart your computer when the Setup application is complete.

**NOTE:** Two External Interface Files (.XIF) are automatically transferred to the hard drive when NCB/Plug plug-in is installed. *NCBTLC30.XIF* should be used for the Control Neuron Processor of an NCB of Version 3. *NCBTLC20.XIF* should be used for the Control Neuron Processor of an NCB of Version 2.

- B) Register NCBPlug with LonMaker for Windows:
- Click the Windows Start button, choose Programs, then NCBPlug, and click on NCBPlug.
  - Click **Register Plug-In**.
  - Click **Exit**.
- C) Register NCB/Plug with the desired LonMaker for Windows network:
- Start LonMaker for Windows and open the desired network (be sure to checkmark the “Show all Network Option Screens” box). When the “Plugin Registration” window within the Network Wizard appears, highlight the “NCB\_Plug” under “To Be Registered” and click Finish.

After installing and registering the NCB/Plug plugin, commission *the “local NCB” (the one whose “NETWORK” port is connected to the NSI attached to LonMaker for Windows)* using the following steps:

### Commissioning the NCB

- A) Add a CUSTOM channel to the network drawing (this will be the WAN channel):
- Drag the **Channel** shape to the drawing. The “*Channel Definition*” window will be displayed.
  - Specify an appropriate Channel Name.
  - In the “Transceiver Type” field, click the down arrow and select **CUSTOM**.
  - In the “Delay” section, choose “Specify”, and enter a value of 85ms.
  - Enter a Channel Description, if desired.
  - Click **OK** to continue.
- B) Add the standard LONWORKS router portion of the NCB to the network drawing:
- Drag the **Router** shape to the drawing. The “*New Router Wizard*” window will be displayed.
  - Specify the desired router name.
  - Click **NEXT** to continue.
  - In the “Channel A” **Name** field, choose the custom channel created in *Step a*.
  - In the “Channel B” **Name** field, choose the standard LONWORKS channel connected to the “NETWORK” connector on the NCB.
  - Click **NEXT** to continue.
  - Specify a Location string and Description, if desired. “Ping Interval” can be set as desired, however should be set to “never” for remote NCB routers which are not connected full-time (for example, those connected via dial-up telephone lines).
  - Click **NEXT** to continue.
  - Specify desired advanced router properties. *Router Type : Configured* is recommended.
  - Click **FINISH** to complete the “*New Router Wizard*”.
- C) Add the Control Neuron Processor to the network drawing:
- Drag the **Device** shape to the drawing. The “*New Device Wizard*” window will be displayed.
  - Specify the desired Device Name.
  - Click **NEXT** to continue.
  - In the “External Interface Definition” section, choose ‘Existing Template’, click the down arrow and choose the appropriate template as follows: *NCBTLC30.XIF* should be used for the Control

Neuron Processor of an NCB of Version 3, NCBTLC20.XIF should be used for the Control Neuron Processor of an NCB of Version 2.

- Click **NEXT** to continue.
  - In the “Channel: Name:” section, choose the custom channel connected to *Side A* of the router that was created in *Step a*.
  - Click **NEXT** to continue
  - Specify a Location string and Description, if desired. “Ping Interval” can be set as desired, however should be set to “never” for remote NCBs which are not connected full-time (for example, those connected via dial-up telephone lines).
  - Click **FINISH** to complete the “*New Device Wizard*”.
- D) Commission the LONWORKS router:
- Right-click on the router shape added in *step b*.
  - Click on the *Commission* function
  - Select the *Online* state.
  - Click **FINISH** to commission the router.
- E) Commission the Control Neuron:
- Right-click on the Control Neuron device shape added in *step c*.
  - Click on the *Commission* function
  - Select the *Online* state and *Current Values in Database* for *Source of Configuration Property Values*.
  - Click **FINISH** to commission the Control Neuron.

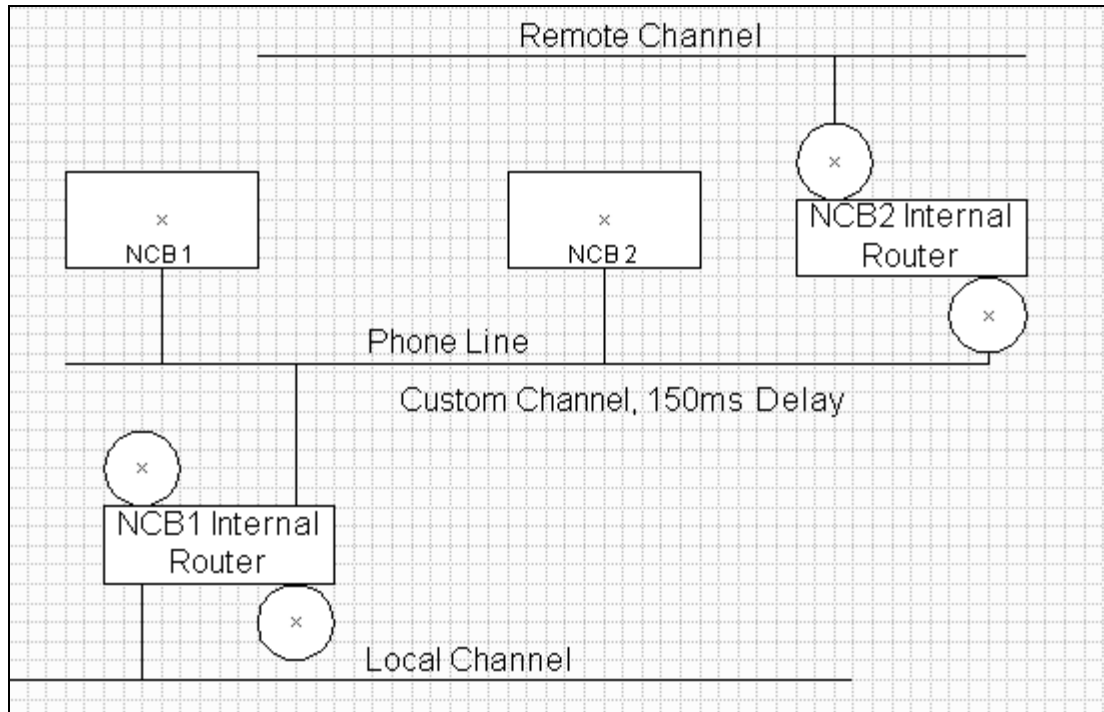

Figure 5--LonMaker NCB Diagram

## STEP 6. CONTROLLING THE WAN CONNECTION

At this point, the “local” NCB (the one connected to the LonMaker for Windows NSI) has been configured and fully commissioned for use. This last step involves making a connection to the “remote” NCB via the Telephone (WAN) channel.

The local NCB must be commanded to dial into the remote NCB in order to commission it. The simplest way to command this dialing to occur is to use the NCB/Plug plugin. Alternatively, the Network Variable interface can be used. See the following tutorial. Once the connection is established with the remote NCB, message packets will flow between them. To commission the remote NCB router and control neuron, repeat *B* through *E* of [Commissioning the Router](#) in *Step 5* above.

### Network Variables and the NCB/Plug Plug-In

#### Tutorial . . .

##### Network Variables

Network Variable Bindings allow a device to send and receive messages to and from other devices on the network. All configuration and status commands sent to the NCB module are carried on the LonTalk network in the form of Network Variables bound to the Control Neuron Processor inside the NCB module. The following functions are available if Network Variable bindings are made:

- Send a dial string to a modem
- Send a ‘Call Cancel’ command to a modem
- Request ‘Connect Status’ from a modem
- Request a ‘Connect String’ output from a modem
- Select Dial Mode (Manual Dial or Perpetual Connect)
- Select Auto Answer Enabled Mode
- Configure Ring Mode parameters
- Request a soft reboot of NCB
- Request Product Name Output from NCB

*Will bindings be made to any Network Variables?*

?

- If NO, you may wish to use the NCB/Plug Plug-In (See ‘**Tutorial: NCB/Plug**’ above).
- If YES, see SECTION 3, [NETWORK VARIABLE \(NV\) CONTROL](#). You may also wish to use the NCB/Plug plug-in (See ‘**Tutorial: NCB/Plug**’ above).

#### Tutorial . . .

##### NCB/Plug

LNS plug-ins are applications that can be started from within an LNS application (such as the LonMaker tool) to perform a specialized task. The NCB/Plug plug-In implements configuration and query commands for the NCB. The NCB/Plug plug-In and Network Variables can be used simultaneously. The following functions are available if the NCB/Plug plug-In is installed:

- Send a dial string to a modem
- Send a ‘Call Cancel’ command to a modem
- Configure the NCB Telephone Directory
- A window displays ‘Connect Status’
- Select Dial Mode (Manual Dial or Perpetual Connect)
- Select Auto Answer Enabled Mode
- Configure Ring Mode parameters
- Request a soft reboot of NCB

*Will NCB/Plug be used?*

?

- If NO, you may wish to make Network Variable bindings (See ‘**Tutorial: Network Variables**’ above).
- If YES, see SECTION 4, [NCB/PLUG](#). You may also wish to make Network Variable bindings (See ‘**Tutorial: Network Variables**’ above).

## 3. NETWORK VARIABLE (NV) CONTROL

### TYPICAL NV BINDINGS

All commands sent to the NCB module are carried on the LonTalk network in the form of Network Variables bound to the Control Neuron processor inside the NCB module (connected to *Side A* of the internal router). This section details the **Functional Blocks** (objects) and the network variables of each. The Modem Controller Objects and Directory Objects will be functional only if a modem is attached to the “PORT” connector.

This Section contains details of Network Variables and Bindings

The Internal and external Modem Controller Objects meet the LONMARK<sup>®</sup> 3.2 “Modem Controller” Functional Profile #5091. In addition, two Directory Objects are included which meet the LONMARK<sup>®</sup> 3.2 “Directory” Functional Profile #5092. Finally, a Global Object is included to help perform miscellaneous tasks.

The Modem Controller Object is typically used in conjunction with the Directory Object and some other event-generating object which causes connection control information to be given to the Modem Controller Object. This information initiates modem dialing so that, once a connection is established, transfer of data can be accomplished via the modem.

Figure 6 is an example of typical network variable bindings.

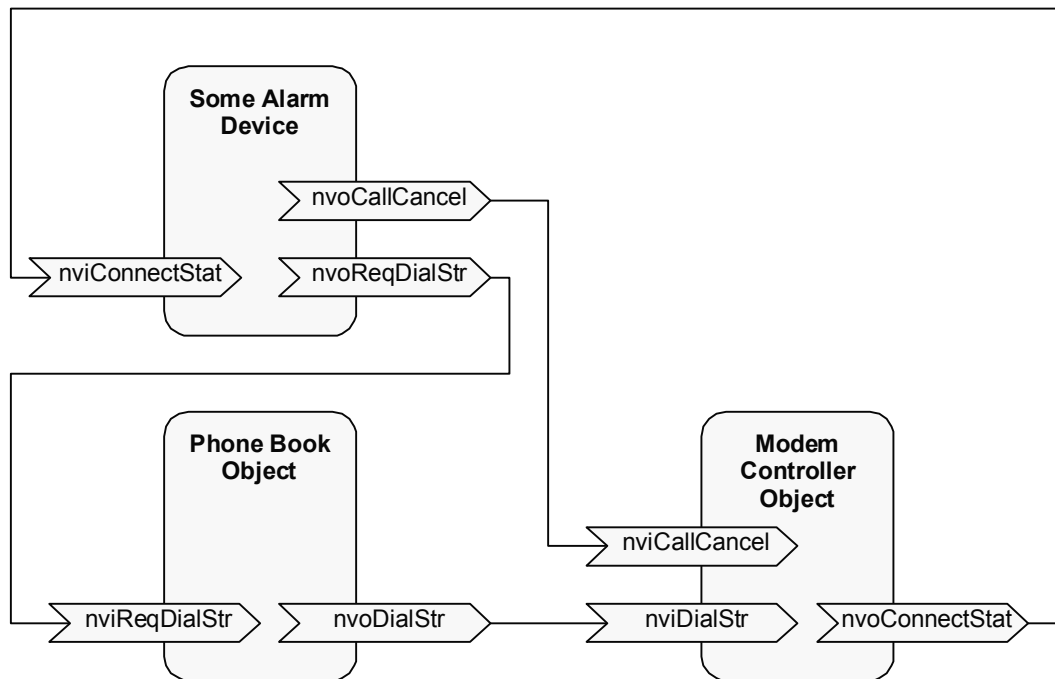
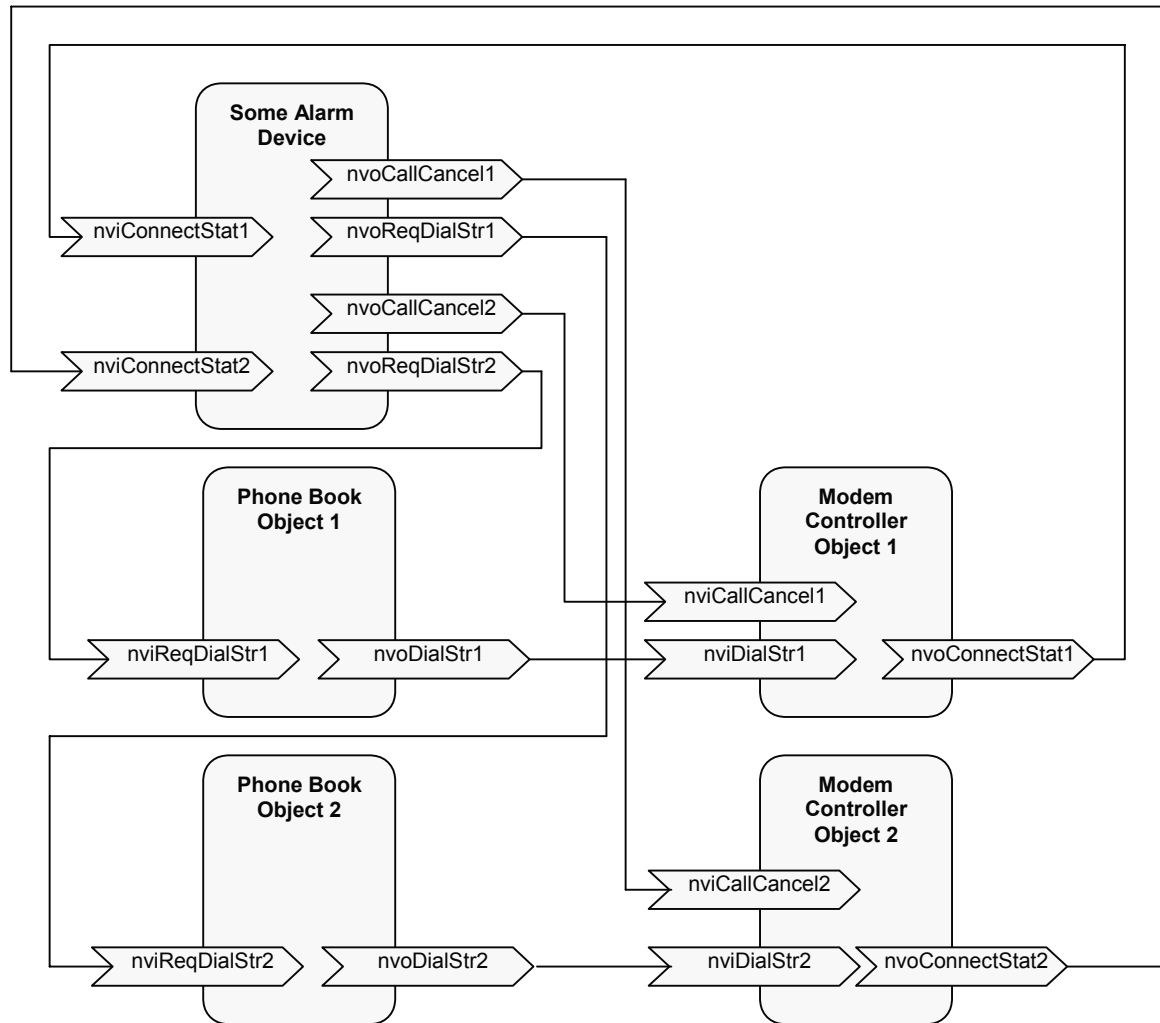

Figure 6 Typical Network Variable Bindings

The example in Figure 7 uses multiple Directory Objects with multiple Modem Controller Objects.



*Figure 7 Multiple Directory Objects with Multiple Modem Controller Objects*

## MODEM CONTROLLER OBJECT

The Modem Controller Object is used to control the functions of the NCB Module's data modem. These functions include configuration, connection control, and connection status. Three Modem Controller Objects are available, depending on the NCB model being used. 'Internal Modem' is for use with the NCB-IM. 'External Modem1' and 'External Modem 2' are for use with the NCB-EM and NCB-IS. All three Modem Controller Objects have identical network variable inputs and outputs.

## Network Variables

### Dial String (Input)

#### C Language Syntax

```
network input SNVT_str_asc nviDialStr1;
network input SNVT_str_asc nviDialStr2;
```

#### Usage

- A non-null string sent to this input network variable while the current modem connection state is TEL\_NOTINUSE causes the modem to go off hook, wait for a dial tone, then perform a dialing sequence using the provided character string.
- A non-null string sent to this input network variable while the current modem connection state is other than TEL\_NOTINUSE has no effect on the modem connection state or action.
- A null string sent to this input regardless of current modem connection state has no effect on the modem connection state or action.

#### Valid Range

- A NULL terminated ASCII string up to 31 bytes in length.
- All ASCII characters are valid, with specific support for the following:
  - Letter P (upper or lower case, first character in string only) – Pulse Dial.
  - Digits (0-9,\*,#) – Dials digit directly.
  - Comma (,) – Pauses 2 seconds for each comma encountered.
  - Letter W (upper or lower case) – Pauses until a dial tone is detected.
  - Exclamation Point (!) – Hookflash, go on hook for 0.5 seconds, then back off hook.
  - Punctuation (space, dash, left and right parentheses) – Valid in string, but ignored.

### Call Cancel (Input)

#### C Language Syntax

```
network input SNVT_switch nviCallCancel1;
network input SNVT_switch nviCallCancel2;
```

#### Usage

- An input value of *ON* to this network variable causes the modem to immediately go on hook, terminating the connection attempt in progress or breaking the existing connection to the distant modem. The modem returns to the TEL\_NOTINUSE state.

#### Valid Range

Value	Call Cancel
Off	No Action
On	Modem goes On-Hook

#### Default Value

Off

### Connect Status (Output)

#### C Language Syntax

```
network output SNVT_telcom nvoCnctStat1;
network output SNVT_telcom nvoCnctStat2;
```

#### Usage

- This output network variable provides the current state of the modem connection process.

#### Valid Range

Value	Output String	Description
0	TEL_NOTINUSE	Modem on hook and idle
1	TEL_OFFHOOK	Modem waiting for dial tone
2	TEL_DIALING	Modem dialing (and training for NCB/EM)
3	TEL_DIALCOMP	Modem executing mid dial pause (NCB/IM only)
7	TEL_ANSWERED	Modem training (NCB/IM only)
9	TEL_TALKING	Modem connected and online with distant modem, ready to send data
12	TEL_HOLD	Modem retraining (NCB/IM only)
20	TEL_ERROR	Modem initializing, not present, or port disabled

#### When Transmitted

The output is updated upon each change in modem connection state.

#### Update Rate

The output is updated only once per change in modem connection state.

### Connect String (Output)

#### C Language Syntax

```
network output SNVT_str_asc nvoCnctStr1;
network output SNVT_str_asc nvoCnctStr2;
```

#### Usage

- This output network variable provides detail in text format of the connection parameters established after the modem connection has reached the TEL\_TALKING state. These parameters include connect speed, protocol, error correction, etc.

#### Valid Range

A NULL terminated ASCII string up to 31 bytes in length.

#### When Transmitted

The output is updated when the modem connection state reaches TEL\_TALKING or TEL\_NOTINUSE.

#### Update Rate

This network variable is updated once after the modem has entered the TEL\_TALKING state and once after the modem has entered the TEL\_NOTINUSE state.

### Request Dial String (Output)

#### C Language Syntax

```
network output SNVT_char_ascii nvoReqDialStr1;
network output SNVT_char_ascii nvoReqDialStr2;
```

#### Usage

- This output network variable is associated with *Perpetual Dial-Up Mode* (see Tutorial “Which Modem Mode Should Be Used” in section “2. SETUP AND OPERATION”) and is used

when the Directory Object storing the telephone number (to be dialed) belongs to *a node other than the call-originating NCB*.

**Valid Range**

0-F (Hex)

**When Transmitted**

Transmitted when the Modem Controller Object senses that a connection is not made.

**Perpetual Dial-up Mode**

The NCB module can be configured to provide a “perpetual” connection *using the ‘dial-up’ mode of the modem*, with no runtime user or application intervention required to initiate or maintain a constant modem connection.

There are two methods available for implementing a “perpetual” connection using Dial-up mode:

- 1) The first method uses only configuration properties. This method is useful when the Directory Object storing the telephone number (to be dialed) belongs to the dialing NCB module.
  - a) Specify an entry in an NCB Units Directory that contains the phone number to be dialed. This can be accomplished using either the NCB/Plug plug-in (discussed in “Section 4. NCB/Plug” or using the “Dial Mode” Configuration Property (discussed later in this section).
  - b) Set the “Dial Mode” (for the call-originating NCB) to “*Perpetual*”. This can be accomplished most easily with the NCB/Plug plug-in (discussed in “Section “4. NCB/Plug” by accessing *Dial Mode* choices under the *Modem Options* menu item. Changing the Dial Mode to *Perpetual* may also be accomplished by using the “Dial Mode” Configuration Property (discussed later in this section).
- 2) The second method uses a combination of configuration properties and network variable bindings. This method is useful when the Directory Object storing the telephone number (to be dialed) belongs to a *node other than the call-originating NCB*.
  - a) Specify an entry in an NCB Units Directory that contains the phone number to be dialed. This can be accomplished using either the NCB/Plug plug-in (discussed in “Section 4. NCB/Plug” or using the “Dial Mode” Configuration Property (discussed later in this section). This step is the same as in the first method.
  - b) Set the “Dial Mode” to “Manual” mode (the default setting).
  - c) Make network variable bindings as shown in Figure 8.

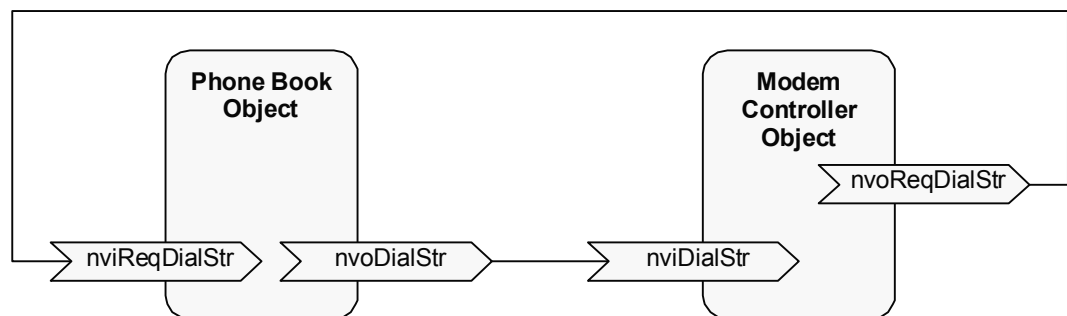

**Figure 8 Perpetual Dial-up Mode using NV Bindings**

## Configuration Properties

### Will Configuration Properties be modified?



- If NO, and the NCB objects (functional blocks) will be used with factory default settings (Manual *Dial-Up* or *Leased-Line* modes, Auto Answer mode Enabled, Ring Mode disabled), skip to Directory Object, later in this section.
- If YES, but the NCB/Plug plug-in will be used to modify the Configuration Properties, skip to Directory Object, later in this sections and also section "4. NCB/PLUG".
- If YES, then the information following in this section will be useful.

## Tutorial . . .

### Why are Configuration Properties important?

Configuration Properties of an object (such as the Telephone Directory Object or Modem Controller Object) are used to alter the operation of a device. These properties are normally setup parameters that are accessed just once for purposes of initialization. However, they may be altered at any subsequent time.

Configuration Properties may need to be changed from default values if any of the following is required:

- Perpetual Connect mode enabled (in Modem Controller Object).
- Auto Answer mode disabled (in Modem Controller Object).
- Dial string entry (in Telephone Directory Object),
- Ring Mode enabled and parameters initialized (in Global Control Object).

### Accessing Configuration Properties

Alternative methods of accessing Configuration Properties are available:

- Direct access by either Network Variable bindings or File Transfer (if a large amount of data is involved).
- Indirect access when a plug-in is used, such as the NCB/Plug plug-in.



Value	Auto Answer Mode
Off	Disabled
On	Enabled

**Default State**

On (Enabled)

---

## TELEPHONE DIRECTORY OBJECT

A Telephone Directory Object is used to store and retrieve arrays of ASCII strings that are characterized as telephone numbers (including characters used for control) used in dialing a data modem. The ASCII arrays are configured using data file transfer or configuration network variables and are retrieved in real-time using an index value passed via a network variable.

The output of a Directory Object (which emits telephone numbers) is typically bound to a Modem Controller Object. The input to a Directory Object is typically driven by an object requiring the services of the Modem Controller Object to accomplish some connectivity task, e.g. notification of an alarm to a remote site. Usage of a Directory Object allows the alerting object to initiate dialing of the Modem Controller Object to a specific telephone number by simply emitting an array index from 0 to 15.

Two Directory Objects are available, for independently sending a distinct dial string to each of two Modem Controller Objects. The Directory Objects use the same configuration data (all contain the same dial string data).

***Network Variables*****Request Dial String (Input)****C Language Syntax**

```
network input SNVT_char_ascii nviReqDialStr1;
network input SNVT_char_ascii nviReqDialStr2;
```

**Usage**

Two variables are available, one for each of the Directory Objects. These input network variables request the output of a telephone number, from the requested index.

**Valid Range**

0-15

**Dial String (Output)****C Language Syntax**

```
network output SNVT_str_asc nvoDialStr1;
network output SNVT_str_asc nvoDialStr2;
```

**Usage**

Two variables are available, one for each of the Directory Objects. These output network variables provide the phone number string from the Directory entry corresponding to the index number received on nviReqDialStrx.

**Valid Range**

A NULL terminated ASCII string up to 31 bytes in length (including the NULL).

All ASCII characters are valid, with specific support for the following:

- Letter P (upper or lower case, first character in string only) – Pulse Dial.
- Digits (0-9, \*, #) – Dials digit directly.
- Comma (,) – Pauses 2 seconds for each comma encountered.
- Letter W (upper or lower case) – Pauses until a dial tone is detected.
- Exclamation Point (!) – Hookflash, go on hook for 0.5 seconds, then back off hook.

Punctuation (space, dash, left and right parentheses) – Valid in string, but ignored.

**When Transmitted**

Transmitted upon receipt of a valid nviReqDialStr input, unless requested entry index is not supported or entry is blank (first character of entry is a NULL), in which case this variable is not transmitted.

Receipt of another nviReqDialStr input causes this output to be transmitted, containing the phone number string from the Directory entry corresponding to the index received on nviReqDialStr, even if the index received is the same index as received on the previous update to nviReqDialStr.

**Update Rate**

Updated only on an update to nviReqDialStr input.

## Configuration Properties

### Dial String

**C Language Syntax**

```
network input config SNVT_str_asc nciSetPhoneNum;
```

**Usage**

The first byte (character) specifies the *Index* entry (0-F hex) of the Directory Object. Up to 29 additional bytes (characters) can be used to specify the dial string.

**Valid Range**

A NULL terminated ASCII string up to 31 bytes in length (including the NULL).

All ASCII characters are valid, with specific support for the following:

- Letter P (upper or lower case, first character in string only) – Pulse Dial.
- Digits (0-9,\*,#) – Dials digit directly.
- Comma (,) – Pauses 2 seconds for each comma encountered.
- Letter W (upper or lower case) – Pauses until a dial tone is detected.
- Exclamation Point (!) – Hookflash, go on hook for 0.5 seconds, then back off hook.
- Punctuation (space, dash, left and right parentheses) – Valid in string, but ignored.

**Default Value**

The NULL character.

*The File Transfer method of communications can also be used to configure the Dial String(s) in a Directory Object. A Dial String Array (nciDialStr[16]) can be loaded with the desired dial strings. This array holds data of type SNVT\_str\_asc.*

---

## GLOBAL CONTROL OBJECT

The following network variables pertain to the entire NCB, and not just to a single Modem Controller object or Directory Object.

### Product Name (Output)

**C Language Syntax**

```
network output SNVT_str_asc nvoProductName;
```

**Usage**

This output network variable contains an ASCII string identifying the product.

**When Transmitted**

Unsolicited at power-up and reset, or when polled.

## Ring Status (Output)

### C Language Syntax

```
network output SNVT_switch nvoRingStat;
```

### Usage

This output network variable provides ring *open* or *closed* status. It has no function in the NCB-IM.

### Valid Range

Value	Ring Status
Off	Open
On	Closed

## Configuration Properties

### Ring Mode Parameters

```
typedef struct UCPT_RingMode
{
    unsigned char Enable;
    unsigned char UnitNumber;
    unsigned long PropDelay;
    unsigned long TestInterval;
}
```

### Usage

This output structure contains setup information when a group of NCB Modules are configured in a redundant ring topology. It has no function in the NCB-IM. See “APPENDIX H. RING MODE ” for additional Ring Mode details.

### Valid Range

Enable: 0 (Disabled), 1 (Enabled)

UnitNumber: 0 to 64

PropDelay: 1,000 to 7,500 (ms)

TestInterval: 10,000 to 65,000 (ms)

### When Transmitted

When polled.

## 4. NCB/PLUG CONFIGURATION PLUG-IN

LNS plug-ins are applications that can be started from within an LNS application (such as LonMaker for Windows) to perform a specialized task. The NCB/Plug configuration plug-in implements configuration and query commands for the NCB. The NCB/Plug plug-in and Network Variables can be used simultaneously. The following functions are available if NCB/Plug is installed:

- Pulse router service pin
- Request a soft reboot of NCB

The following function (for models NCB-EM, NCB-IS, and NCB-AY) will also be displayed, but will have no effect when using NCB-IM and NCB-RF models:

- Configure Ring Mode parameters

The following functions (for models NCB-IM, NCB-EM, and NCB-IS) will also be displayed, but will have no effect when using NCB-AY, and NCB-RF models:

- Send a dial string to a modem
- Send a 'Call Cancel' command to a modem
- Configure the NCB Directory
- A window displays 'Connect Status'
- Select Dial Mode (Manual or Perpetual)
- Select Auto Answer Enabled Mode

---

### INSTALLATION

NOTE: If you have already performed these steps as detailed in Section 2 "Setup and Operation", they do NOT need to be repeated here. In this case, skip directly to "Accessing NCB/Plug" below.

1. Install the NCB/Plug plug-in on your PC:
  - a) Insert the NCB/Plug CD into your CD-ROM drive.
  - b) Click the Windows Start button, choose Run..., click **Browse...**, select the Setup application on the NCB/Plug CD, and click **Open**.
  - c) Follow the instructions displayed by the Setup application.
  - d) Restart your computer when the Setup application is complete.
2. Register NCB/Plug with LonMaker for Windows:
  - a) Click the Windows Start button, choose Programs, then NCBPlug, and click on NCBPlug.
  - b) Click **Register Plug-In**.
  - c) Click **Exit**.
3. Register NCB/Plug with the desired LonMaker for Windows network:
  - a) Start LonMaker for Windows and open the desired network (be sure to checkmark the "Show all Network Option Screens" box). When the "Plugin Registration" window within the Network Wizard appears, highlight the "NCB\_Plug" under "To Be Registered" and click Finish.

Two *External Interface Files* (.XIF) are automatically transferred to the hard drive when NCB/Plug plug-in is installed. NCBTLC30.XIF should be used for the Control Neuron Processor of an NCB of Version 3. NCBTLC20.XIF should be used for the Control Neuron Processor of an NCB of Version 2.

## ACCESSING NCB/PLUG

- Bring NCB/Plug to the desktop:
- Right click on the Control Neuron Functional Block to be configured (Modem, Directory, Globals). In the drop-down list, click “Configure”. The Plugin will appear as shown here.
- Alternatively, right click on the Control Neuron Processor device shape. In the drop-down list, click “Plug-Ins...”, and select NCB/Plug. Click **OK** to continue. The Plugin will appear as shown here.

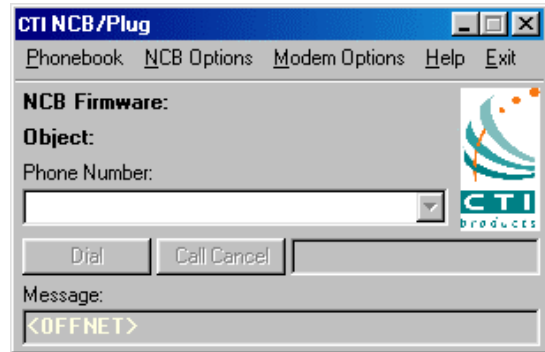

## USAGE

Starting NCB/Plug from a Modem or Global Functional block shows the main NCB/Plug window from which both modem and Directory configurations and operations may be performed. Starting NCB/Plug from a Directory functional block shows only the Directory window from which only Directory information may be configured or printed.

If LonMaker is currently in “Offnet” mode, only the configuration functions of NCB/Plug (including Directory and certain Modem and NCB Options) will be available, and “<OFFNET>” will appear in the Message Box.

If the Control Neuron device being configured is not currently attached to the network, NCB/Plug will display a “Connection Error”.

- “Yes” may be clicked to retry communication with the device after reconnecting it.
- “No” may be clicked to ignore the error and enter NCB/Plug to perform configuration functions only. In this case, “No response from <device name>” will be shown in the Message box.
- “Cancel” may be clicked to abort the load of NCB/Plug.

### Manual Dialing

A dial string can be entered directly into the Phone Number box of the main NCB/Plug window. The **Dial** button can then be used to initiate a call. The **Call Cancel** button can be used to terminate a call. Connect Strings are displayed in the Message window. Connect Status is also displayed.

### Directory Menu Item

The **Phonebook** menu item accesses the Directory and is used to edit a list of 16 phone numbers (dial strings). A **Description** field is available for each of the 16 **Number** entries. Any entry in the Directory can be accessed for dialing by using the pull-down button of the Phone Number box on the main NCB/Plug window. File -> Print to File pastes the current Directory information to Windows Notepad from where it may be saved, printed, pasted, etc.

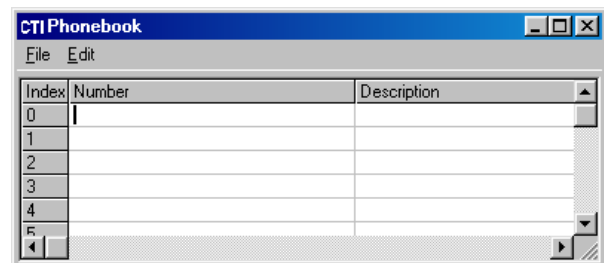

### NCB Options Menu Item

The **NCB Options** menu item provides access to the following functions:

#### Pulse Router Service Pin

This is equivalent to pressing the “RSVC” button on the NCB Units front panel.

## Soft Reboot

This is equivalent to pressing the “RESET” button on the NCB Units front panel.

## Ring Mode Parameters

NCB units connected in a Ring topology provide fault tolerance for the Telco channel. If values for Unit ID, Ring Propagation Delay, and Ping Test Interval are edited, click on **Apply Settings** to save Ring Mode Parameters. Click on the Enable/Disable menu item to display a drop-down list, then choose Enable to activate ring mode for this NCB. See “Appendix H. Ring Mode ” for further Ring Mode details.

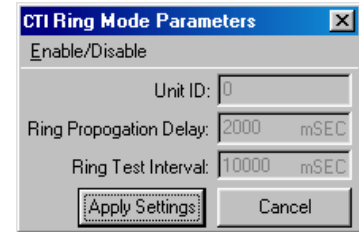

## Modem Options Menu Item

The **Modem Options** menu item provides access to the following functions for an NCB-IM and NCB-IS. These functions will have no effect for other models.

### Auto Answer (Dial-Up only)

This option allows enabling or disabling the Auto Answer function in Dial-up mode. A check next to the menu item indicates Auto Answer is currently *enabled*. Be careful when disabling Auto Answer mode on a remote NCB, as once connection with this unit is broken, it will no longer automatically answer an incoming call. To re-enable Auto Answer mode, proceed as follows:

- Press and hold the “CMD” button on the remote NCB
- Press and release the “RESET” button on the remote NCB.
- Wait until the “PWR” LED begins to flash on the remote NCB, then release the “CMD” button.

These steps will temporarily enable Auto Answer mode for the remote NCB for one incoming call. Use NCB/Plug, NCBCON, or explicit messages to re-enable Auto Answer mode for future connections.

### Mute Input Audio

To maximize data throughput, handsets should normally remain disconnected or the input audio be kept muted on any NCB that may be installed where normal background noise could be detected by the handset. Audio input is automatically un-muted when a connection is established

### Dial Mode (Dial-Up only)

*Manual* or *Perpetual* dialing modes are supported. If the modem is currently connected to another NCB, the Dial Mode will not change until the current call is cancelled.

### Connection Statistics

The Connection Statistics window appears to the right.

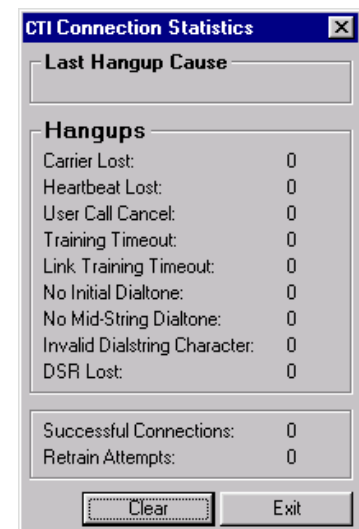



# APPENDIX

## APPENDIX A. FACTORY DEFAULT CONFIGURATION

### *Control Neuron Processor*

#### Restoring Factory Default Parameters

Should the Control Neuron Processor communication parameters be overwritten incorrectly by a network management tool, they can be restored as follows:

- Press the “RESET” button on the front of the NCB unit
- After the “ERR” LED goes off, press the “RESET” button a second time.

The Control Neuron communication parameters are now restored to factory defaults.

### *Router*

The router portion of the NCB module may be configured for various operational characteristics. The factory default configuration is as a **repeater**, where all messages entering the NCB module (via any of the three data ports described in section “1. INTRODUCTION” are simply passed through, regardless of the domain, subnet/node, or group destination address of the message. Other algorithms, as described in section “1. INTRODUCTION”, can be selected using standard LONWORKS Network Management Tools such as the LonBuilder, LonMaker, or LNS.

The communication parameters for sides A and B of the router are forced to their proper settings via NCB hardware and need not be set (nor can they be changed) by the Network Management Tool.

Further details of router operation and configuration are contained in the Echelon document entitled "LONWORKS Router User's Guide", Echelon part number 078-0018-01B.

### *Address Assignments*

The router inside the NCB module contains two Neuron chips, each with its own subnet/node number assignment. The default factory configuration of the router Neurons is subnet 255 node 126 and subnet 255 node 127. If any other nodes in the system to which the NCB is connected are configured with either of these subnet/node addresses, the router should be reconfigured to different addresses using any standard Network Management Tool.

### *Buffer Configuration*

The NCB module utilizes buffers to store incoming messages and route them out to other ports. The configuration of these buffers (the number of bytes in each buffer as well as the number of buffers) determine the maximum size message that can be passed and the performance of the NCB module under conditions of bursty traffic. In the standard configuration, the NCB router restricts the maximum size message that can be passed to a length of 40 to 50 bytes of user data, depending on the addressing overhead in the packet.

Technical Note TN010 covers the topic of buffers and buffer sizes in detail and should be referenced if messages to be passed through the NCB module could exceed the maximum default size.

### *Querying, Defaulting, and Unconfiguring Router Configuration using SETRTR.EXE*

The SETRTR.EXE DOS utility provided with each NCB can be used to query the router for its current configuration, force the router to certain default states, or force the router to *unconfigured* mode. If the router will be installed with the *configured* router algorithm, it is highly recommended that the router module is set to

*unconfigured* mode before being installed into the system (this step is mandatory if redundant routers are to be configured).

Refer to Technical Note TN025 for more information on configuration of the router with standard network management tools such as LonBuilder, LonMaker, LNS, and others.

The SETRTR program requires a network interface to be connected to the personal computer. This network interface can be an Echelon SLTA, PCLTA, PCNSS, or any other device conforming to Echelon network interface standards. Network interface driver software must be loaded in the personal computer and configured with a device name (typically, "LONn" where n is a number). Documentation provided with the network interface device details how to install the unit and driver software. The network interface device must contain a network transceiver compatible with the network transceiver in the NCB module to be controlled.

**NOTE:** *If you are using the PCLTA card as a network interface and the NCB is not performing the commands as expected, the PCNSS has probably not been configured for network interface mode. See Technical Note TN024 for information on configuring the PCNSS card into network interface mode.*

After the network interface and its software driver are properly configured on the personal computer, connect its network port to the front panel "NETWORK" connector on the NCB.

### **Querying an NCB Router for its Current Configuration**

Start the SETRTR program with the following command line:

```
SETRTR [-ddevicename] -L <cr>
```

where *devicename* is the name assigned to the network interface on the command line of the device driver (typically "LON1" or "LON2"). If this parameter is omitted, the default name of LON1 is used.

The -L parameter instructs SETRTR to List the current configuration of the router module.

After the signon message appears, press the "RSVC" button on the front of the connected NCB module. SETRTR will report the current router configuration to the screen.

### **Returning an NCB Router to Factory Default Configuration**

Start the SETRTR program with the following command line:

```
SETRTR [-ddevicename] -F <cr>
```

where *devicename* is the name assigned to the network interface on the command line of the device driver (typically "LON1" or "LON2"). If this parameter is omitted, the default name of LON1 is used.

The -F parameter instructs SETRTR to set the RTR-10 to full Factory defaults, including router algorithm, domain tables, and buffer settings.

After the signon message appears, press the "RSVC" button on the front of the connected NCB module. SETRTR will send the required messages to the router and exit. Press the "RESET" button on the front of the NCB module to complete the reconfiguration.

### **Setting an NCB Router to Unconfigured Mode**

Start the SETRTR program with the following command line:

```
SETRTR [-ddevicename] -U <cr>
```

The -U parameter instructs SETRTR to set both sides of the NCB Units router to Unconfigured mode.

After the signon message appears, press the "RSVC" button on the front of the connected NCB module. SETRTR will send the required messages to the router and exit.

## APPENDIX B. MOUNTING OPTIONS

Wall mount and EIA 19" rack mount kits are available as options for the NCB from CTI Products, Inc. The wall mount kit includes brackets to allow a single NCB module to be mounted to any flat surface. The rack mount kit includes an adapter allowing up to three NCB modules to be mounted in a single rack unit height.

### **Rack Mount Option**

The rack mount option allows up to three NCB modules to be mounted in a one rack unit height (1.75 inches) of a standard 19 inch rack. The modules are mounted in the rack plate by removing its front bezel and remounting the module into the rack plate. Figure 9 shows an exploded view of the rack mount installation. The top diagram shows the front view of the bracket with one module installed. The bottom two diagrams show a side view of the module installation into the rack adapter and rack adapter installation into the rack, respectively.

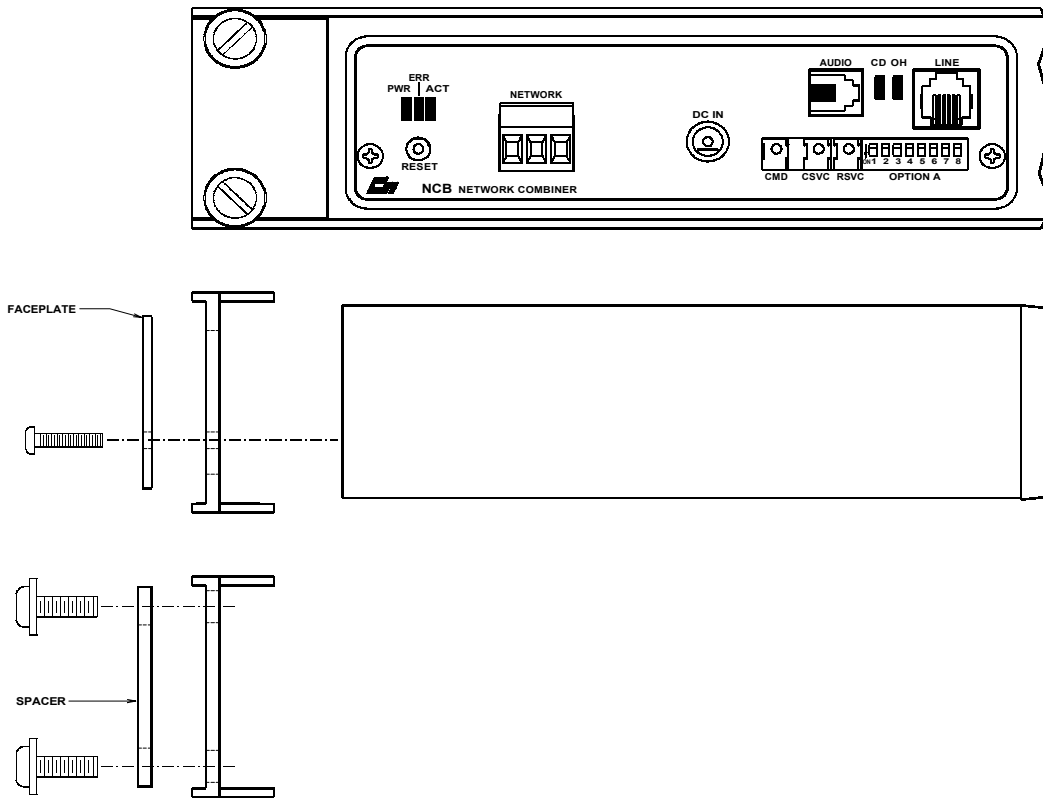

CA-80113-100

*Figure 9 NCB Module Rack Mounting*

To attach a module to the rack adapter, and then mount the rack adapter into the rack, follow the steps below.

**WARNING**

Do not allow the PC board to slide out of the housing when the front panel is removed. If it does, **DO NOT** slide the PC board back into the housing from the front of the module. Doing so may damage the unit, causing the unit to malfunction when powered on. Doing so will void the unit's warranty.

**Rack Mounting Instructions**

Step	Operation
1	Remove the front panel from the module, including the bezel, by removing the two Philips head screws in the faceplate. The bezel is not used when rack mounting the module.
2	Position the module behind the rack adapter, lining up the holes in the rack adapter with the front panel screw holes on the module.
3	Position the front panel in front of the rack adapter, lining up the front panel with the module.
4	Fasten the front panel and module to the rack adapter with the Philips head screws that were previously removed.
5	Position the rack adapter into your rack, lining up the four mounting holes of the rack adapter with mounting holes in the rack frame.
6	Position the two spacers in the front of the rack adapter, aligning the cutouts in the spacers with the holes of the adapter.
7	Install mounting screws (customer provided) into the rack.

When the module's front panel is removed, do not allow the PC board to slide out of the housing. If the PC board does slide out of the housing, you must follow the steps below to replace the PC board in the housing. **DO NOT RE-INSTALL THE PC BOARD FROM THE FRONT OF THE HOUSING !**

**Re-Installing a PC Board in its housing**

Step	Operation
1	From the front of the module, slide the PC board out of the housing.
2	Remove the back panel of the module.
3	From the rear of the module, slide the PC board back into the housing (there are markings on the PC board to indicate which edge to insert into the rear of the housing first).
4	Install the back panel of the module.

### Wall Mount Option

The wall mount option allows an NCB module to be mounted to any flat surface. The NCB module has four screw holes on the bottom. Simply attach the two mounting plates to the bottom of the module using the four flat-head screws provided with the wall mount kit. This assembly is then attached to the flat surface with user-provided fasteners. Figure 10 shows a dimensioned view of the wall mount installation.

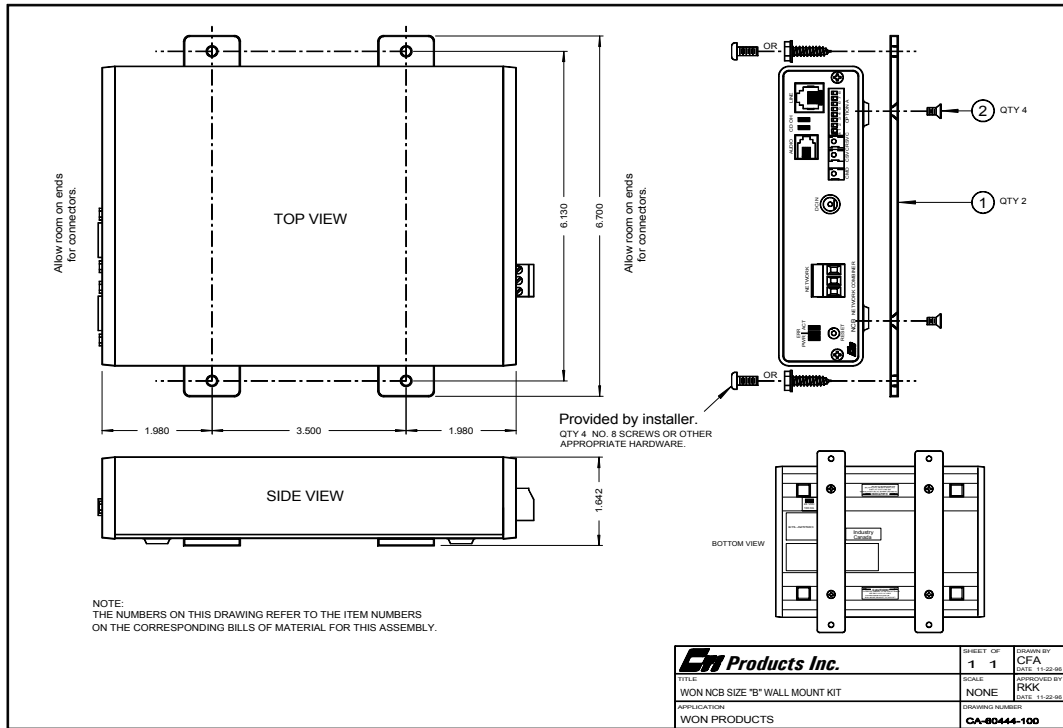

Figure 10 NCB Module Wall Mounting

#### CAUTION

Be sure to use the flat head screws provided with the wall mount kit. If you are not using the wall mount kit from CTI Products, Inc., make sure that the screws do not protrude into the enclosure more than 0.125 inches from the bottom surface of the module.

Using a longer screw that touches the PC board inside the module may damage the module. Doing so will void the unit's warranty.

## APPENDIX C. CONNECTOR DETAILS

### DC IN Connector

Connector type: 2.5 x 5.5 mm coaxial  
 Mating Connector: Switchcraft 760 or equivalent  
 Connector pinout: CTI Products, Inc. standard power supply wired with center pin positive, NCB module can accept either pin positive, polarity routing is provided internal.

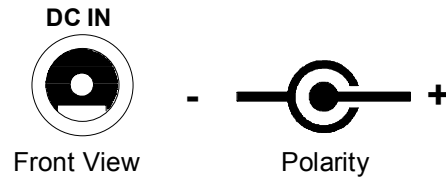

### NETWORK Connectors

RJ45 Connectors:

Pins 1 and 2 of both RJ45 connectors as well as the terminal strip pins are all wired in parallel. The dual RJ45 connector designates "IN" and "OUT". These designations apply only to DC power that is passed down unused pairs of the 4 pair network cable. The two pins carrying the network pair are straight-through.

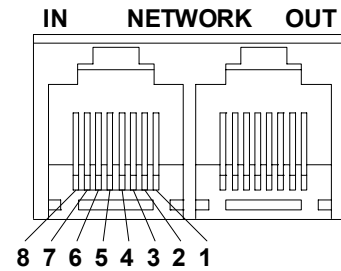

Connector Type: Standard RJ45 telephone connector, 8 position 8 contact.

Pin	Function	Notes
1	Network	Network connection is NOT polarity sensitive
2	Network	Pins 1,2 of IN and OUT connectors tied parallel
3	+ DC Power	In on IN connector, Out on OUT connector
4	No Connection	
5	No Connection	
6	- DC Power	In on IN connector, Out on OUT connector
7	- DC Power	In on IN connector, Out on OUT connector
8	+ DC Power	In on IN connector, Out on OUT connector

2 Pin Terminal Strip style:

Mating Connector: Weidmuller 128176

Pin	Function
1	Network
2	Network

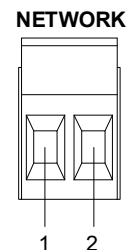

3 Pin Terminal Strip style:

Mating Connector: Weidmuller 128186

Pin	Function
1	Network
2	Network
3	Shield (RS-485 only)

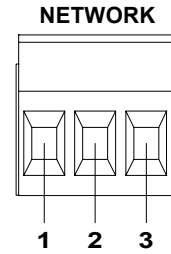

CA-80085-100

SMX Transceiver units:

SMX network connections are described in the documentation with the SMX transceiver.

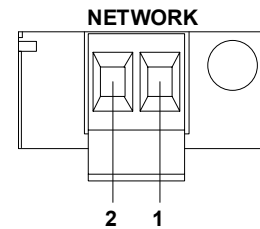

**PORT 1 and PORT 2 Connectors**

Connector type: Standard DE9 male

Data Format: 8 data bits, 1 stop bit, no parity

Data Characteristics: A series of bytes entering the "PORT 1" or "PORT 2" connectors must not have gaps between bytes greater than 500ms.

Handshaking: Activating the DSR input signal informs the NCB unit that the channel is active. If the channel does not directly support DSR, it must be strapped back to the (always active) DTR output signal.

Flow Control: CTS/RTS flow control can be used to pace the transmission of individual bytes between the NCB and a connected device. Sensing of CTS by the NCB can be enabled/disabled with the Option B switches. (See "STEP 2. SWITCH SETUP", in section "2. SETUP AND OPERATION".)

Miscellaneous: Pinout as DTE, arranged for direct connection to 25 pin connector using standard 9 pin to 25 pin cable. All signals except RI must be connected for proper operation.

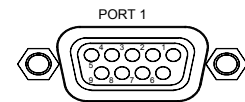

NCB Pin	Function	Direction	Modem Pin
1	DCD	Channel → NCB	8
2	RXD	Channel → NCB	3
3	TXD	NCB → Channel	2
4	DTR	NCB → Channel	20
5	ground		7
6	DSR	Channel → NCB	6
7	RTS	NCB → Channel	4
8	CTS	Channel → NCB	5
9	RI	Channel → NCB	22

## APPENDIX D. NCB VERSION COMPARISON

Feature	Version 3 Operation	Version 2 Operation
Using a Network Management Tool (with OPTION A Switch 5 in the DOWN position)	When OPTION A Switch 5 is in the DOWN position, the <i>Auto-Answer Enabled/Disabled</i> setting due to NCB/Plug or Network Variables is non-volatile. (The setting of OPTION A Switch 1 will be ignored.)	Regardless of the setting of OPTION A Switch 5, the <i>Auto-Answer Enabled/Disabled</i> setting in NCB/Plug is volatile. Following a power cycle or reset, the setting of OPTION A Switch 1 will determine the <i>Answer/Originate</i> mode.  (When using NCB/Plug to control the <i>Answer/Originate</i> mode of the NCB, NCB/Plug's reference to 'Auto-Answer Enabled' is equivalent to <i>Answer</i> mode. 'Auto-Answer Disabled' is equivalent to <i>Originate</i> mode.)
CMD Button operation	Holding the CMD Button depressed during a power cycle or reset will temporarily enable <i>Auto-Answer</i> mode. This feature is useful if an NCB that must answer calls is inadvertently placed in <i>Auto-Answer Disabled</i> mode. When this feature is utilized, the NCB will answer a single call before reverting back to <i>Auto-Answer Disabled</i> mode. During this single answered call, NCB/Plug may be used to change the mode to <i>Auto-Answer Enabled</i> so that future calls may be answered.	CMD Button has no function.

## APPENDIX E. TROUBLESHOOTING

Table E1

If the PWR LED . . .	REASON	CORRECTIVE ACTION
Is always illuminated.	Normal operation indicating that NCB unit is receiving proper DC input power.	Go to next Table.
Flashes for 2 seconds.	Normal operation when WINK command is being executed.	Go to next Table.
Flashes continuously.	DC input to unit is below minimum required voltage.	Check for proper voltage at "DC IN" connector (10-32VDC).
Does not illuminate.	NCB unit is not receiving DC input power.	Check for proper voltage at "DC IN" connector (10-32VDC).

Table E2

If the ERR LED . . .	REASON	CORRECTIVE ACTION
Is always off.	Normal operation indicating no error condition was detected.	Goto next Table.
Occasionally blinks on, then off.	Normal operation when "CSVC" button or "RSVC" button is pressed.	Go to next Table.
Flashes slowly, at a rate of once every 2 seconds.	The Router Neurons are unconfigured.	Use a Network Management Tool to 'Replace' or 'Commission' router, or Use NODEUTIL to change the mode/state to 'Configured' and 'On-line', or Use SETRTR -F to configure the router to Factory default conditions (Repeater Mode).
Flashes quickly, at a rate of twice per second.	1. A serial "PORT" is enabled, but is not terminated correctly to an active device.	1a. Either disable the serial "PORT" (setting the appropriate <b>BAUD</b> switch to '0', or 1b. Terminate the serial "PORT" in an active device such as another NCB, a modem, or ISDN modem.
Is always illuminated.	Router module, or Control Neuron Processor, or Microprocessor is not functioning.	Call CTI Products, Customer Support (+1-513-595-5900), to arrange to return unit for evaluation/repair.

Table E3

If the LS LED . . .	REASON	CORRECTIVE ACTION
Illuminates within 60 seconds of resetting ISDN modem.	Normal operation indicating the ISDN modem is communicating to the telco switch using a D (Data) channel.	Go to next Table.
Does not illuminate within 60 seconds of resetting ISDN modem.	<ol style="list-style-type: none"> <li>1. ISDN modem has not been configured.</li> <li>2. ISDN modem is not communicating to the telco switch using a Data channel.</li> <li>3. Defective ISDN modem.</li> </ol>	<ol style="list-style-type: none"> <li>1. Configure the ISDN modem using software utility supplied by adapter manufacturer.</li> <li>2. Contact line provider for line status.</li> <li>3. Call CTI Products, Customer Support (+1-513-595-5900), to arrange to return unit for evaluation/repair.</li> </ol>

Table E4

If the B1 or B2 LED . . .	REASON	CORRECTIVE ACTION
Illuminates immediately when a connection is attempted.	Normal operation indicating the ISDN modem is communicating to the telco switch using a B (Bearer) channel.	Go to next Table.
Does not illuminate on <b>originating</b> ISDN modem when a connection is attempted.	<ol style="list-style-type: none"> <li>1. ISDN modem has not been configured.</li> <li>2. ISDN modem is not communicating to the telco switch using a Bearer channel.</li> <li>3. Defective ISDN modem.</li> </ol>	<ol style="list-style-type: none"> <li>1. Configure the ISDN modem using software utility supplied by adapter manufacturer.</li> <li>2. Contact line provider for line status.</li> <li>3. Call CTI Products, Customer Support (+1-513-595-5900), to arrange to return unit for evaluation/repair.</li> </ol>

Table E5

If the ACT LED (on local NCB) . . .	REASON	CORRECTIVE ACTION
Occasionally blinks on, then off.	Normal operation indicating a message packet has passed through the router module of the NCB.	Go to next Table.
Does not illuminate when "RSVC" button on remote NCB is pressed.	<ol style="list-style-type: none"> <li>1. LONWORKS Service Pin message from <b>remote</b> NCB is not reaching the remote modem.</li> <li>2. LONWORKS Service Pin message from <b>remote</b> NCB is not reaching the <b>local</b> ISDN modem.</li> <li>3. LONWORKS Service Pin message from <b>remote</b> NCB is not reaching the <b>local</b> NCB.</li> <li>4. LONWORKS Service Pin message from <b>remote</b> NCB is not passing through the local router module.</li> </ol>	<ol style="list-style-type: none"> <li>1a. Verify that "ACT" and "ERR" LED's on <b>remote</b> NCB flash once. If not, return <b>remote</b> unit for evaluation/repair.</li> <li>b. Verify that "B" LED is illuminated on the local and remote ISDN modem s. (See above)</li> <li>c. Verify that "TD" LED briefly illuminates on <b>remote</b> ISDN modem when the "RSVC" button is pressed on <b>remote</b> NCB.</li> <li>d. If '1c' is not ok, check serial cable connection between <b>remote</b> NCB and ISDN modem.</li> <li>2. Verify that "RD" LED briefly illuminates on <b>local</b> ISDN modem when the "RSVC" button is pressed on <b>remote</b> NCB.</li> <li>3. Check serial cable connection between the <b>local</b> NCB and ISDN modem.</li> <li>4a. Place the <b>remote</b> router in Repeater mode and verify that the <b>local</b> "ACT" LED illuminates when "RSVC" button on <b>remote</b> NCB is pressed.</li> <li>b. If '4a' is ok, re-commission the <b>local</b> NCB router.</li> <li>c. If '4a' is not ok, swap either the local or remote unit with a known-good-unit to determine the faulty unit.</li> </ol>
Does not illuminate when local LONWORKS nodes are transmitting messages.	<ol style="list-style-type: none"> <li>1. LONWORKS message packets from <b>local</b> nodes are not passing through the <b>local</b> router module.</li> </ol>	<ol style="list-style-type: none"> <li>1a. Verify the connection between the <b>local</b> LONWORKS nodes and the <b>local</b> NCB.</li> <li>b. Place the <b>local</b> router in Repeater mode and verify that its "ACT" LED illuminates when local LONWORKS nodes are transmitting messages.</li> <li>c. If '1b' is ok, re-Commission the <b>local</b> NCB.</li> <li>d. If '1b' is not ok, return the <b>local</b> NCB unit for evaluation/repair.</li> </ol>

Table E5 continued on next page 

<p>Does not illuminate when remote LONWORKS nodes are transmitting messages.</p>	<ol style="list-style-type: none"> <li>1. LONWORKS message packets from <b>remote</b> nodes are not passing through the <b>remote</b> router module.</li>   <li>2. LONWORKS message packets from <b>remote</b> nodes are not reaching the local NCB.</li>   <li>3. LONWORKS message packets from <b>remote</b> nodes are not passing through the <b>local</b> router module.</li> </ol>	<ol style="list-style-type: none"> <li>1a. Verify the connection between the <b>remote</b> LONWORKS nodes and the <b>remote</b> NCB.</li> <li>b. Verify that “ACT” LED on <b>remote</b> NCB illuminates when <b>remote</b> LONWORKS nodes are transmitting messages.</li> <li>c. Place the <b>remote</b> router in Repeater mode and verify that its “ACT” LED illuminates when <b>remote</b> LONWORKS nodes are transmitting messages.</li> <li>d. If ‘1c’ is ok, re-commission the remote router.</li> <li>e. If ‘1c’ is not ok, return unit for evaluation/repair.</li> <li>2. See this Table above and verify that the “ACT” LED “Does not illuminate when “RSVC” button on <b>remote</b> NCB is pressed”.</li> <li>3. See this Table above and verify that the “ACT” LED “Does not illuminate when “RSVC” button on <b>remote</b> NCB is pressed”.</li> </ol>
--	---	--

Table E6

Miscellaneous:	REASON	CORRECTIVE ACTION
<p>Cannot communicate with Control Neuron Processor of <b>local</b> NCB when using NODEUTIL.</p>	<ol style="list-style-type: none"> <li>1. In Bridge or Configured modes, router neurons and network interface are not in the same domain.</li> <li>2. In Repeater mode, the network interface may be defective.</li> </ol>	<ol style="list-style-type: none"> <li>1. Verify that Nodeutil can communicate with another LONWORKS node.</li> <li>2a. Place the local router neurons in Repeater mode and verify that communications is possible, or</li> <li>b. Use Nodeutil to change the network interface Domain to match the router neurons’ domains.</li> </ol>
<p>Cannot communicate with the Control Neuron Processor of local NCB when using NCBCON.</p>	<ol style="list-style-type: none"> <li>1. In Bridge or Configured modes, the Control Neuron, the router neurons, and the network interface are not all in the same domain. (2)</li> <li>2. In Repeater mode, the Control Neuron and network interface are not in the same domain. (1)</li> </ol>	<ol style="list-style-type: none"> <li>1. Place the local router neurons in Repeater mode.</li> <li>2. Use NCBCON to change the network interface Domain to match the Control Neuron domain.</li> </ol>
<p>Cannot commission the Control Neuron Processor when using LonMaker for Windows.</p>	<p>Incorrect external interface definition (.xfb or .xif file) was specified when commissioning node.</p>	<p>Use NCBTLC30 for Version 3 NCB Units. Use NCBTLC20 for NCB Units prior to Version 3.</p>

---

## APPENDIX F. SPECIFICATIONS

### **NCB Unit**

DC Power Input:	<i>10 to 30 VDC, Negative Ground, Externally Current Limited 5 watts maximum without SMX transceiver 10 watts maximum with SMX power line transceiver</i>
Size:	<i>7.5" D x 5.6" W x 1.6" H</i>
Operating Temperature:	<i>0 to 60 °C</i>
Humidity:	<i>10-95% non-condensing</i>
Mounting:	<i>Desktop with integral non-slip feet Wallmount or 19" rack mount with optional adapters</i>
Transceivers supported:	<i>FTT-10A, TPT/XF-78, TPT/SF-1250, SMX</i>
Maximum packet size:	<i>66 bytes (factory default router configuration) 255 bytes (maximum with software re-configuration)</i>
Dialing:	<i>LONMARK<sup>®</sup> 3.2 Modem Controller and Telephone Directory, SNVTs or Explicit messages</i>
Serial Ports:	<i>2 Ports, one or two modems or adapters may be connected 1200 to 115200 bps 8 data bits, 1 stop bit, no parity</i>
Configuration:	<i>Factory default router mode is set to Repeater. Configured or Bridge mode set using standard LONWORKS network management tools capable of configuring routers.</i>
Installation:	<i>Can be done with Standard Network Tools</i>
LONMARK <sup>®</sup> 3.2 Objects	<i>Modem Controller 5091 Telephone Directory 5092</i>
LONMARK <sup>®</sup> Program ID:	<i>80:00:60:32:5B:08:09:32</i>

### **ISDN Modem**

Power:	<i>9 VDC 300 mA (MTA128 only), Country-specific AC adapter included.</i>
Size:	<i>6.0" D x 4.25" W x 1.0" H (MTA128 only)</i>
Temperature:	<i>0-50 °C</i>
ISDN Interface:	<i>Available with either 2-wire U-type or 4-wire S/T-type interface. U interface (NT suffix) modem supports 5ESS, DMS-100, INS64, and NI-1 Switch types. S/T interface (ST suffix) modem supports ETSI/NET3, DBP ITR6, VN4, INS64, NI-1, 5ESS, and DMS-100 Switch types</i>
Telecom Approvals:	<i>Pan European (EC Countries), United States, Canada</i>
ISDN Data Rate:	<i>64 Kbps, 128 Kbps by bonding both B channels</i>



---

## APPENDIX G. MODEM NOTES

### ***EuroISDN Switch Type***

If the switch type at the telephone company's central office is 'EuroISDN' (also designated "ETSI" or "NET3"), and the ISDN modem used is Multitech model MTA128ST, no configuration of the ISDN modem is needed.

### ***Other Switch Types***

Configuration for all other instances of the ISDN modem must be performed before it can communicate with the telco central office switch. This configuration process is only required once (when the ISDN modem is first configured for use with the NCB) and uses software provided with the ISDN modem. The following information (provided by the installer of the ISDN phone lines to which the adapters will be connected) is required to complete this configuration:

- Network Switch Type, i.e. 5ESS, NI-1, DMS-100, INS64, ETSI/NET3, 1TR6, VN4
- The Data and Voice Terminal Endpoint Identifiers (TEI). If none are given, these can be automatically set.
- The Data and Voice "Directory Numbers" (DNs)
- Service Profile Identifiers (SPIDs), if used in North America or Japan

More details about ISDN can be found in TECHNICAL TUTORIAL TT002 "INTRODUCTION TO ISDN".

When the above information is known, configuration of the ISDN modem can take place.

### **Multitech MTA128 ISDN Modem Configuration**

MTA128-ST is preconfigured to work with the EuroISDN switch type and is ready to connect to the 4-wire S/T-type interface. MTA128-NT is not preconfigured, and must be connected to the 2-wire U-type interface.

Connect the ISDN modem to an available COM port on the PC, power-up the modem, and install and start the "ISDN TA Configuration Utility" that was provided with the modem. Proceed with the responses for the following steps:

- a) **"Welcome"** window:  
Select **YES**, then click **NEXT** to have the program automatically find the modem.
- b) **"Searching for TA"** window:  
Once modem is found, click **NEXT** to continue.
- c) **"Configuration"** window:  
In "Setup" click the down arrow and click on **"Custom (New)"**. Click **NEXT** to continue.
- d) **"Network Switch Type"** window:  
Select the proper "Network Switch Type". Click **NEXT** to continue.
- e) **"TEI"** window:  
Select the proper **Data TEI** and **Voice TEI**. If none are specified, select **"Auto TEI"**. Click **NEXT** to continue.
- f) **"SPID"** window:  
Enter the proper **Data Directory Number**, **Voice Directory Number**, **Data SPID**, and **Voice SPID**. **Do NOT include dashes or parentheses in these numbers**. All fields in this window should remain blank if the "Network Switch Type" is "NET3". Click **NEXT** to continue.
- g) **"Call Control Setup"** window:  
Leave all selections as default. Click **NEXT** to continue.
- h) **"Data Protocol Setup"** window:  
Ensure **Data Protocol** is selected as **"V.120"**. Leave all other settings as default. Click **NEXT** to continue.
- i) **"Stored Numbers"** window:  
Leave all selections as default. Click **NEXT** to continue.

- j) **“Port Control Setup I”** window:  
Select **DSR Signal as “Always On”**. Leave all other selections as default. Click **NEXT** to continue.
- k) **“Port Control Setup II”** window:  
Leave all selections as default. Click **NEXT** to continue.
- l) **“Save Configuration”** window:  
Enter a filename to use in recalling this configuration for future setups. Click **NEXT** to continue.
- m) **“Load Configuration”** window:  
Load the configuration. The **“Configuring”**, then **“Configured”** windows should appear in order, indicating that the configuration information has been loaded into the modem. Click **FINISH** to complete the configuration.

## U.S. Robotics Courier-I ISDN Modem Configuration

Connect the ISDN modem to an available COM port on the PC, power-up the modem, and install and start the “I Modem Configuration ISDN Program” that was provided with the adapter. Proceed with the responses for the following steps:

- a) **Startup screen:**  
Select the **COM** port that the modem is connected to and click **Open COM Port** to continue.
- b) **U.S. Robotics COURIER-I modem Configuration** window:
  - Data Channel:**
    - Call Type: . . . . . Select **“V.120 Rate Adaptation”**
    - Service Profile ID: . . . . For North America, enter the **SPID** provided for the data channel. (This is not needed in Europe.)  
*Do NOT include dashes or parentheses in these numbers.*
    - Directory Number: . . . . Enter the **DN** provided for the data channel.  
*Do NOT include dashes or parentheses in these numbers.*
    - Terminal Endpoint ID: . Enter the **TEI** provided for the data channel, or **“00”** if no **TEI** provided.
  - Analog Device Channel:**
    - Dialing Method . . . . . Select **“Standard Analog”**
    - Call Type . . . . . Select **“Speech”**
    - Service Profile ID . . . . For North America, enter the **SPID** provided for the voice channel. (This is not needed in Europe.)
    - Directory Number . . . . Enter the **DN** provided for the voice channel
    - Terminal Endpoint ID . Enter the **TEI** provided for the voice channel, or **“00”** if no **TEI** provided
  - Switch Protocol Type . . . . Select the proper Network Switch Type**
- c) Click **SAVE** to send these configurations to the modem.

## APPENDIX H. RING MODE

The NCB-International module can be configured to allow a group of NCBs to be connected in a ring topology via their RS232 serial ports as shown in Figure 11 (note that the external modems are not shown but are implied):

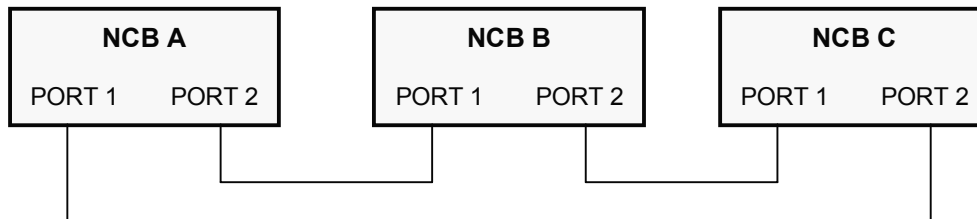

*Figure 11 NCB Units Connected in Ring Mode*

Up to 64 NCB modules can be connected together in such a ring. Connection order is not significant (“PORT 1” of one unit can be connected to either “PORT 1” or “PORT 2” of the other unit). Using this topology, any LonTalk message entering one NCB unit is distributed to all of the other NCB units in a redundant manner such that the communication system will remain functional even if the ring is broken in any ONE place. The status of the ring (open or closed) is available by request from the control neuron of any of the NCB members.

***Note:** If a set of NCB-International modules are connected as shown in the figure above with all of the NCB units configured for NON-RING mode, a single LonTalk message entering any one of the NCB units will "loop forever" in the ring, causing saturation of the communication system. THEREFORE, ALWAYS BE CERTAIN TO CONFIGURE AT LEAST ONE OF THE NCBs TO ENABLE RING MODE (as explained below) BEFORE COMPLETING THE RING AS SHOWN ABOVE. For Ring Mode to function properly, ALL NCB modules in the ring must be configured with Ring Mode Enabled. Additionally, messages placed on the ring by NCB modules configured in non-ring mode will be ignored and dropped from the ring by NCB modules configured in ring mode, and vice-versa.*

For operation in ring mode, all NCB modules in the ring must be configured to **enable** ring mode.

Each NCB module in the ring must be assigned a unique *Unit Number* from 1 to 64. An NCB can be set to *Unit Number* 0 in order to connect it into the ring as a "non-participatory" unit. This can be used to determine what other unit numbers already exist in the ring in order to choose one that will not conflict with any others. This "non-participatory" unit can be changed to an active unit by then changing its unit number to some non-zero value that is not already in the ring.

Additionally, the maximum expected **ring propagation delay** and desired **test interval** parameters must be specified. The **ring propagation delay** is used to set timeout values for ring maintenance packets and must have a value between 1000 and 7500ms. The **test interval** sets the frequency of ring maintenance packets that determine ring status, duplicate unit number faults, and sequence number resynchronization. The **test interval** must have a value between 10000 and 65000ms.

The NCB/Plug plug-in can be used to set Ring Mode parameters.

The NCBCON.EXE DOS utility can be used to set Ring Mode parameters and also to query the ring status. See Technical Note TN023, “Using NCBCON to Configure an NCB”.

## Connection and Enabling Procedure

The following steps should be followed when installing a series of NCB modules for *Ring Mode* operation:

- 1) Connect all NCB modules in default mode (*Ring Mode* disabled).
  - a) During installation of each NCB, enable both NCB serial ports using the appropriate “BAUD” and “MODE” settings for switches on the rear panel.
  - b) Then press the “RESET” button on the front panel. (The front panel “ERR” LED will blink rapidly if both serial ports are not terminated at another functioning device.)
- 2) Be certain that the ring is open in one place. It is usually convenient to remove the cable from one of the serial “PORT” connectors on the rear of the NCB, leaving the other one connected.
- 3) From the Central Site, with all Remote Site NCB Units communicating, set *Ring Mode* parameters and enable *Ring Mode* on the Remote Site NCB Units.
  - a) Begin by enabling *Ring Mode* for the NCB located just before the ring opening. (This will be the furthest NCB around the ring, even though it may be very near the Central Site.) Once *Ring Mode* has been enabled for an NCB, it will not communicate with other NCB Units in the ring until **all** are enabled for *Ring Mode*.
    - i) If the LonMaker for Windows browser is being used to enable *Ring Mode* (using the configuration property UCPT\_RingMode), a message may appear: “WARNING WHILE DOWNLOADING CP’S TO DEVICE”. This is understandable, since communication with other units in the ring is discontinued until all units are enabled for *Ring Mode*. Since communication is discontinued, the device shape representing the Control Neuron on the LonMaker drawing will indicate a “Node Error”.
    - ii) If the NCB/Plug plug-in is being used to enable *Ring Mode*, NCB/Plug will automatically close, since communications to that NCB is no longer possible until all remaining NCB Units are set to *Ring Mode*.
  - b) Enable *Ring Mode* for the next closest NCB around the ring. Finish by enabling *Ring Mode* for the NCB at the Central Site.
- 4) Close the ring.

Communication is now possible and the device shapes representing the Control Neurons of each NCB on the LonMaker drawing will indicate “Node Normal”.

## Disabling Procedure

The following steps should be followed when disabling *Ring Mode* operation for a series of NCB modules:

- 1) Open the ring by removing the cable from one of the serial “PORT” connectors on the rear of the NCB at the Central Site.
- 2) With all Remote Site NCB Units communicating, disable *Ring Mode* on the Remote Site NCB Units:
  - a) Begin by disabling *Ring Mode* for the NCB located just before the ring opening. (This will be the furthest NCB around the ring, even though it may be very near the Central Site.) Once *Ring Mode* has been disabled for an NCB, it will not communicate with other NCB Units in the ring until **all** are disabled for *Ring Mode*.
  - b) Disable ring mode for the next closest NCB around the ring. Finish by disabling ring mode for the NCB at the Central Site.

To prevent the “ERR” LED from continually blinking, disable any NCB serial “PORT” no longer in use, using the appropriate “BAUD” and “MODE” settings for switches on the rear panel. Then press the “RESET” button on the front panel.



# INDEX

<b>A</b>	
ACT LED.....	6
Addressing.....	9
Auto Answer Mode.....	7, 29
<b>B</b>	
BAUD Switches.....	10
Bridge.....	5
Buffer Configuration.....	31
<b>C</b>	
Call Cancel.....	19
<i>CMD Button</i> .....	7, 29, 38
Commissioning an NCB.....	13, 14
<b>Configuration Properties</b> .....	25, 26
Configured router.....	5, 31
Connection Statistics.....	29
Connector.....	36
Connectors.....	36
Control Neuron Processor.....	4, 6, 9, 14, 15, 31
<b>D</b>	
Dial String.....	25
DN (Directory Number).....	12, 44
Domain.....	5, 31, 32
DSR/DTR.....	10
<b>E</b>	
ERR LED.....	6, 10, 31
Error.....	6, 20
Explicit Messages.....	5
External modem.....	4, 11
<b>F</b>	
Factory Default Parameters.....	31
Front Panel.....	6
Functional Block.....	17
<b>I</b>	
Internal router.....	4, 6, 17, 31
ISDN.....	1, 10, 12, 44
<b>L</b>	
LINE connector.....	4
LNS Plug-In.....	27
LONMAKER for Windows.....	13
LONMARK.....	3, 17, 43
LONWORKS.....	4, 14
<b>M</b>	
Message Buffer.....	5
Mode Switches.....	11
MODEM.....	1, 12
Modem Controller object.....	17, 18, 21, 24, 25
Modem Notes.....	44
Mounting.....	33
Mounting Kit.....	9
Mute Input Audio.....	29
<b>N</b>	
NCB/Plug Configuration Plug-In.....	ii, 16, 27
NCB/Plug Installation.....	27
NCBCON.....	5, 13
NETWORK connector.....	4, 11, 32
Network Management Tool.....	6, 9, 13, 31
Network Switch Type.....	12, 44
Network Variables.....	16, 24
<b>O</b>	
Object -- Modem Controller.....	18, 24
Object -- Telephone Directory.....	24
Objects -- Global Control.....	25
OPTION A Switches.....	9
OPTION B Switches.....	10
<b>P</b>	
PCNSS Card.....	5
Perpetual Dial Mode.....	21
Plug-In.....	27
PORT 1.....	4, 10, 11, 37, 39
PORT 2.....	4, 10, 11, 37
Power Connection.....	12
Pulse Router Service Pin.....	28
PWR LED.....	6
<b>R</b>	
Rear Panel.....	7
Repeater.....	5, 31
Ring Mode.....	4, 6, 26, 29, 46
RJ45.....	11, 36
<b>S</b>	
Serial port.....	4, 6, 10, 46
Serial Port Handshaking.....	10
SETRTR.EXE.....	31
Soft Reboot.....	29
Specifications.....	43
SPID (Service Profile Identifier).....	12, 44
Subnet/node.....	5, 9, 31
<b>T</b>	
TEI (Terminal Endpoint Identifier).....	12, 44
Telephone Directory object.....	17, 24, 25, 28

<i>W</i>		<i>X</i>	
Wink.....	6	XIF Files .....	14



