

Model NCB-RF

Network Combiner Module

Wide Area Router for LONWORKS® Networks

User Guide # S2-60696-305



Standard Limited Hardware Warranty

LIMITED WARRANTY. Equipment manufactured by CTI Products, Inc. is warranted to be free from defects in material and workmanship for a period of ONE (1) YEAR from date of shipment to original purchaser. Under this warranty, our obligation is limited to repairing or replacing any equipment proved to be defective by our inspection within one year of sale to the original purchaser. This warranty shall not apply to equipment which has been repaired outside our plant in any way, so as to, in the judgment of CTI Products, Inc. affect its stability or reliability, nor which has been operated in a manner exceeding its specifications, nor which has been altered, defaced, or damaged by lightning.

CUSTOMER REMEDIES. In the event of a defect, malfunction, or failure to conform to specifications established by the seller during the period shown, the customer shall call CTI Products, Inc. to obtain a Return Authorization Number and return the product or module, shipping and insurance prepaid. CTI Products, Inc., will then at its option, either repair or replace the product or module and return it, shipping prepaid, or refund the purchase price thereof. On-site labor at the purchaser's location is not included in this warranty.

EQUIPMENT NOT MANUFACTURED BY CTI Products, Inc. Equipment not manufactured by CTI Products, Inc. is excluded from this warranty, but is subject to the warranty provided by its manufacturer, a copy of which will be supplied to you upon specific written request.

NO OTHER WARRANTIES. The foregoing constitutes the sole and exclusive remedy of the buyer and exclusive liability of CTI Products, Inc., AND IS IN LIEU OF ANY AND ALL OTHER WARRANTIES EXPRESSED OR IMPLIED OR STATUTORY AS TO MERCHANTABILITY, FITNESS FOR PURPOSE SOLD, DESCRIPTION, QUALITY, PRODUCTIVENESS OR ANY OTHER MATTER.

NO LIABILITY FOR CONSEQUENTIAL DAMAGES. WITHOUT LIMITING THE FOREGOING, IN NO EVENT SHALL CTI PRODUCTS, INC. OR ITS SUPPLIERS BE LIABLE FOR ANY DAMAGES WHATSOEVER (INCLUDING, WITHOUT LIMITATION, SPECIAL, INCIDENTAL OR CONSEQUENTIAL DAMAGES OR FOR LOSS OF BUSINESS PROFITS, BUSINESS INTERRUPTION, LOSS OF BUSINESS INFORMATION, OR OTHER PECUNIARY LOSS) ARISING OUT OF THE USE OF OR INABILITY TO USE CTI PRODUCTS, INC. EQUIPMENT BY PURCHASER OR OTHER THIRD PARTY, WHETHER UNDER THEORY OF CONTRACT, TORT (INCLUDING NEGLIGENCE), INDEMNITY, PRODUCT LIABILITY OR OTHERWISE, EVEN IF CTI PRODUCTS, INC. HAS BEEN ADVISED OF THE POSSIBILITY OF SUCH DAMAGES OR LOSSES. IN NO EVENT SHALL CTI PRODUCTS, INC.'S, LIABILITY EXCEED THE TOTAL AMOUNT PAID BY PURCHASER FOR THE EQUIPMENT GIVING RISE TO SUCH LIABILITY.

Location: **CTI Products, Inc**
 1211 West Sharon Road
 Cincinnati, OH 45240 USA

Phone: +1.513.595.5900

Fax: +1.513.595.5983

Web: www.ctiproducts.com

E-mail, Sales: info@ctiproducts.com

Technical Support: lwsupport@ctiproducts.com

This manual covers NCB units of Revision 300 or higher and NCB/Plug software revision 1.00 or higher. The NCB Unit Revision can be found on the rear of the unit following the letter "U". The NCB/Plug software revision can be found on the Help/About screen of the program. If the revision of the product in hand is greater than that shown above, there may be additional features supported by the product that are not covered in this manual.



Information contained in this document is subject to change without notice and does not represent a commitment on the part of CTI Products, Inc.

No part of this manual may be reproduced or transmitted in any form or by any means, electronic or mechanical, including photocopying and recording, for any purpose without the written permission of CTI Products, Inc.

This manual describes products that include copyrighted CTI Products, Inc. computer programs in semiconductor memory. CTI Products, Inc. reserves all rights for these programs, including the exclusive right to copy or reproduce the copyrighted computer programs in any form. No copyrighted computer program contained in products described in this manual may be copied, reproduced, decompiled, disassembled, or reversed engineered in any manner without express written permission of CTI Products, Inc. The purchase of products from CTI Products, Inc. shall not be deemed to grant either directly or by implication, estoppel, or otherwise, any license under the copyrights, patents, or patent applications of CTI Products, Inc., except for the normal non-exclusive, royalty fee license to use that arises by operation of law in the sale of the product.

Copyright (c) 1995-2001 CTI Products, Inc. All rights reserved
NCB, NCB/RF, and WON are trademarks of CTI Products, Inc.
Echelon, LON, LONWORKS, LONTALK, LONMARK, and Neuron are U.S. registered trademarks of Echelon Corporation.

Radio Frequency Emissions and Immunity

This equipment generates, uses, and can radiate radio frequency energy and, if not installed and used in accordance with the instruction manual, may cause harmful interference to radio communications. Operation of this equipment in a residential area is likely to cause harmful interference in which case the user will be required to correct the interference at his own expense. Changes or modifications to this unit not expressly approved by the party responsible for compliance could void the user's authority to operate the equipment. Limits specified in the standards listed below are designed to provide reasonable protection against harmful interference when the equipment is operated in a commercial environment.

UNITED STATES: This equipment has been tested and found to comply with the limits for a Class A digital device, pursuant to Part 15 of the FCC Rules.

CANADA: This Class A digital apparatus meets all requirements of the Canadian Interference-Causing Equipment Regulations. Cet appareil numérique de la classe A respecte toutes les exigences du Règlement sur le matériel brouilleur du Canada.

EUROPE: This equipment has been tested and found to conform with the following standards: EN60950, EN50082-1, IEC801-2, IEC801-3, IEC801-4, and EN55022. This equipment complies with the requirements of the following directives: Low Voltage Directive 73/23/EEC, EMC Directive 89/336/EEC, and 93/68/EEC Harmonization of CE Marking.

General RF Transceiver Notice

The RF transceiver provided with the NCB-RF unit may be subject to regulatory agency requirements. See the specific user documentation provided with the RF transceiver for more detail.

TABLE OF CONTENTS

QUICK-START GUIDE	1
1. INTRODUCTION.....	3
WHAT IS AN NCB/RF UNIT?	3
REFERENCE DOCUMENTS.....	5
FRONT PANEL	6
REAR PANEL.....	7
2. SETUP AND OPERATION	8
STEP 1. MOUNTING.....	8
STEP 2. SWITCH SETUP	8
STEP 3. ELECTRICAL CONNECTIONS	10
STEP 4. IMPLEMENTATION IN A NETWORK.....	11
STEP 5. CONTROLLING THE WAN CONNECTION	14
3. NETWORK VARIABLE (NV) CONTROL (EXTERNAL MODEMS ONLY)	15
TYPICAL NV BINDINGS	15
MODEM CONTROLLER OBJECT	15
GLOBAL CONTROL OBJECT.....	16
4. NCB/PLUG CONFIGURATION PLUG-IN (EXTERNAL MODEMS ONLY).....	17
INSTALLATION.....	17
ACCESSING NCB/PLUG.....	18
USAGE	18
APPENDIX.....	21
APPENDIX A. FACTORY DEFAULT CONFIGURATION	21
APPENDIX B. MOUNTING OPTIONS	23
APPENDIX C. CONNECTOR DETAILS	26
APPENDIX D. TROUBLESHOOTING	28
APPENDIX E. SPECIFICATIONS	31
INDEX.....	32

QUICK-START GUIDE

This Quick Start Guide provides a concise series of steps to get a pair of the NCB modules “up and running” quickly so that initial operation may be confirmed.

It is important that all LonWorks devices attached to the “NETWORK” connector of any one NCB module use the same network transceiver. See “LONWORKS NETWORK TRANSCEIVERS” in section “1. INTRODUCTION”.

In the following steps, identify the two units as “NCB Unit 1” and “NCB Unit 2”.

Switch Settings

- If you are using the **Short Range** radio (model 200-DTG) or **Mid Range** radio (model 210), set the NCB unit switches as follows:
BAUD 1 : 6 BAUD 2 : 0 MODE 1 : A MODE 2 : A
OPTION B Switches 1 through 4 : UP
OPTION A Switches 1 through 4 and 6 through 8 : UP
OPTION A Switch 5 : DOWN
- If you are using the **Long Range** radio (LongRanger 2000 -- ISM900-1HD or ISM2.4-1HD), set the NCB unit switches as follows:
BAUD 1 : 7 BAUD 2 : 0 MODE 1 : B MODE 2 : B
OPTION B Switch 1 : DOWN on NCB Unit 1 and UP on NCB Unit 2
OPTION B Switches 2 through 4 : UP
OPTION A Switches 1 through 4 and 6 through 8 : UP
OPTION A Switch 5 : DOWN
- If you are using the **Long Range** radio (LongRanger 2020 -- ISM900-1C64 or ISM2.4-1C64), set the NCB unit switches as follows:
BAUD 1 : 7 BAUD 2 : 0 MODE 1 : 7 MODE 2 : 7
OPTION B Switch 1 : DOWN on NCB Unit 1 and UP on NCB Unit 2
OPTION B Switches 2 through 4 : UP
OPTION A Switches 1 through 4 and 6 through 8 : UP
OPTION A Switch 5 : DOWN

Module Connection

- Connect LonWorks network devices to the “NETWORK” connectors of each NCB unit (both RJ-45s and the terminal strip are in parallel). If using the RJ-45 connector(s), connect to pins 1 & 2 (the right-most two pins) and use caution, as other pins on these connectors carry DC power.
 - Connect the DB25 connector on the radio to the “PORT 1” connector on the rear of the NCB unit using the cable supplied. Connect the appropriate antenna if using the **Mid Range** or **Long Range** radio.
- Connect power to the radios, and to the NCB units via the front panel “DC IN” connector. The units can be powered-up in any sequence.
- Both NCB Unit “ERR” LEDs will begin to flash

NOTE: It is normal for the NCB Unit “ERR” LED to flash quickly for up to 30 seconds after power-up or reset of a fully configured and connected NCB-RF module. This indicates that any external radios configured for use are in process of initializing. A problem is indicated only if the ERR LED locks on or continues to flash for more than 30 seconds after power-up or reset.

Once the “ERR” LEDs on both NCB units stop flashing, the system is ready for use. On the *Long Range* radio, the “Rx” and “Tx” LEDs will flicker very quickly on both radios. Any LonTalk packets entering one NCB unit will exit the other and vice-versa.

1. INTRODUCTION

WHAT IS AN NCB/RF UNIT?

The Network Combiner NCB/EM™ Module is a wide-area router with one or two external Wireless RF Transceivers used for LONWORKS® networks. The NCB/RF unit is used in pairs to connect LONWORKS® networks real-time, without interconnecting cables. The communication channel spanning the distance between local networks can be any wireless channel in the 900 MHz or 2.4 GHz bands. Data transfer between distant networks via an NCB module pair is "live", delayed only by the transit time through the routers and wireless channels.

Read this section to learn the general function and capabilities of an NCB Router

The NCB module uses router technology so that no custom coding or additional hardware is necessary to seamlessly connect multiple networks across very large distances. The NCB module is self-contained, easily configured with standard network management tools, and requires no custom programming or coding changes in system nodes.

Basic Application

A basic application of the NCB module is where two multi-node LonWorks networks, separated by a distance beyond the reach of conventional wired media, need to be interconnected, as in Figure 1. This distance could be across a large building, business campus, city, etc. Using the NCB module, this interconnection is accomplished using one NCB module local to each network site and a single voice-grade telephone circuit connecting the two NCB modules. Additional networks can be added to this unified network by simply adding an NCB module pair per network.

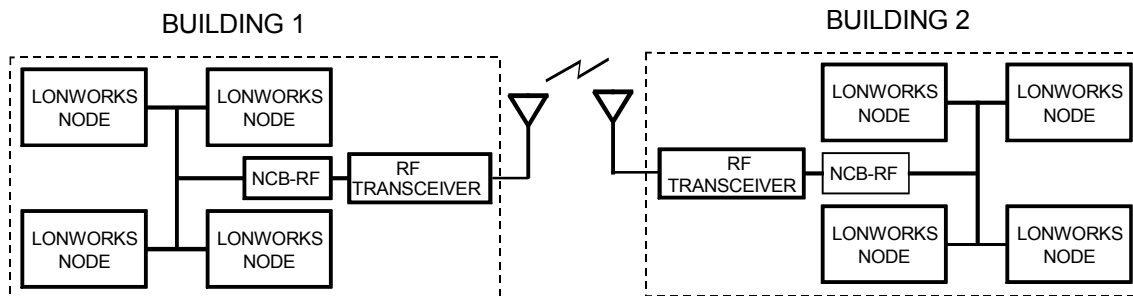

Figure 1 Networks in two buildings connected with NCB modules

LonWorks Network Transceivers

The local LONWORKS networks at different sites do not need to use the same network transceiver type. For example, an FTT-10A network, a TPT/XF-78 network, and a PLT-22 network can all be interconnected by using pairs of NCB modules with network transceivers matching the local network at each site.

NCB units are available with an option for LONWORKS network transceiver type. The ordering code on the rear of the NCB lists the installed options. This ordering code is of the form: **NCB/RF-Txxx-xx**, where 'T' indicates the transceiver type.

The following LONWORKS network transceiver options are available:

A = FTT-10A	K = SMX RS485
B = TPT/XF-78	M = SMX PL22
C = TPT/XF-1250	X = None (SMX ready)

External Serial Ports

“PORT 1” and “PORT 2” are standard asynchronous serial ports with individually configurable baud rates from 1200 to 115200 bps. A radio can be connected to each port. “PORT 1” and “PORT 2” pinouts allow direct connection to a radio via a standard 9 pin to 25 pin cable.

Data Flow

There are three sources of message packets within the NCB module. The first source is the LONWORKS NETWORK connector on the front of the unit. The second is the “PORT” connectors on the rear of the unit. The third source is the Control Neuron® Processor. Message packets originating from any of these sources are sent to the other two. This message packet flow is shown in the block diagram of Figure 2.

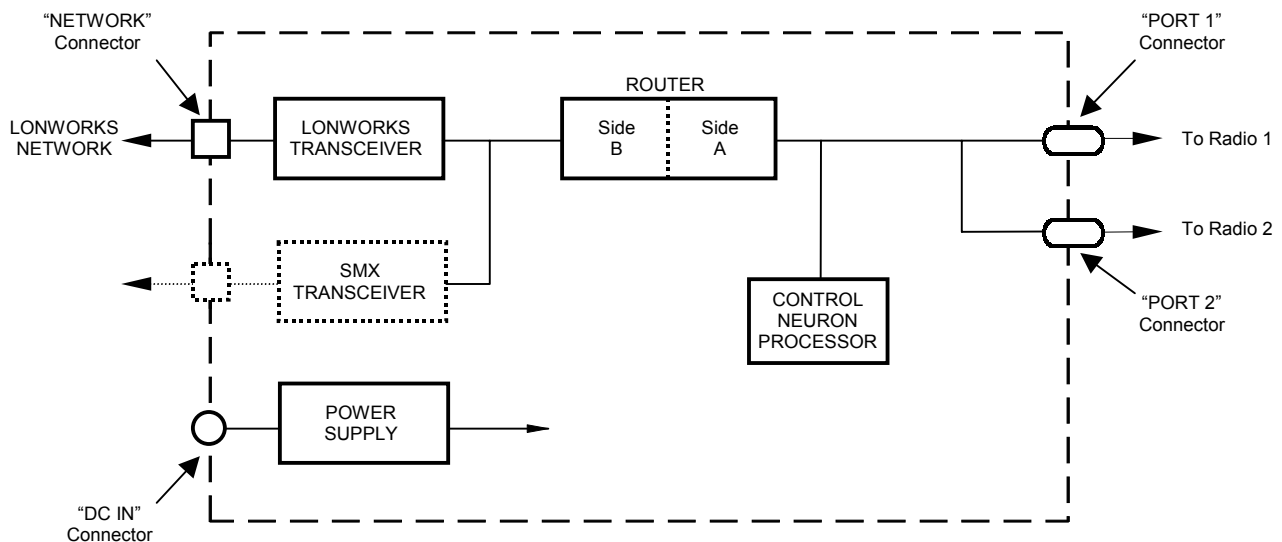

Figure 2 NCB Network Combiner Block Diagram

- The “NETWORK” connector attaches to the local LONWORKS network using a compatible transceiver internal to the NCB module and is associated with *Side B* of the internal router.
- The “PORT” connector attaches to the radio as the link to the NCB unit at the other network site and is associated with *Side A* of the internal router.
- The Control Neuron® Processor allows network management messages to be sent to the NCB module for connection control and status monitoring and is associated with *Side A* of the internal router.

Router Function

The router contained in each NCB module may be configured as a repeater, bridge, or configured router. The easiest configuration is as a repeater, where all messages which enter the NCB module (via any of the three data sources described above) are simply passed to the other two sources, regardless of the domain, subnet/node, or group destination address. A bridge only passes messages that match one of the two domain IDs configured on the router. A configured router only passes messages that match a domain ID as well as a set of subnet or group

numbers. The proper choice of router mode depends on desired simplicity of installation versus required system performance.

REFERENCE DOCUMENTS

The following additional information is available from the sources indicated.

Document	Source	Reference Number
Message Buffer Configuration	CD ROM or www.ctiproducts.com	Technical Note TN010
Using Explicit Messages to Configure and Monitor Dialing Parameters of an NCB	CD ROM or www.ctiproducts.com	Technical Note TN022
Using NCBCON to Configure and Monitor Dialing Parameters of an NCB	CD ROM or www.ctiproducts.com	Technical Note TN023
Setting the PCNSS Card to Network Interface Mode	CD ROM or www.ctiproducts.com	Technical Note TN024
SMX Transceiver Installation	CD ROM or www.ctiproducts.com	Technical Note TN025
NCB Installation with Network Management Tools	CD ROM or www.ctiproducts.com	Technical Note TN026
Short Range Radio-Modem Alignment Procedure	CD ROM or www.ctiproducts.com	Technical Note TN030
LonWorks Router User's Guide	Echelon	078-0018-01B

FRONT PANEL

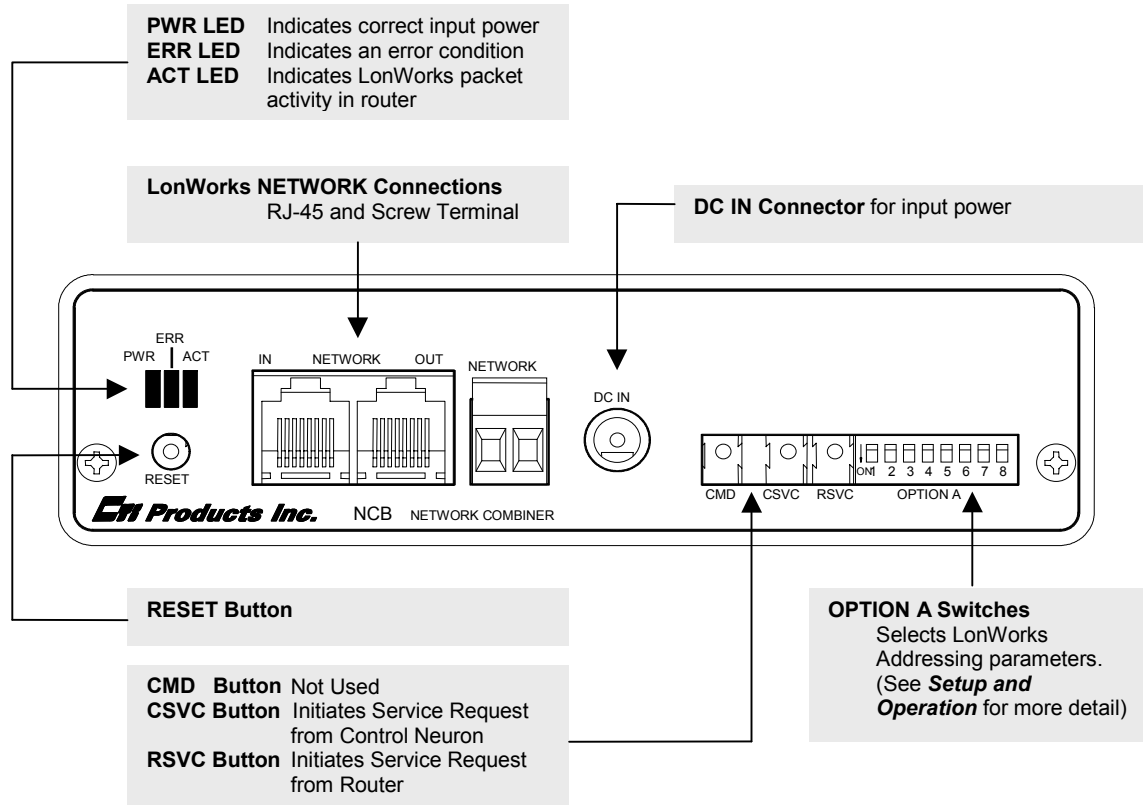

Figure 3 NCB Front Panel

Front Panel Indicators and Buttons

PWR LED (Green) - Indicates condition of DC input power or a “Wink” command.

- **Always On:** Correct DC input power is present.
- **Flashing Continuously:** DC input to module is below minimum required voltage.
- **Flashes for 2 Seconds:** A “Wink” network management command has been sent to the Control Neuron Processor.

ERR LED (Red) – Indicates a possible error condition.

- **Always On:** A diagnostic error has been detected. Press the “RESET” button. If the “ERR” LED now stays off, the EEPROM contained invalid data and has been reinitialized. Any non-volatile information must be re-entered by using the NCB/Plug plug-in or the DOS NCBCON program. If the LED stays on solid, a hardware problem is indicated. Contact technical support for assistance.
- **Slow Flash:** (once per second) LONWORKS configuration information is insufficient. Using a Network Management Tool, re-commission the internal router nodes (and optionally, the Control Neuron Processor node).
- **Quick Flash:** (twice per second) A serial port configured for use (“BAUD” switch set to a value that is not ‘0’) does not detect an attached radio or is in the process of initializing it. In Ring Mode, this could also indicate that duplicate Unit Numbers have been detected in the Ring.

ACT LED (Yellow) - Indicates a packet has been passed by the NCB router.

REAR PANEL

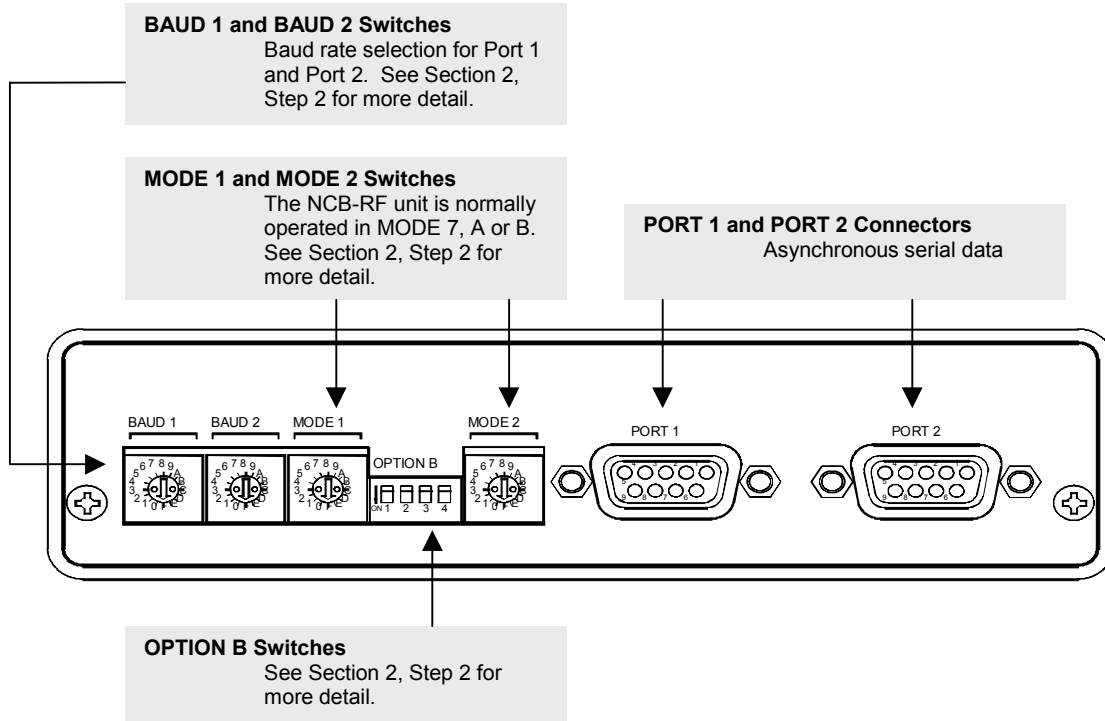

Figure 4 NCB Rear Panel

2. SETUP AND OPERATION

STEP 1. MOUNTING

Non-slip rubber feet are included on all NCB modules to allow them to conveniently rest on any horizontal surface. Four 6-32 threaded holes are also available on the bottom of the module to allow bolting of the module in any convenient orientation. **WARNING: Care should be taken to limit protrusion of the screw into the module to no more than 0.125 inch from the module bottom surface!**

Follow the steps in this section to setup an NCB Router for the first time

Mounting kits are available as options to allow wall or rack (19" EIA) mounting of the NCB module.

See Appendix B for Mounting Option details.

When wall or rack mounting the NCB, a suitable safety and protective earth ground should be provided to the metal enclosure. The protective earth ground provides a path to ground for electrostatic discharge (ESD) energy. This connection is most conveniently made directly to the wall mount bracket or rack plate.

STEP 2. SWITCH SETUP

OPTION A Switches

OPTION A switches set the **LONWORKS addressing** parameters (switches 5 and 6). Leave the unused switches in the **UP** position. The position of the OPTION A switches are read by the NCB at module power-up or after pressing the "RESET" button on the front panel.

1. Not Used		
2. Not Used		
3. Not Used		
4. Not Used		
5. Control Neuron Addressing Method.....	UP	DOWN
6. Control Neuron Hardware Subnet/Node	Hardware 255/2	Network Management Tool 255/1
7. Not Used		
8. Not Used		

Setting the LONWORKS Addressing Parameters (Switches 5 and 6)

Switches 5 and 6 provide a simple (but very limited) method of setting the LONWORKS domain/subnet/node address of the internal Control Neuron Processor. This method is useful for systems with two NCB modules, but does not provide enough flexibility for larger systems. (Standard Network Management Tools are a much better choice.) For more information on setting this address, see "STEP 4. IMPLEMENTATION IN A NETWORK" for a tutorial on network management tools.

- If OPTION A Switch 5 is **UP**, Switch 6 determines a static subnet/node address for the Control Neuron Processor: Switch 6 **DOWN** fixes the Control Neuron Processor subnet/node address at 255/1 in the zero-length domain, while Switch 6 **UP** fixes the subnet/node address at 255/2 in the zero-length domain. This setting allows for a quick evaluation of the NCB modules, requiring minimal user setup.

- If OPTION A Switch 5 is **DOWN**, dynamic determination of the domain/subnet/node number by a Network Management Tool is allowed.

OPTION B Switches

For proper setting of OPTION B Switches, refer to the “Insert Document” for the specific radio being used.

BAUD Switches

“BAUD 1” and “BAUD 2” switches correspond to “PORT 1” and “PORT 2” connectors and allow either disabling the port for use or enabling it at a specific baud rate. For proper setting of BAUD Switches, refer to the “Insert Document” for the specific radio being used.

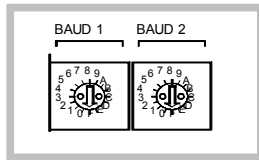

Position	Function/Baud Rate
0	Disable Port
1	1200 Baud
2	2400
3	4800
4	9600
5	19200
6	38400
7	57600
8	115200

NOTE: Set the “BAUDn” switch to 0 if the respective port will not be used. This is important, as the front panel “ERR” LED will flash continuously if a serial port “BAUD” switch is non-zero and no radio is connected.

Mode Switches

For proper setting of MODE Switches, refer to the “Insert Document” for the specific radio being used.

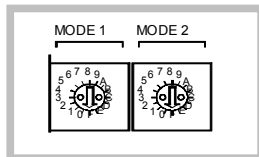

STEP 3. ELECTRICAL CONNECTIONS

LONWORKS Network Connection

The local LONWORKS network must be attached to the NCB module via the “NETWORK” connector following standard Echelon guidelines as to cable type, cable length, and termination appropriate for the selected transceiver.

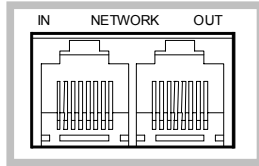

The dual RJ-45 “NETWORK” connector allows a daisy-chained network connection method, as the network pins of the two RJ-45 connector are directly paralleled. Note that other pins on the RJ-45 are connected to circuit ground and DC power.

See Appendix C
for Connector
Details

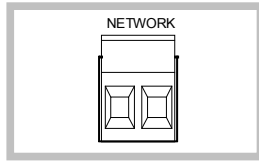

The 2 pin removable terminal strip is wired in parallel with the network connections on the dual RJ-45 connector.

NOTE: If your NCB module was purchased without a LONWORKS transceiver (SMX-ready), refer to Technical Note TN025 to install your SMX transceiver.

Radio Connection

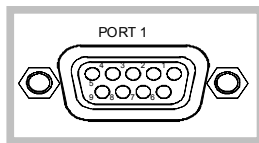

Connect the external radio(s) to “PORT 1” (and “PORT 2” if two radios are being used) on the rear of the NCB unit using the cable(s) supplied with the radio(s) (this is a standard 9 pin to 25 pin modem cable). Provide power to the external radio(s) per the manufacturer requirements.

See Appendix C
for pinouts and
cable diagrams.

NOTE: Set the **BAUD 1**, **BAUD 2**, **MODE 1**, **MODE 2**, and **OPTION B** switches according to information in section “2. SETUP AND OPERATION”, “STEP 2. SWITCH SETUP” **BEFORE** powering up the NCB module.

DC Power Connection

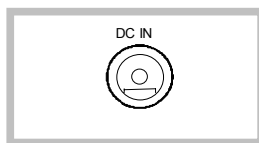

DC power must be attached to the NCB module via the **DC IN** connector (see “APPENDIX C. CONNECTOR DETAILS”). **Apply DC power to the NCB module only after all other connections have been made.** A wall plug-in style power supply designed for the NCB module is an available option.

STEP 4. IMPLEMENTATION IN A NETWORK

Will a Network Management Tool Be Used?

?

- If NO, and the NCB will be used with its factory default settings (Repeater Mode), skip the rest of this section. The NCB is ready to function in a network.
- If NO, and the DOS NCBCON program will be used to access and configure the Control Neuron Processor, then see Technical Note TN023.
- If YES, and LonMaker For Windows will be used, **be certain that 'OPTION A Switch 5 is in the DOWN position**, and see **Commissioning the NCB with LonMaker for Windows** later in this section.
- If YES, and another Network Management Tool will be used, **be certain that 'OPTION A Switch 5 is in the DOWN position**, then see Technical Note TN026.

Tutorial . . .

Why is a Network Management Tool needed?

Factory Default Settings

An NCB could be placed in a network using the configuration as it was shipped from the factory (Repeater Mode, fixed Subnet/Node address). All messages would simply be passed through the NCB. This may suffice for small networks where channel bandwidth and message timing issues are of no concern.

Use of a Network Management Tool

If a larger network is planned, and channel bandwidth limitations require segmentation of message traffic, then a Network Management Tool should be used to perform some or all of the following functions:

- Assign unique addresses to each NCB Router and Control Neuron
- Configure domain address tables in routers
- Optimally set Transaction Timers based on Channel Delays
- Configure forwarding tables in routers for traffic segmentation

Commissioning the NCB with LonMaker for Windows

Commissioning *each* NCB *in a network* with LonMaker for Windows involves commissioning two different network devices, both contained in the single NCB enclosure: a standard **LONWORKS router**, and the **control neuron**.

Since the standard LONWORKS router portion of an NCB router interfaces a LONWORKS channel to a WAN channel, it requires connection to two channels on the LonMaker drawing. A standard LONWORKS channel will be connected to **Side B** of the router shape, and a **CUSTOM** WAN Channel will be connected to **Side A** of the router shape.

Commissioning the NCB control neuron requires that the .XIF file be available. The simplest way to do this is to install the NCB/Plug Plug-In, as this process copies the required .XIF file to the proper directory.

Installing NCB/Plug Plug-in

- A) Install the NCB/Plug plug-in on your PC:
- Insert the NCB/Plug CD into your CD-ROM drive.
 - Click the Windows Start button, choose Run..., click **Browse...**, select the Setup application on the NCB/Plug CD, and click **Open**.
 - Follow the instructions displayed by the Setup application.
 - Restart your computer when the Setup application is complete.

NOTE: Two External Interface Files (.XIF) are automatically transferred to the hard drive when NCB/Plug plug-in is installed. NCBTLC30.XIF should be used for the Control Neuron Processor of an NCB of Version 3. NCBTLC20.XIF should be used for the Control Neuron Processor of an NCB of Version 2.

- B) Register NCB/Plug with LonMaker for Windows:
- Click the Windows Start button, choose Programs, then NCBPlug, and click on NCBPlug.
 - Click **Register Plug-In**.
 - Click **Exit**.
- C) Register NCB/Plug with the desired LonMaker for Windows network:
- Start LonMaker for Windows and open the desired network (be sure to checkmark the “Show all Network Option Screens” box). When the “Plug-In Registration” window within the Network Wizard appears, highlight the “NCB_Plug” under “To Be Registered” and click Finish.

After installing and registering the NCB/Plug Plug-In, commission *the “local NCB” (the one whose “NETWORK” port is connected to the NSI attached to LonMaker for Windows)* using the following steps:

Commissioning the NCB

- A) Add a CUSTOM channel to the network drawing (this will be the WAN channel):
- Drag the **Channel** shape to the drawing. The “*Channel Definition*” window will be displayed.
 - Specify an appropriate Channel Name.
 - In the “Transceiver Type” field, click the down arrow and select **CUSTOM**.
 - In the “Delay” section, choose “Specify”, and enter a value of 120ms.
 - Enter a Channel Description, if desired.
 - Click **OK** to continue.
- B) Add the standard LONWORKS router portion of the NCB to the network drawing:
- Drag the **Router** shape to the drawing. The “*New Router Wizard*” window will be displayed.
 - Specify the desired router name.
 - Click **NEXT** to continue.
 - In the “Channel A” **Name** field, choose the custom channel created in *Step a*.
 - In the “Channel B” **Name** field, choose the standard LONWORKS channel connected to the “NETWORK” connector on the NCB.
 - Click **NEXT** to continue.
 - Specify a Location string and Description, if desired. “Ping Interval” can be set as desired, however should be set to “never” for remote NCB routers which are not connected full-time (for example, those connected via dial-up telephone lines).
 - Click **NEXT** to continue.
 - Specify desired advanced router properties. *Router Type : Configured* is recommended.
 - Click **FINISH** to complete the “*New Router Wizard*”.
- C) Add the Control Neuron Processor to the network drawing:
- Drag the **Device** shape to the drawing. The “*New Device Wizard*” window will be displayed.
 - Specify the desired Device Name.
 - Click **NEXT** to continue.
 - In the “External Interface Definition” section, choose ‘Existing Template’, click the down arrow and choose the appropriate template as follows: NCBTLC30.XIF should be used for the Control

Neuron Processor of an NCB of Version 3, NCBTLC20.XIF should be used for the Control Neuron Processor of an NCB of Version 2.

- Click **NEXT** to continue.
 - In the “Channel: Name:” section, choose the custom channel connected to *Side A* of the router that was created in *Step a*.
 - Click **NEXT** to continue
 - Specify a Location string and Description, if desired. “Ping Interval” can be set as desired, however should be set to “never” for remote NCBs which are not connected full-time (for example, those connected via dial-up telephone lines).
 - Click **FINISH** to complete the “*New Device Wizard*”.
- D) Commission the LONWORKS router:
- Right-click on the router shape added in *step b*.
 - Click on the *Commission* function
 - Select the *Online* state.
 - Click **FINISH** to commission the router.
- E) Commission the Control Neuron:
- Right-click on the Control Neuron device shape added in *step c*.
 - Click on the *Commission* function
 - Select the *Online* state and *Current Values in Database* for *Source of Configuration Property Values*.
 - Click **FINISH** to commission the Control Neuron.

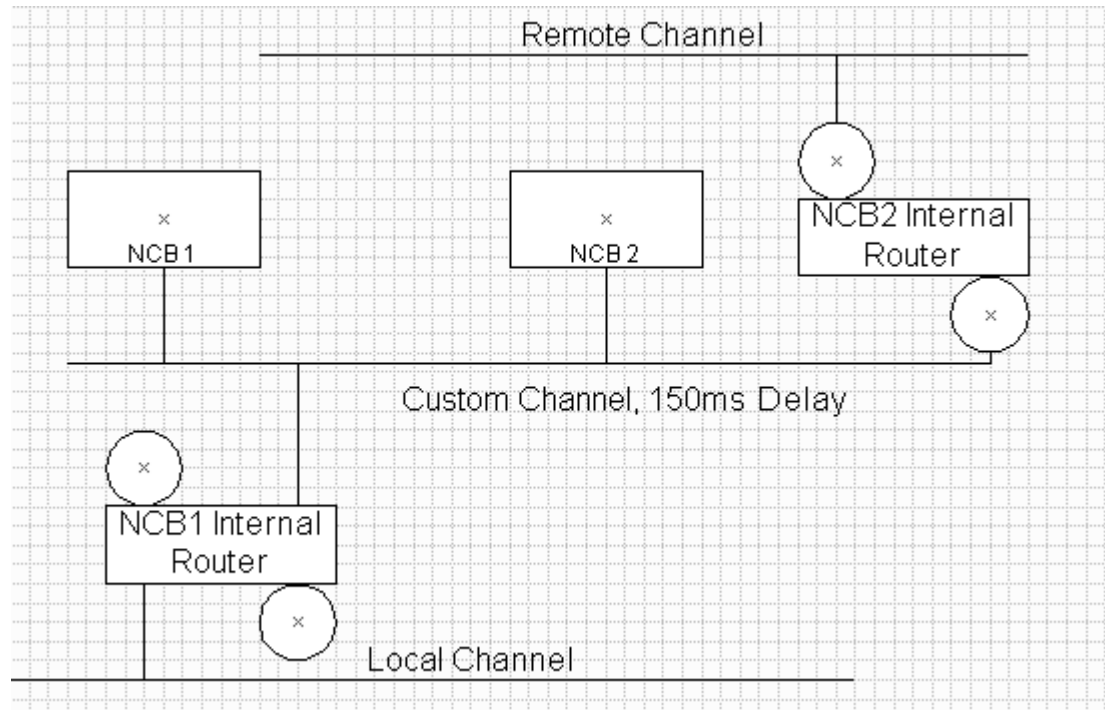

Figure 5--LonMaker NCB Diagram

STEP 5. CONTROLLING THE WAN CONNECTION

At this point, the “local” NCB (the one connected to the LonMaker for Windows NSI) has been configured and fully commissioned for use. This last step involves making a connection to the “remote” NCB via the wireless channel. Normally when using the NCB-RF, since the wireless channel will allow immediate communication with the remote NCB, no control of the WAN connection is required. Message packets will flow between the local and remote NCBs across the wireless channel. To commission the remote NCB router, repeat *B* and *D* of [Commissioning the Router](#) in *Step 4* above.

Since controlling the WAN connection is normally not required when using the NCB-RF, the remainder of this step can be skipped, and the NCB-RF is ready for use. However, the following information may be useful for requesting a soft reboot or product name.

Network Variables and the NCB/Plug Plug-In

Tutorial . . .

Network Variables

Network Variable Bindings allow a device to send and receive messages to and from other devices on the network. All configuration and status commands sent to the NCB module are carried on the LonTalk network in the form of Network Variables bound to the Control Neuron Processor inside the NCB module. The following functions are available if Network Variable bindings are made:

- Request a soft reboot of NCB
- Request Product Name Output from NCB

Will bindings be made to any Network Variables?

?

- If NO, you may wish to use the NCB/Plug Plug-In (See ‘**Tutorial: NCB/Plug**’ above).
- If YES, see SECTION 3, [NETWORK VARIABLE \(NV\) CONTROL](#). You may also wish to use the NCB/Plug plug-in (See ‘**Tutorial: NCB/Plug**’ above).

Tutorial . . .

NCB/Plug

LNS plug-ins are applications that can be started from within an LNS application (such as the LonMaker tool) to perform a specialized task. The NCB/Plug plug-In implements configuration and query commands for the NCB. The NCB/Plug plug-In and Network Variables can be used simultaneously. The following functions are available if the NCB/Plug plug-In is installed:

- Request a soft reboot of NCB

Will NCB/Plug be used?

?

- If NO, you may wish to make Network Variable bindings (See ‘**Tutorial: Network Variables**’ above).
- If YES, see SECTION 4, [NCB/PLUG](#). You may also wish to make Network Variable bindings (See ‘**Tutorial: Network Variables**’ above).

3. NETWORK VARIABLE (NV) CONTROL (External Modems Only)

Skip this section unless you have an external telephone modem connected to one of the ports.

This section contains details of Network Variables and Bindings used in Dial-Up applications.

NCB/RF units do not use Network Variables unless they have an external telephone modem connected to one of the ports.

TYPICAL NV BINDINGS

All commands sent to the NCB module are carried on the LonTalk network in the form of Network Variables bound to the Control Neuron processor inside the NCB module (connected to *Side A* of the internal router). This section details the **Functional Blocks** (objects) and the network variables of each. The Modem Controller Objects and Directory Objects will be functional only if a modem is attached to the “PORT” connector.

An Internal Modem Controller Object and two External Modem Controller Objects are included which meets the LonMark “Modem Controller” Functional Profile. In addition, two Directory Objects are included which meet the LONMARK “Directory” Functional Profile. Finally, a Global Object is included to help perform miscellaneous tasks.

MODEM CONTROLLER OBJECT

The Modem Controller Object is used to control the functions of the NCB Module’s data modem. These functions include configuration, connection control, and connection status. Two Modem Controller Objects are available, depending on the NCB model being used. ‘Internal Modem’ is for use with the NCB-IM. ‘External Modem1’ and ‘External Modem 2’ are for use with the NCB-EM and NCB-IS. The Modem Controller Objects have identical network variable inputs and outputs.

Connect Status (Output)

C Language Syntax

```
network output SNVT_telcom nvoCnctStat1;
network output SNVT_telcom nvoCnctStat2;
```

Usage

- This output network variable provides the current state of the modem connection process.

Valid Range

Value	Output String	Description
9	TEL_TALKING	Modem connected and online with distant modem, ready to send data
20	TEL_ERROR	Modem initializing, not present, or port disabled

When Transmitted

The output is updated upon each change in modem connection state.

Update Rate

The output is updated only once per change in modem connection state.

GLOBAL CONTROL OBJECT

The following network variables pertain to the entire NCB, and not just to a single Modem Controller object or Directory Object.

Product Name (Output)**C Language Syntax**

```
network output SNVT_str_asc nvoProductName;
```

Usage

This output network variable contains an ASCII string identifying the product.

When Transmitted

Unsolicited at power-up and reset, or when polled.

4. NCB/PLUG CONFIGURATION PLUG-IN (External Modems Only)

Skip this section unless you have an external telephone modem connected to one of the ports.

This section contains details of the NCB/Plug Configuration Plug-In used for setting dialing parameters in Dial-Up applications.

NCB/RF units do not require the use of the NCB/Plug Plug-In unless they have an external telephone modem connected to one of the ports.

LNS plug-ins are applications that can be started from within an LNS application (such as LonMaker for Windows) to perform a specialized task. The NCB/Plug plug-in implements configuration and query commands for the NCB. The NCB/Plug plug-in and Network Variables can be used simultaneously. The following functions are available if NCB/Plug is installed:

- Pulse router service pin
- Request a soft reboot of NCB

The following function (for models NCB-EM, NCB-IS, and NCB-AY) will also be displayed, but will have no effect when using NCB-IM and NCB-RF models:

- Configure Ring Mode parameters

The following functions (for models NCB-IM, NCB-EM, and NCB-IS) will also be displayed, but will have no effect when using the NCB-RF models:

- Send a dial string to a modem
- Send a 'Call Cancel' command to a modem
- Configure the NCB Directory
- A window displays 'Connect Status'
- Select Dial Mode (Manual or Perpetual)
- Select Auto Answer Enabled Mode

INSTALLATION

NOTE: If you have already performed these steps as detailed in Section 2 "Setup and Operation", they do NOT need to be repeated here. In this case, skip directly to "Accessing NCB/Plug" below.

1. Install the NCB/Plug plug-in on your PC:
 - a) Insert the NCB/Plug CD into your CD-ROM drive.
 - b) Click the Windows Start button, choose Run..., click **Browse...**, select the Setup application on the NCB/Plug CD, and click **Open**.
 - c) Follow the instructions displayed by the Setup application.
 - d) Restart your computer when the Setup application is complete.
2. Register NCB/Plug with LonMaker for Windows:
 - a) Click the Windows Start button, choose Programs, then NCBPlug, and click on NCBPlug.
 - b) Click **Register Plug-In**.
 - c) Click **Exit**.
3. Register NCB/Plug with the desired LonMaker for Windows network:

- a) Start LonMaker for Windows and open the desired network (be sure to checkmark the “Show all Network Option Screens” box). When the “Plug-In Registration” window within the Network Wizard appears, highlight the “NCB_Plug” under “To Be Registered” and click Finish.

Two *External Interface Files* (.XIF) are automatically transferred to the hard drive when NCB/Plug plug-in is installed. NCBTLC30.XIF should be used for the Control Neuron Processor of an NCB of Version 3. NCBTLC20.XIF should be used for the Control Neuron Processor of an NCB of Version 2.

ACCESSING NCB/PLUG

- a) Bring NCB/Plug to the desktop:
- b) Right click on the Control Neuron Functional Block to be configured (Modem, Directory, Globals). In the drop-down list, click “Configure”. The Plug-In will appear as shown here.
- c) Alternatively, right click on the Control Neuron Processor device shape. In the drop-down list, click “Plug-Ins...”, and select NCB/Plug. Click **OK** to continue. The Plug-In will appear as shown here.

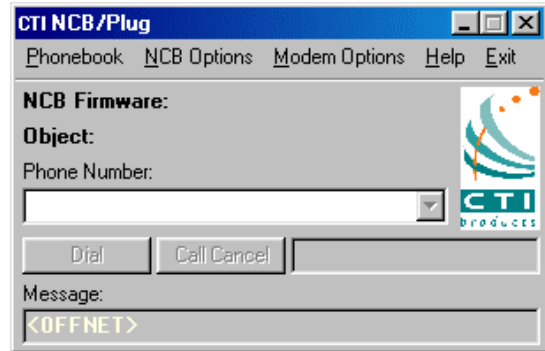

USAGE

Starting NCB/Plug from a Modem or Global Functional block shows the main NCB/Plug window from which both modem and Directory configurations and operations may be performed. Starting NCB/Plug from a Directory functional block shows only the Directory window from which only Directory information may be configured or printed.

If LonMaker is currently in “Offnet” mode, only the configuration functions of NCB/Plug (including Directory and certain Modem and NCB Options) will be available, and “<OFFNET>” will appear in the Message Box.

If the Control Neuron device being configured is not currently attached to the network, NCB/Plug will display a “Connection Error”.

- “Yes” may be clicked to retry communication with the device after reconnecting it.
- “No” may be clicked to ignore the error and enter NCB/Plug to perform configuration functions only. In this case, “No response from <device name>” will be shown in the Message box.
- “Cancel” may be clicked to abort the load of NCB/Plug.

Manual Dialing

A dial string can be entered directly into the Phone Number box of the main NCB/Plug window. The **Dial** button can then be used to initiate a call. The **Call Cancel** button can be used to terminate a call. Connect Strings are displayed in the Message window. Connect Status is also displayed.

Directory Menu Item

The **Phonebook** menu item accesses the Directory and is used to edit a list of 16 telephone numbers (dial strings). A **Description** field is available for each of the 16 **Number** entries. Any entry in the Directory can be accessed for dialing by using the pull-down button of the Phone Number box on the main NCB/Plug window. File -> Print to File pastes the current Directory information to Windows Notepad from where it may be saved, printed, pasted, etc.

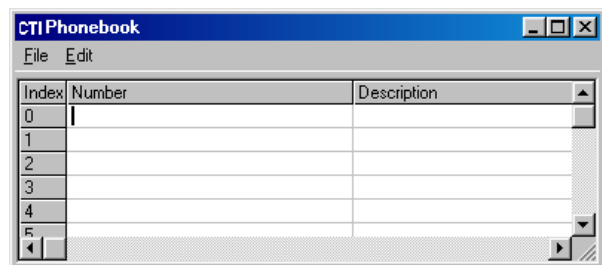

NCB Options Menu Item

The **NCB Options** menu item provides access to the following functions:

Pulse Router Service Pin

This is equivalent to pressing the “RSVC” button on the NCB Unit's front panel.

Soft Reboot

This is equivalent to pressing the “RESET” button on the NCB Unit's front panel.

Ring Mode Parameters

Ring Mode Parameters are not used on the NCB/RF. Do not enable these parameters. **Modem Options Menu Item**

Auto Answer (Dial-Up only)

This option allows enabling or disabling the Auto Answer function in Dial-up mode. A check next to the menu item indicates Auto Answer is currently *enabled*. Be careful when disabling Auto Answer mode on a remote NCB, as once connection with this unit is broken, it will no longer automatically answer an incoming call. To re-enable Auto Answer mode, proceed as follows:

- Press and hold the “CMD” button on the remote NCB
- Press and release the “RESET” button on the remote NCB.
- Wait until the “PWR” LED begins to flash on the remote NCB, then release the “CMD” button.

These steps will temporarily enable Auto Answer mode for the remote NCB for one incoming call. Use NCB/Plug, NCBCON, or explicit messages to re-enable Auto Answer mode for future connections.

Mute Input Audio

This option has no effect in an NCB/RF Unit.

Dial Mode (Dial-Up only)

Manual or *Perpetual* dialing modes are supported. If the modem is currently connected to another NCB, the Dial Mode will not change until the current call is cancelled.

Connection Statistics

The Connection Statistics window appears to the right.

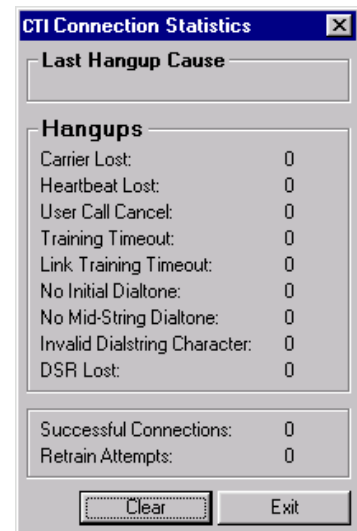

APPENDIX

APPENDIX A. FACTORY DEFAULT CONFIGURATION

Control Neuron Processor

Restoring Factory Default Parameters

Should the Control Neuron Processor communication parameters be overwritten incorrectly by a network management tool, they can be restored as follows:

- Press the “RESET” button on the front of the NCB unit
- After the “ERR” LED goes off, press the “RESET” button a second time.

The Control Neuron communication parameters are now restored to factory defaults.

Router

The router portion of the NCB module may be configured for various operational characteristics. The factory default configuration is as a **repeater**, where all messages entering the NCB module (via any of the three data ports described in section “1. INTRODUCTION” are simply passed through, regardless of the domain, subnet/node, or group destination address of the message. Other algorithms, as described in section “1. INTRODUCTION”, can be selected using standard LONWORKS Network Management Tools such as the LonBuilder, LonMaker, or LNS.

The communication parameters for sides A and B of the router are forced to their proper settings via NCB hardware and need not be set (nor can they be changed) by the Network Management Tool.

Further details of router operation and configuration are contained in the Echelon document entitled “LONWORKS Router User's Guide”, Echelon part number 078-0018-01B.

Address Assignments

The router inside the NCB module contains two Neuron chips, each with its' own subnet/node number assignment. The default factory configuration of the router Neurons is subnet 255 node 126 and subnet 255 node 127. If any other nodes in the system to which the NCB is connected are configured with either of these subnet/node addresses, the router should be reconfigured to different addresses using any standard Network Management Tool.

Buffer Configuration

The NCB module utilizes buffers to store incoming messages and route them out to other ports. The configuration of these buffers (the number of bytes in each buffer as well as the number of buffers) determine the maximum size message that can be passed and the performance of the NCB module under conditions of bursty traffic. In the standard configuration, the NCB router restricts the maximum size message that can be passed to a length of 40 to 50 bytes of user data, depending on the addressing overhead in the packet.

Technical Note TN010 covers the topic of buffers and buffer sizes in detail and should be referenced if messages to be passed through the NCB module could exceed the maximum default size.

Querying, Defaulting, and Unconfiguring Router Configuration using SETRTR.EXE

The SETRTR.EXE DOS utility provided with each NCB can be used to query the router for its current configuration, force the router to certain default states, or force the router to *unconfigured* mode. If the router will be installed with the *configured* router algorithm, it is highly recommended that the router module is set to

unconfigured mode before being installed into the system (this step is mandatory if redundant routers are to be configured).

Refer to Technical Note TN025 for more information on configuration of the router with standard network management tools such as LonBuilder, LonMaker, LNS, and others.

The SETRTR program requires a network interface to be connected to the personal computer. This network interface can be an Echelon SLTA, PCLTA, PCNSS, or any other device conforming to Echelon network interface standards. Network interface driver software must be loaded in the personal computer and configured with a device name (typically "LONn" where n is a number). Documentation provided with the network interface device details how to install the unit and driver software. The network interface device must contain a network transceiver compatible with the network transceiver in the NCB module to be controlled.

NOTE: *If you are using the PCLTA card as a network interface and the NCB is not performing the commands as expected, the PCNSS has probably not been configured for network interface mode. See Technical Note TN024 for information on configuring the PCNSS card into network interface mode.*

After the network interface and its software driver are properly configured on the personal computer, connect its' network port to the front panel "NETWORK" connector on the NCB.

Querying an NCB Unit's Router for its Current Configuration

Start the SETRTR program with the following command line:

```
SETRTR [-ddevicename] -L <cr>
```

where *devicename* is the name assigned to the network interface on the command line of the device driver (typically "LON1" or "LON2"). If this parameter is omitted, the default name of LON1 is used.

The -L parameter instructs SETRTR to List the current configuration of the router module.

After the signon message appears, press the "RSVC" button on the front of the connected NCB module. SETRTR will report the current router configuration to the screen.

Returning an NCB Unit's Router to Factory Default Configuration

Start the SETRTR program with the following command line:

```
SETRTR [-ddevicename] -F <cr>
```

where *devicename* is the name assigned to the network interface on the command line of the device driver (typically "LON1" or "LON2"). If this parameter is omitted, the default name of LON1 is used.

The -F parameter instructs SETRTR to set the RTR-10 to full Factory defaults, including router algorithm, domain tables, and buffer settings.

After the signon message appears, press the "RSVC" button on the front of the connected NCB module. SETRTR will send the required messages to the router and exit. Press the "RESET" button on the front of the NCB module to complete the reconfiguration.

Setting an NCB Unit's Router to Unconfigured Mode

Start the SETRTR program with the following command line:

```
SETRTR [-ddevicename] -U <cr>
```

The -U parameter instructs SETRTR to set both sides of the NCB Unit's router to Unconfigured mode.

After the signon message appears, press the "RSVC" button on the front of the connected NCB module. SETRTR will send the required messages to the router and exit.

APPENDIX B. MOUNTING OPTIONS

Wall mount and EIA 19" rack mount kits are available as options for the NCB from CTI Products, Inc. The wall mount kit includes brackets to allow a single NCB module to be mounted to any flat surface. The rack mount kit includes an adapter allowing up to three NCB modules to be mounted in a single rack unit height.

Rack Mount Option

The rack mount option allows up to three NCB modules to be mounted in a one rack unit height (1.75 inches) of a standard 19 inch rack. The modules are mounted in the rack plate by removing its' front bezel and remounting the module into the rack plate. Figure 6 shows an exploded view of the rack mount installation. The top diagram shows the front view of the bracket with one module installed. The bottom two diagrams show a side view of the module installation into the rack adapter and rack adapter installation into the rack, respectively.

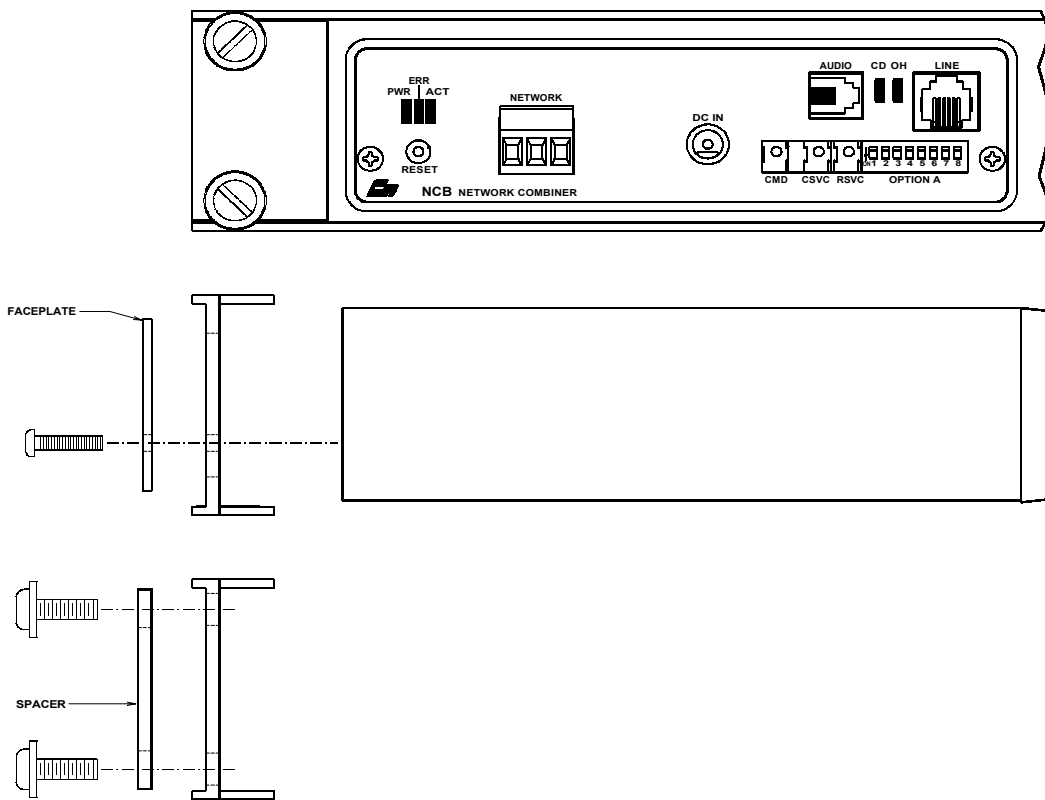

CA-80113-100

Figure 6 NCB Module Rack Mounting

To attach a module to the rack adapter, and then mount the rack adapter into the rack, follow the steps below.

WARNING

Do not allow the PC board to slide out of the housing when the front panel is removed. If it does, **DO NOT** slide the PC board back into the housing from the front of the module. Doing so may damage the unit, causing the unit to malfunction when powered on. Doing so will void the unit's warranty.

Rack Mounting Instructions

Step	Operation
1	Remove the front panel from the module, including the bezel, by removing the two Philips head screws in the faceplate. The bezel is not used when rack mounting the module.
2	Position the module behind the rack adapter, lining up the holes in the rack adapter with the front panel screw holes on the module.
3	Position the front panel in front of the rack adapter, lining up the front panel with the module.
4	Fasten the front panel and module to the rack adapter with the Philips head screws that were previously removed.
5	Position the rack adapter into your rack, lining up the four mounting holes of the rack adapter with mounting holes in the rack frame.
6	Position the two spacers in the front of the rack adapter, aligning the cutouts in the spacers with the holes of the adapter.
7	Install mounting screws (customer provided) into the rack.

When the front panel of the module is removed, do not allow the PC board to slide out of the housing. If the PC board does slide out of the housing, you must follow the steps below to replace the PC board in the housing. **DO NOT RE-INSTALL THE PC BOARD FROM THE FRONT OF THE HOUSING !**

Re-Installing a PC Board in its housing

Step	Operation
1	From the front of the module, slide the PC board out of the housing.
2	Remove the back panel of the module.
3	From the rear of the module, slide the PC board back into the housing (there are markings on the PC board to indicate which edge to insert into the rear of the housing first).
4	Install the back panel of the module.

Wall Mount Option

The wall mount option allows an NCB module to be mounted to any flat surface. The NCB module has four screw holes on the bottom. Simply attach the two mounting plates to the bottom of the module using the four flat-head screws provided with the wall mount kit. This assembly is then attached to the flat surface with user-provided fasteners. Figure 7 shows a dimensioned view of the wall mount installation.

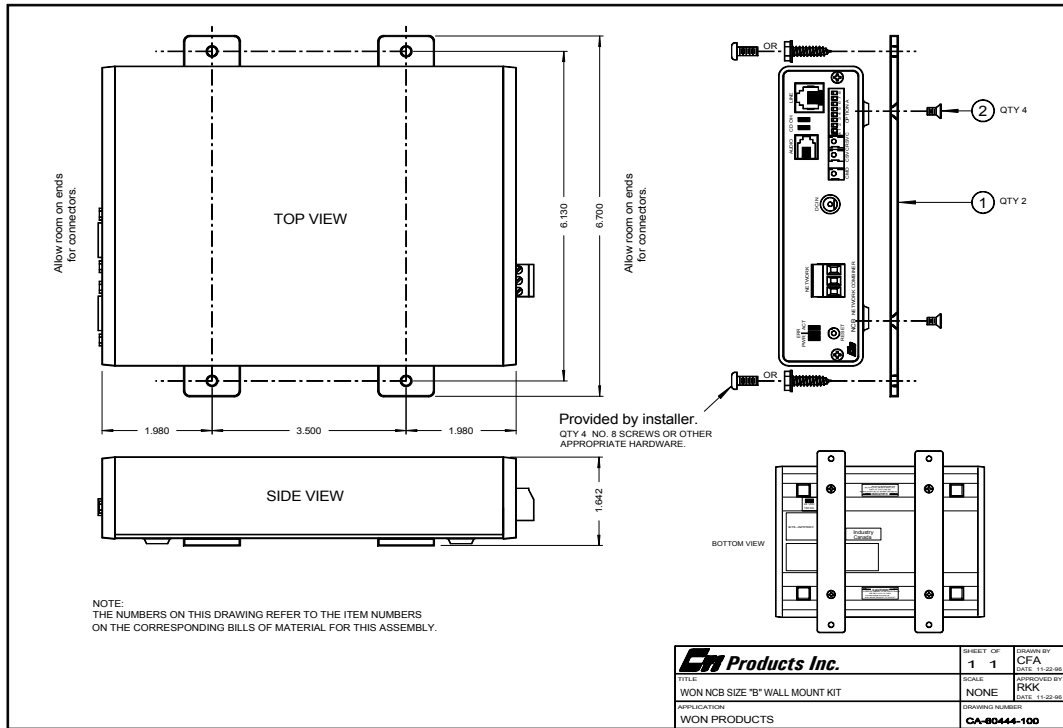

Figure 7 NCB Module Wall Mounting

CAUTION

Be sure to use the flat head screws provided with the wall mount kit. If you are not using the wall mount kit from CTI Products, Inc., make sure that the screws do not protrude into the enclosure more than 0.125 inches from the bottom surface of the module.

Using a longer screw that touches the PC board inside the module may damage the module. Doing so will void the unit's warranty.

APPENDIX C. CONNECTOR DETAILS

DC IN Connector

Connector type: 2.5 x 5.5 mm coaxial
 Mating Connector: Switchcraft 760 or equivalent
 Connector pinout: CTI Products, Inc. standard power supply wired with center pin positive, NCB module can accept either pin positive, polarity routing is provided internal.

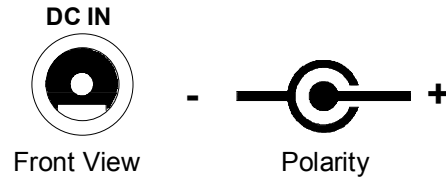

NETWORK Connectors

RJ-45 Connectors:

Pins 1 and 2 of both RJ-45 connectors as well as the terminal strip pins are all wired in parallel. The dual RJ-45 connector designates "IN" and "OUT". These designations apply only to DC power that is passed down unused pairs of the 4 pair network cable. The two pins carrying the network pair are straight-through.

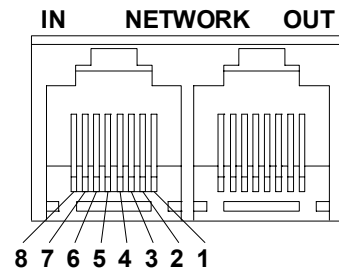

Connector Type: Standard RJ-45 telephone connector, 8 position 8 contact.

Pin	Function	Notes
1	Network	Network connection is NOT polarity sensitive
2	Network	Pins 1,2 of IN and OUT connectors tied parallel
3	+ DC Power	In on IN connector, Out on OUT connector
4	No Connection	
5	No Connection	
6	- DC Power	In on IN connector, Out on OUT connector
7	- DC Power	In on IN connector, Out on OUT connector
8	+ DC Power	In on IN connector, Out on OUT connector

2 Pin Terminal Strip style:

Mating Connector: Weidmuller 128176

Pin	Function
1	Network
2	Network

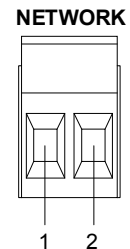

3 Pin Terminal Strip style:

Mating Connector: Weidmuller 128186

Pin	Function
1	Network
2	Network
3	Shield (RS-485 only)

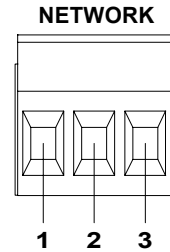

CA-80085-100

SMX Transceiver units:

SMX network connections are described in the documentation with the SMX transceiver.

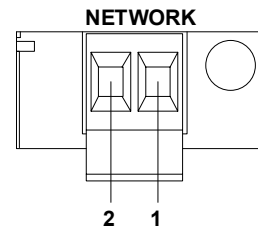

PORT 1 and PORT 2 Connectors

Connector type: Standard DE9 male

Data Format: 8 data bits, 1 stop bit, no parity

Data Characteristics: A series of bytes entering the "PORT 1" or "PORT 2" connectors must not have gaps between bytes greater than 500ms.

Handshaking: Activating the DSR input signal informs the NCB unit that the channel is active. If the channel does not directly support DSR, it must be strapped back to the (always active) DTR output signal.

Flow Control: CTS/RTS flow control can be used to pace the transmission of individual bytes between the NCB and a connected device. Sensing of CTS by the NCB can be enabled/disabled with the Option B switches. (See "STEP 2. SWITCH SETUP", in section "2. SETUP AND OPERATION".)

Miscellaneous: Pinout as DTE, arranged for direct connection to 25 pin connector using standard 9 pin to 25 pin cable. All signals except RI must be connected for proper operation.

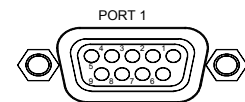

NCB Pin	Function	Direction	Radio Pin
1	DCD	Channel → NCB	8
2	RXD	Channel → NCB	3
3	TXD	NCB → Channel	2
4	DTR	NCB → Channel	20
5	ground		7
6	DSR	Channel → NCB	6
7	RTS	NCB → Channel	4
8	CTS	Channel → NCB	5
9	RI	Channel → NCB	22

APPENDIX D. TROUBLESHOOTING

Table D1

If the PWR LED . . .	REASON	CORRECTIVE ACTION
Is always illuminated.	Normal operation indicating that NCB unit is receiving proper DC input power.	Go to next Table.
Flashes for 2 seconds.	Normal operation when WINK command is being executed.	Go to next Table.
Flashes continuously.	DC input to unit is below minimum required voltage.	Check for proper voltage at “DC IN” connector (10-32VDC).
Does not illuminate.	NCB unit is not receiving DC input power.	Check for proper voltage at “DC IN” connector (10-32VDC).

Table D2

If the ERR LED . . .	REASON	CORRECTIVE ACTION
Is always off.	Normal operation indicating no error condition was detected.	Goto next Table.
Occasionally blinks on, then off.	Normal operation when “CSVC” button or “RSVC” button is pressed.	Go to next Table.
Flashes slowly, at a rate of once every 2 seconds.	The Router Neurons are unconfigured.	Use a Network Management Tool to ‘Replace’ or ‘Commission’ router, or Use NODEUTIL to change the mode/state to ‘Configured’ and ‘On-line’, or Use SETRTR –F to configure the router to Factory default conditions (Repeater Mode).
Flashes quickly, at a rate of twice per second.	1. A serial “PORT” is enabled, but is not terminated correctly to an active device.	1a. Either disable the serial “PORT” (setting the appropriate BAUD switch to ‘0’, or 1b. Terminate the serial “PORT” in an active device such as another NCB, a modem, or terminal adapter.
Is always illuminated.	Router module, or Control Neuron Processor, or Microprocessor is not functioning.	Call CTI Products, Customer Support (+1-513-595-5900), to arrange to return unit for evaluation/repair.

Table D3

If the ACT LED (on local NCB) . . .	REASON	CORRECTIVE ACTION
Occasionally blinks on, then off.	Normal operation indicating a message packet has passed through the router module of the NCB.	Go to next Table.
Does not illuminate when “RSVC” button on remote NCB is pressed.	<ol style="list-style-type: none"> 1. LONWORKS Service Pin message from remote NCB is not reaching the remote radio modem. 2. LONWORKS Service Pin message from remote NCB is not reaching the local radio modem. 3. LONWORKS Service Pin message from remote NCB is not reaching the local NCB. 4. LONWORKS Service Pin message from remote NCB is not passing through the local router module. 	<ol style="list-style-type: none"> 1a. Verify that “ACT” and “ERR” LED’s on remote NCB flash once. If not, return remote unit for evaluation/repair. b. Verify that “Traffic” and “Transmit” LEDs briefly illuminate on remote radio modem when the “RSVC” button is pressed on remote NCB. (Short and Mid Range only) c. If ‘1b’ is not ok, check serial cable connection between remote NCB and radio modem. 2a. Verify that Option B Switches are set the same on both NCBs, then reset both NCBs. b. Verify that “Traffic” LED briefly illuminates on local radio modem when the “RSVC” button is pressed on remote NCB. (Short and Mid Range only). 3. Check serial cable connection between the local NCB and radio modem. 4a. Place the remote router in Repeater mode and verify that the local “ACT” LED illuminates when “RSVC” button on remote NCB is pressed. b. If ‘4a’ is ok, re-commission the local NCB router. c. If ‘4a’ is not ok, swap either the local or remote unit with a known-good-unit to determine the faulty unit.
Does not illuminate when local LONWORKS nodes are transmitting messages.	<ol style="list-style-type: none"> 1. LONWORKS message packets from local nodes are not passing through the local router module. 	<ol style="list-style-type: none"> 1a. Verify the connection between the local LONWORKS nodes and the local NCB. b. Place the local router in Repeater mode and verify that its “ACT” LED illuminates when local LONWORKS nodes are transmitting messages. c. If ‘1b’ is ok, re-Commission the local NCB. d. If ‘1b’ is not ok, return the local NCB unit for evaluation/repair.

Table D3 continued on next page 

<p>Does not illuminate when remote LONWORKS nodes are transmitting messages.</p>	<ol style="list-style-type: none"> 1. LonWorks message packets from remote nodes are not passing through the remote router module. 2. LONWORKS message packets from remote nodes are not reaching the local NCB. 3. LonWorks message packets from remote nodes are not passing through the local router module. 	<ol style="list-style-type: none"> 1a. Verify the connection between the remote LonWorks nodes and the remote NCB. b. Verify that “ACT” LED on remote NCB illuminates when remote LonWorks nodes are transmitting messages. c. Place the remote router in Repeater mode and verify that its “ACT” LED illuminates when remote LonWorks nodes are transmitting messages. d. If ‘1c’ is ok, re-commission the remote router. e. If ‘1c’ is not ok, return unit for evaluation/repair. 2. See this Table above and verify that the “ACT” LED “Does not illuminate when “RSVC” button on remote NCB is pressed”. 3. See this Table above and verify that the “ACT” LED “Does not illuminate when “RSVC” button on remote NCB is pressed”.
--	---	--

Table D4

Miscellaneous:	REASON	CORRECTIVE ACTION
<p>Cannot communicate with Control Neuron Processor of local NCB when using NODEUTIL.</p>	<ol style="list-style-type: none"> 1. In Bridge or Configured modes, router neurons and network interface are not in the same domain. 2. In Repeater mode, the network interface may be defective. 	<ol style="list-style-type: none"> 1. Verify that Nodeutil can communicate with another LonWorks node. 2a. Place the local router neurons in Repeater mode and verify that communications is possible, or b. Use Nodeutil to change the network interface Domain to match the router neurons’ domains.
<p>Cannot communicate with the Control Neuron Processor of local NCB when using NCBCON.</p>	<ol style="list-style-type: none"> 1. In Bridge or Configured modes, the Control Neuron, the router neurons, and the network interface are not all in the same domain. (2) 2. In Repeater mode, the Control Neuron and network interface are not in the same domain. (1) 	<ol style="list-style-type: none"> 1. Place the local router neurons in Repeater mode. 2. Use NCBCON to change the network interface Domain to match the Control Neuron domain.
<p>Cannot commission the Control Neuron Processor when using LonMaker for Windows.</p>	<p>Incorrect external interface definition (.xfb or .xif file) was specified when commissioning node.</p>	<p>Use NCBTLC30 for Version 3 NCB Units. Use NCBTLC20 for NCB Units prior to Version 3.</p>

APPENDIX E. SPECIFICATIONS

NCB Unit

DC Power Input:	<i>10 to 30 VDC, Negative Ground, Externally Current Limited 5 watts maximum without SMX transceiver 10 watts maximum with SMX power line transceiver</i>
Size:	<i>7.5" D x 5.6" W x 1.6" H</i>
Operating Temperature:	<i>0 to 60 °C</i>
Humidity:	<i>10-95% non-condensing</i>
Mounting:	<i>Desktop with integral non-slip feet Wallmount or 19" rack mount with optional adapters</i>
Transceivers supported:	<i>FTT-10A, TPT/XF-78, TPT/SF-1250, SMX</i>
Maximum packet size:	<i>66 bytes (factory default router configuration) 255 bytes (maximum with software re-configuration)</i>
Serial Ports:	<i>2 Ports, one or two modems or adapters may be connected 1200 to 115200 bps 8 data bits, 1 stop bit, no parity</i>
Configuration:	<i>Factory default router mode is set to Repeater. Configured or Bridge mode set using standard LonWorks network management tools capable of configuring routers.</i>
Installation:	<i>Can be done with Standard Network Tools</i>
LONMARK [®] 3.2 Objects	<i>Modem Controller 5091 Telephone Directory 5092</i>
LONMARK [®] Program ID:	<i>80:00:60:32:5B:08:09:32</i>

INDEX

- A**
- ACT LED 6
 - Addressing 8, 21
 - Auto Answer Mode 19
- B**
- BAUD Switches 1, 9
 - Bindings 15
 - Bridge 4
 - Buffer Configuration 21
- C**
- CMD Button 19
 - Commissioning an NCB 11
 - Configuration 1
 - Configured router 4, 21
 - Connection Statistics 19
 - Connectors 10, 26
 - Control Neuron Processor 4, 6, 8, 12, 13, 21
- D**
- Dialing, Manual 18
 - Domain 4, 21, 22
- E**
- ERR LED 6, 9, 21
 - Error 6
 - Explicit Messages 5
 - External Radio 10
- F**
- Factory Default Parameters 21
 - Front Panel 6
 - Functional Block 15
- G**
- Global Control Object 16
- I**
- Internal router 4, 6, 15, 21
- L**
- LINE connector 4
 - LNS Plug-Ins 17
 - LONMAKER for Windows 11
 - LONWORKS 4, 12
- M**
- Manual Dialing 18
 - Message Buffer 5
 - Mode Switches 1, 9
 - Modem Controller object 15, 16
 - Mounting 8, 23
 - Mute Input Audio 19
- N**
- NCB/Plug Configuration Plug-In ii, 14, 17
 - NCB/Plug Installation 12, 17
 - NCBCON 5, 11
 - NETWORK connector 4, 10, 22
 - Network Management Tool 6, 9, 11, 21
 - Network Variables 14, 15
 - NV Bindings 15
 - NV Control 15
- O**
- Object -- Global Control 16
 - Object -- Telephone Directory 18
 - Objects 31
 - OPTION A Switches 1, 8
 - OPTION B Switches 1, 9
- P**
- PCNSS Card 5
 - Phone Book object 16
 - PORT 1 4, 9, 10, 27, 28
 - PORT 2 4, 9, 10, 27
 - Power Connection 10
 - Program ID 31
 - Pulse Router Service Pin 19
 - PWR LED 6
- Q**
- Quick Start 1
- R**
- Radio Configuration 1
 - Radio Connection 10
 - Rear Panel 7
 - Repeater 4, 21
 - Ring Mode 6, 19
 - RJ-45 10, 26
 - Router configuration 21
- S**
- Serial port 4, 6, 9
 - SETRTR.EXE 21
 - SMX 27
 - Soft Reboot 19

Specifications 31
Subnet/node 4, 8, 9, 21
Switch Settings 1
Switches -- BAUD Rate 1, 9
Switches -- Mode 1, 9
Switches -- OPTION A 1, 8
Switches -- OPTION B 1, 9

T

Telephone Directory object 18
Troubleshooting 28

W

Wink 6

X

XIF Files 12, 18

