



## IIB™ Input/Output Interface Module for MCN™ Monitoring and Control Systems



### Introduction

The IIB Input/Output Interface Module is part of CTI Products' Monitoring and Control Network (MCN™) system. It connects a parallel operator display device (such as a console) to the MCN Network.

The IIB is used with AIB ASTRO-TAC™ Comparator Interface Modules to provide voting status indications (Vote, Receive, Disable, and Fail) to a console. It also allows the console operator to Force-Vote and Disable receivers.

The IIB can also be used with CIB Comparator Interface Modules to extend the comparator display and control for other comparators (Digitac, Spectra-TAC, TAC, and EGE) over a long distance.

The IIB module takes MCN status messages (Vote, Receive, Disable, and Fail for comparators) from the network and provides output signals to the console I/O boards. It also takes Force Vote and Disable output signals from the console and sends commands to the comparator interface module over the network.

The IIB Input/Output Interface Module is compatible with:

- MCN CIB Comparator Interface Modules
- MCN AIB ASTRO-TAC™ Comparator Interface Modules
- Consoles with parallel inputs & outputs

### **Extend your Comparator Status Display and Control to Your Console!**

In some systems, comparators are not located close to the console electronics. With an IIB and a CIB or AIB, you can bring the comparator status information back to the console over an easy to install serial network cable, thus reducing wiring costs.

For ASTRO-TAC™ comparators, the IIB, along with an AIB, provides the parallel outputs a console needs to display the comparator Vote, Receive, Disable, and Fail indications.

With a comparator display at the console, an operator can see at a glance which receivers are receiving, voted, or failed, and which receiver is causing your system problems. A Force-Vote function permits audio monitoring of each receiver site. A Disable function shuts down bad receivers until repairs are made.

### **Repair Voting System Problems Efficiently!**

With the MCN Remote Comparator Display, your operators can provide a technician with an accurate description of the system failure. By isolating a failure to a specific voting receiver, valuable technician time is saved and receiver down-time is reduced.

The system can help pinpoint intermittent system problems, eliminating repeated service calls to the comparator just to isolate a bad receiver.

### **System Options**

The following are some of the MCN system options available to work with the IIB module:

- CIB Comparator Interface Modules
- AIB ASTRO-TAC™ Comparator Interface Modules
- Quad Mounting Rack (1.75" high) for mounting 4 IIBs or other size A MCN modules
- AC Power supplies for 120 or 240 VAC
- Network cables and terminators
- EXB System Extenders

CTI Products, Inc.  
1211 West Sharon Road  
Cincinnati, Ohio 45240  
USA

phone  
+1.513.595.5900

fax  
+1.513.595.5983

e-mail  
[info@ctiproducts.com](mailto:info@ctiproducts.com)

[www.ctiproducts.com](http://www.ctiproducts.com)

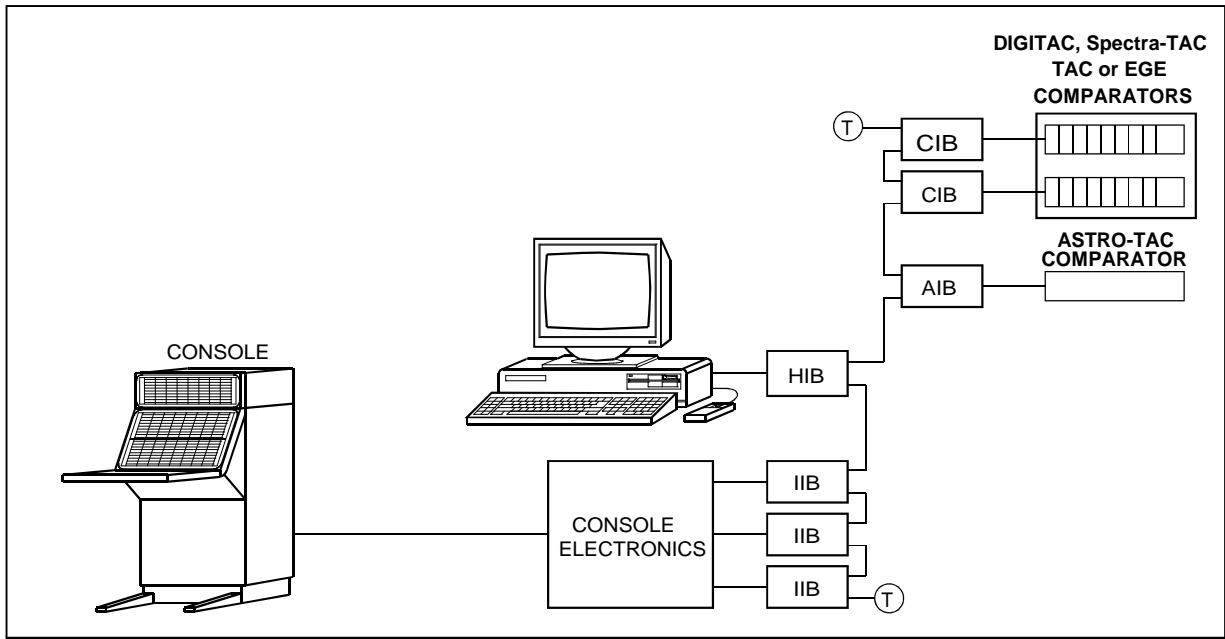

Typical MCN Remote Comparator Display System

**The How the System Works**

The MCN Remote Comparator Display includes two basic parts: the Comparator Interface Modules and the Operator Interface.

The Comparator Interface Modules (CIBs and AIBs) mount near the comparator. They pass the Vote, Receive, Disable, and Fail signals from the voting comparator to the MCN network.

The receiver data is passed over the network to Operator Interfaces, such as HIBs and IIBs. The diagram shows PCs connected to the network via HIB Host Interface Modules. Consoles are connected via IIB I/O Interface Modules.

The Operator Interfaces (HIBs and IIBs) accept Force-Vote and Disable signals from the PC or console and generate Force-Vote and Disable commands on the network.

The comparator interface modules (CIBs and AIBs) accept Force Vote and Disable commands from the network and generate the Force Vote and Disable signals to the comparator.

**Multiple Displays**

The IIB modules will typically be connected at one location to central console electronics. The console system then provides multiple console display & control positions. PC Displays and Console Displays (HIBs and IIBs) may both monitor & control a single comparator with some limitations.

**Other MCN System Products**

The IIB Input/Output Module is just one module in the MCN series. Other modules may be used for other control, monitoring, and alarm applications. Call our Systems Engineers to find out how an MCN Comparator Display System can be configured to fit your specific needs.

**General Specifications**

Size (MCN Size A):	5.5" x 4.2" x 1.5" (140 x 107 x 38 mm)
Weight:	16 oz, (455 g)
Temperature:	0-50 °C
Humidity:	10- 95% non-condensing
Receivers controlled:	8 per IIB (Selectable in banks for connection to AIBs. Two IIBs are required to monitor and control 16 receivers on an AIB.)
Bi-directional Inputs / Outputs per receiver:	2: Vote (Force Vote) and Disable
Outputs per receiver:	2: Force Vote, Disable Logic Levels, active low
Max I/O voltage:	+30 VDC
Comparator Connector	50 pin Telco style, Female
Network Connectors:	(2) RJ-45 (1 in, 1 out)
Max. network segment:	4000 ft. without repeaters
Max. IIB modules:	40 per network segment (Larger, multi-segment systems can be custom-configured.)
Network Cabling	4 Pair Level 4 UTP
Power Input	12 to 30 VDC / 2 W
Safety Approvals to:	UL 1950, CSA 1950 EN60950-1992 (CE)
Emissions Compliance:	FCC part 15, Class A IC (DOC), Class A (Canada) EN55022, Class A
Susceptibility Compliance:	IEC 801-2, 3, 4 EN50082-1