

***MCN Monitoring and Control Network
Comparator Display System***

***Comparator I/O Module
CIB
Hardware Reference Manual***

S2-60426-135

Note:

***Jumpers & switch settings vary depending upon the
type of comparators or voters used.***

***Be sure to verify jumper and switch settings before
connecting the units to your comparators or voters.***

***Be sure to set the rotary address switches to the
proper addresses before installing the system.***

FCC Statement

This equipment has been tested and found to comply with the limits for a Class A digital device, pursuant to Part 15 of the FCC Rules. These limits are designed to provide reasonable protection against harmful interference when the equipment is operated in a commercial environment. This equipment generates, uses, and can radiate radio frequency energy and, if not installed and used in accordance with the instruction manual, may cause harmful interference to radio communications. Operation of this equipment in a residential area is likely to cause harmful interference in which case the user will be required to correct the interference at his own expense.

Warning: Changes or modifications to this unit not expressly approved by the party responsible for compliance could void the user's authority to operate the equipment.

DOC Statement

This Class A digital apparatus meets all requirements of the Canadian Interference-Causing Equipment Regulations.

Cet appareil numérique de la classe A respecte toutes les exigences du Règlement sur le matériel brouilleur du Canada.

Computer Software Copyrights

This manual describes products which include copyrighted CTI Products, Inc. computer programs in semiconductor memory. CTI Products, Inc. reserves all rights for these programs, including the exclusive right to copy or reproduce the copyrighted computer programs in any form. No copyrighted computer program contained in products described in this manual may be copied, reproduced, decompiled, disassembled, or reversed engineered in any manner without express written permission of CTI Products, Inc. The purchase of products from CTI Products, Inc. shall not be deemed to grant either directly or by implication, estoppel, or otherwise, any license under the copyrights, patents, or patent applications of CTI Products, Inc., except for the normal non-exclusive, royalty fee license to use that arises by operation of law in the sale of the product.

Information contained in this document is subject to change without notice and does not represent a commitment on the part of CTI Products, Inc.

No part of this manual may be reproduced or transmitted in any form or by any means, electronic or mechanical, including photocopying and recording, for any purpose without the written permission of CTI Products, Inc.

Copyright 1995-1998 CTI Products, Inc. All rights reserved.

MCN is a trademark of CTI Products, Inc. Other trademarks referenced are properties of their respective owners.



CIB Hardware Reference CTI Products, Inc.

Standard Limited Hardware Warranty

LIMITED WARRANTY. Equipment manufactured by CTI Products, Inc. is warranted to be free from defects in material and workmanship for a period of ONE (1) YEAR from date of shipment to original purchaser. Under this warranty, our obligation is limited to repairing or replacing any equipment proved to be defective by our inspection within one year of sale to the original purchaser. This warranty shall not apply to equipment which has been repaired outside our plant in any way, so as to, in the judgment of CTI Products, Inc. affect its stability or reliability, nor which has been operated in a manner exceeding its specifications, nor which has been altered, defaced, or damaged by lightning.

CUSTOMER REMEDIES. In the event of a defect, malfunction, or failure to conform to specifications established by the seller during the period shown, the customer shall call CTI Products, Inc. to obtain a Return Authorization Number and return the product or module, shipping and insurance prepaid. CTI Products, Inc., will then at its option, either repair or replace the product or module and return it, shipping prepaid, or refund the purchase price thereof. On-site labor at the purchaser's location is not included in this warranty.

EQUIPMENT NOT MANUFACTURED BY CTI Products, Inc. Equipment not manufactured by CTI Products, Inc. is excluded from this warranty, but is subject to the warranty provided by its manufacturer, a copy of which will be supplied to you upon specific written request.

NO OTHER WARRANTIES. The foregoing constitutes the sole and exclusive remedy of the buyer and exclusive liability of CTI Products, Inc., AND IS IN LIEU OF ANY AND ALL OTHER WARRANTIES EXPRESSED OR IMPLIED OR STATUTORY AS TO MERCHANTABILITY, FITNESS FOR PURPOSE SOLD, DESCRIPTION, QUALITY, PRODUCTIVENESS OR ANY OTHER MATTER.

NO LIABILITY FOR CONSEQUENTIAL DAMAGES. WITHOUT LIMITING THE FOREGOING, IN NO EVENT SHALL CTI PRODUCTS, INC. OR ITS SUPPLIERS BE LIABLE FOR ANY DAMAGES WHATSOEVER (INCLUDING, WITHOUT LIMITATION, SPECIAL, INCIDENTAL OR CONSEQUENTIAL DAMAGES OR FOR LOSS OF BUSINESS PROFITS, BUSINESS INTERRUPTION, LOSS OF BUSINESS INFORMATION, OR OTHER PECUNIARY LOSS) ARISING OUT OF THE USE OF OR INABILITY TO USE CTI PRODUCTS, INC. EQUIPMENT BY PURCHASER OR OTHER THIRD PARTY, WHETHER UNDER THEORY OF CONTRACT, TORT (INCLUDING NEGLIGENCE), INDEMNITY, PRODUCT LIABILITY OR OTHERWISE, EVEN IF CTI PRODUCTS, INC. HAS BEEN ADVISED OF THE POSSIBILITY OF SUCH DAMAGES OR LOSSES. IN NO EVENT SHALL CTI PRODUCTS, INC.'S, LIABILITY EXCEED THE TOTAL AMOUNT PAID BY PURCHASER FOR THE EQUIPMENT GIVING RISE TO SUCH LIABILITY

Manual Revisions:

- S2-60426-100 Original Release
- S2-60426-105 Minor revisions
- S2-60426-110 Added description for Option Switch 3 (TIB Support) for CIBs version 105 and up.
- S2-60426-115 Added description for Option Switch 4 (Force Vote Timeout) for CIBs version 110 and up.
- Added instructions for JPS SNV-12 voters and Doug Hall 4RV/2 Voters.
- Re-formatted wiring tables. & enhanced Troubleshooting section
- S2-60426-120 Added description for Option Switch 4 (Force Vote Timeout) for CIBs version 110 and up.
- Added Punch-Block Order J1 Pinout.
- S2-60426-125 Changed Spectra-TAC jumpering (and default jumpering) for +5 V pull-up.
- Added warning about removing and inserting Spectra-TAC SQM modules under power.
- Changed comparator-specific pinout to include both logical order and punch block orders.
- Added description of the Backplane Modification for Ericsson / GE voters.
- S2-60426-130 Corrected JPS Pinout
- S2-60426-135 Corrected Digitac switch settings on Connector Pinout sheets

CTI Products, Inc.
1211 W. Sharon Rd.
Cincinnati, OH 45240

If you have questions about the MCN comparator display system, call us at:
(513) 595-5900. (8:30 to 5:00 Eastern)

68-10854-135

TABLE OF CONTENTS

1. INTRODUCTION	1
1.1 REFERENCE DOCUMENTS	1
2. SPECIFICATIONS	2
3. THEORY OF OPERATION	4
3.1 COMPARATOR STATUS	4
3.2 CONTROLLING THE COMPARATOR	4
3.3 SYSTEM EXAMPLE	4
3.4 BI-DIRECTIONAL I/O SIGNALS	5
3.5 TRANSMITTER STATUS MONITORING AND CONTROL	5
3.6 OPERATION WITH A SPECTRA-TAC COMPARATOR	6
3.7 OPERATION WITH A DIGITAC COMPARATOR	6
3.8 OPERATION WITH A JPS SNV-12 VOTER	7
3.9 OPERATION WITH A DOUG HALL 4RV/2 VOTER	7
4. OPTION SWITCHES & JUMPERS	8
4.1 GROUP & MODULE SWITCHES	8
4.2 COMPARATOR SELECTOR SWITCHES	8
4.3 TRANSMITTER MONITORING (TIB) ENABLE SWITCH	9
4.4 FORCE-VOTE TIMEOUT SWITCH	9
4.5 JUMPER OPTIONS	10
5. CONNECTORS	11
6. MOUNTING	15
7. COMPARATOR WIRING LISTS	17
7.1 MOTOROLA TAC COMPARATOR	18
7.2 MOTOROLA SPECTRA TAC COMPARATOR	20
7.3 MOTOROLA DIGITAC COMPARATOR	22
7.4 M/A-COM / ERICSSON / G.E. ANALOG VOTER	24
7.4.1 <i>Voter Modifications For Receiver Module Fail Monitoring</i>	26
7.5 JPS SNV-12 VOTER	27
7.5.1 <i>JPS Voter Modifications for Monitoring Voted Out using Channel Select In</i>	29
7.6 DOUG HALL 4RV/2 VOTER	30
8. MODULE ERROR CODES	32
9. TROUBLESHOOTING	33

1. Introduction

The Comparator Interface Module (CIB) is a member of the Monitoring and Control Network (MCN™) family of **Comparator I/O Modules**. Hardware specifications, special installation, and configuration information are described in this manual.

The CIB module connects a parallel I/O comparator to the MCN network. The CIB is used with the comparator and a User Interface Module (such as a HIB or IIB) and an operator station to create a comparator display system. The comparator display system provides monitoring and control functions for your communications system. Receiver states monitored by the CIB include VOTE, RECEIVE, DISABLE and FAIL. Receiver functions that can be controlled include FORCE VOTE and DISABLE. The following parallel I/O comparators are supported by the CIB module:

- Motorola TAC
- Motorola Spectra TAC
- Motorola Digitac
- M/A-Com / Ericsson / G.E. Analog Voters
- JPS SNV/12
- Doug Hall Electronics 4RV/2

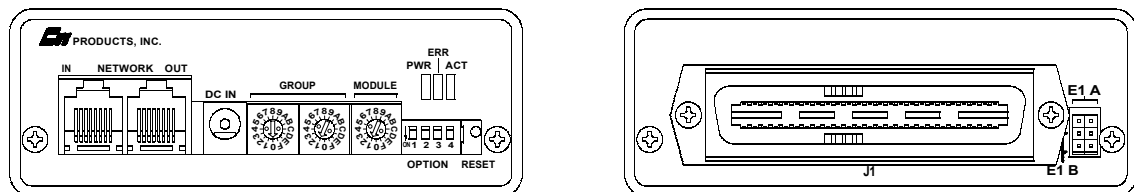

CA-80023-100

Figure 1 - CIB Front and Rear View

1.1 Reference Documents

1. Monitoring and Control Network System Manual
Part Number S2-60425
2. TSAM Interface Module (TIB) Hardware Reference Manual
Part Number S2-60469

2. Specifications

Size	5.5" x 4.2" x 1.5" (140 x 107 x 38 mm)
Weight	16 oz (455 gm)
Temperature	0 - 50 °C
Humidity	10 - 95% non-condensing
Module Power	10 - 32 Vdc / 2 Watts max.
Number of Receivers Supported	8
Open Circuit Voltage (all I/O pins) jumper E1B removed jumper E1B installed	+15 Vdc nominal +5 Vdc nominal
Inputs per Receiver active low, pull-up to +5 or +15 Vdc	Vote, Receive, Disable and Fail
Input Voltage (Input and In/Out pins)	-0.6 to 30 Vdc max
Input Current (Input and In/Out pins): jumper E1B removed (Vin = 0 Vdc) jumper E1B installed (Vin = 0 Vdc)	-720 µA max (source) -270 µA max (source)
Outputs per Receiver (active low)	Force Vote and Disable
Output Saturation Voltage (Outputs and In/Out pins) with Iout = 100 mA	550 mV max.
Output Pin Current (Outputs and In/Out pins)	150 mA max per pin (sink) 100 mA max per pin if all output are ON
Maximum Power Dissipation	2 Watts
Input/Output Connection	50 pin Telco style
Network Connector	(2) RJ-45 (1 in, 1 out)
Safety Approvals	UL 1950 CSA 1950 EN 60950-1992
Emissions Compliance	FCC Part 15, Class A DOC Class A EN55022
Susceptibility Compliance	IEC 801-2 IEC 801-3 IEC 801-4 EN50082-1

Table 1 - Module Specifications

Figure 2 shows the equivalent circuits of the CIB I/O pins. The pull-up voltage V_p by jumper E1B, located on the rear of the module.

- $V_p = 15\text{ Vdc}$ with jumper E1B out
- $V_p = 5.0\text{ Vdc}$ with jumper E1B in

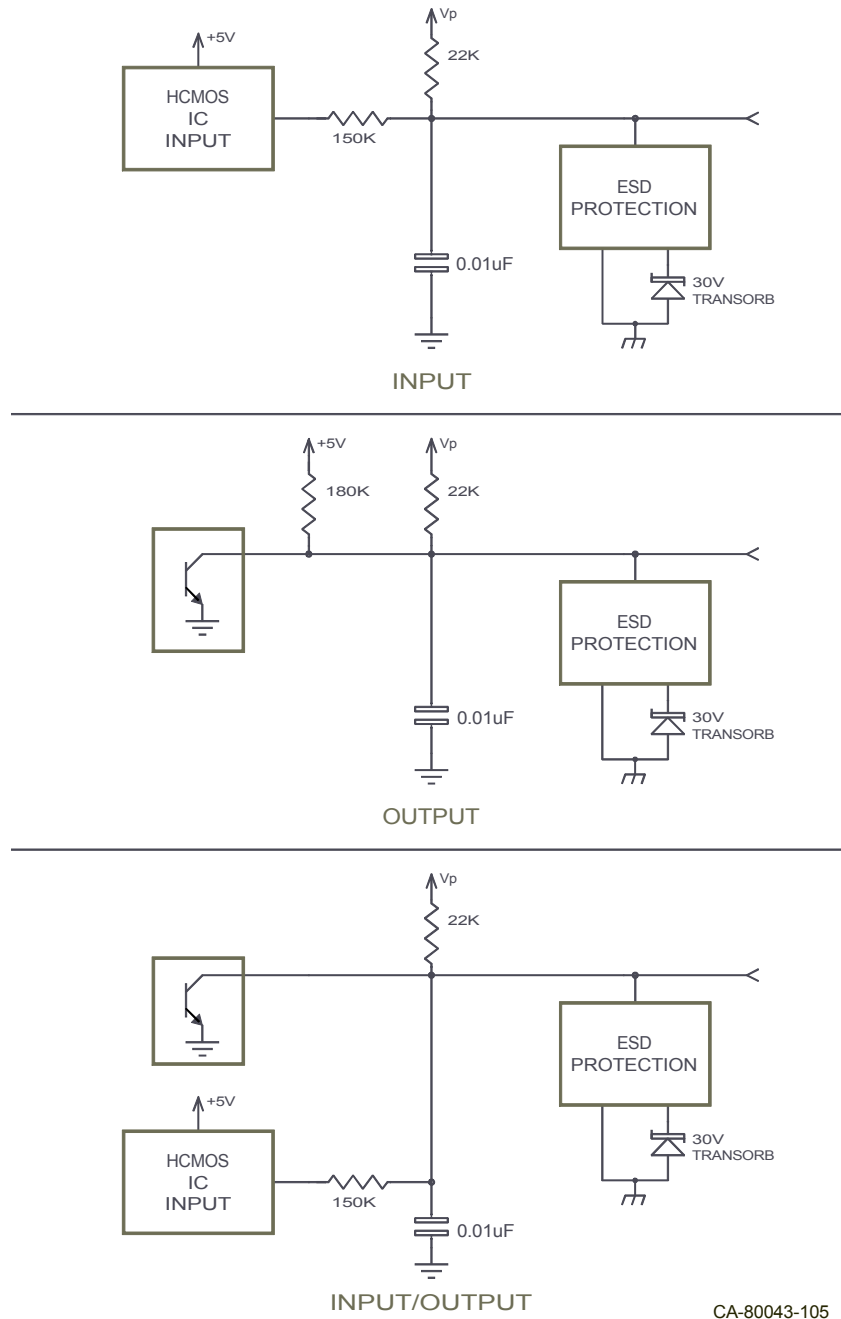

CA-80043-105

Figure 2 - I/O Equivalent Circuit

3. Theory of Operation

This section describes the operation of the CIB module in an MCN comparator display system.

3.1 Comparator Status

The CIB can accept VOTE, RECEIVE, DISABLE, and FAIL receiver status indications from the comparator. Some comparators do not support all of these status monitoring signals. Refer to section 7 for details about wiring the CIB to a particular comparator. The CIB sends the status information to a User Interface Module over the MCN network. User Interface Modules, such as the IIB (I/O Interface Module) or HIB (Host Computer Interface Module) then display the comparator status information on a console or PC.

3.2 Controlling the Comparator

When a User Interface Module sends FORCE VOTE or DISABLE commands, the CIB translates the commands and activates the appropriate I/O lines of the comparator.

The CIB updates the comparator with the latest control information whenever a FORCE VOTE or DISABLE command is received from a User Interface Module.

3.3 System Example

Figure 3 shows an example comparator display system using the CIB module.

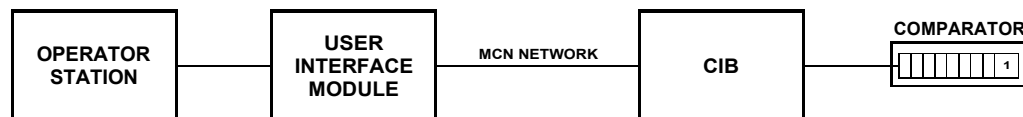

CA-80052-100

Figure 3 - CIB System Example

When the comparator detects that a receiver is active, it drives the RECEIVE inputs to the CIB. If the receiver is also voted by the comparator, the comparator drives the VOTE input as well. The CIB detects these inputs and sends receive and vote messages to the User Interface Module. The User Interface Module then indicates that the receiver is active and voted. If the User Interface Module is an IIB, the IIB activates the VOTE and RX outputs for that receiver.

If the comparator detects that a receiver has failed, then it drives the FAIL input to the CIB. Again, the CIB detects this FAIL input and sends a message to the User Interface Module so that the user can see that the receiver has failed.

From the operator station, the user can generate FORCE VOTE or DISABLE commands for each receiver in the system. The User Interface Module detects these commands and sends them to the CIB. The CIB then drives the appropriate VOTE or DISABLE outputs to the comparator, telling it which receivers were force voted or disabled.

3.4 Bi-directional I/O Signals

The CIB provides two input/output lines per receiver (VOTE and DISABLE) that allow both monitoring and control of the signal (Figure 2 shows the equivalent circuit for the input/output lines). If a receiver is disabled at the comparator, the CIB will send a message to the User Interface Module so that the disabled indication for the receiver can be shown at the operator station. Because the comparator is now driving the input of the bi-directional DISABLE line, the receiver cannot be re-enabled from the operator station. Pressing a disable button on the operator station will have no effect on the receiver. If the disable button is pressed multiple times, you could end up with the disable output latched on (depending upon how many times the disable button is pressed). If this happens, when the receiver is re-enabled at the comparator, the operator station will still show the receiver being disabled when in fact the receiver is enabled. If you re-enable a receiver at the comparator and the Disable indication remains on, re-enable the receiver through the MCN system.

3.5 Transmitter Status Monitoring and Control

The MCN family includes an auxiliary module that allows monitoring and control of transmitter sites. This module is called a TSAM Interface Module, or TIB, and it interfaces between the CIB and CTI Product's Transmitter Steering Audio Matrix (TSAM) device (see reference 2). The CIB passes FORCE VOTE information to the TIB to control or select the active transmitter. The TIB passes transmitter information to the CIB so that the active transmitter can be displayed with a User Interface Module that supports display of transmitter status, such as a HIB with MCNRCD running on a PC.

The CIB will provide this transmitter monitoring and control only if its transmitter monitoring enable switch, OPTION switch 3, is in the UP position. If this switch is in the DOWN position, all transmitter monitoring and control is disabled.

The CIB and TIB communicate over the MCN network so no special wiring is required between the modules.

3.6 Operation With a Spectra-TAC Comparator

Some Motorola Spectra-TAC comparators with the "B" version Signal Quality Module (SQM) can be damaged when a voltage greater than the comparator's supply voltage is applied externally on the Disable input. (Motorola fixed this problem in the "C" version SQM.) CIB modules shipped after January, 2003 are shipped with E1B In, setting the input pull-up to +5 VDC.

Warning

Some "B" version SQM modules have a problem when they are inserted or removed under power. Depending upon which pins connect first, the module may be destroyed if there is an external connection to the Disable pin. The module will try to power itself through the Disable pin and will destroy IC U3.

When inserting or removing the SQM from the comparator shelf, be sure to first disable the module from the front panel switch on the SQM. This will assure that the Disable input is grounded. After the module is re-inserted, turn off the Disable switch.

3.7 Operation With a Digitac Comparator

Installation Notes

- A Digitac Comparator can be connected to a CIB module with a straight through 50-pin cable. Jumper E1-A and E1 B must be out. See the CIB to Digitac wiring chart. Be sure to set the Option Switches for Digitac Comparator.
- The switches and jumpers on the CIB module are difficult to reach after the module is mounted to the comparator. Always set the switches and jumpers for the CIB module before installing it on the back of the Digitac comparator.

Fail & Disable

The Motorola Digitac Comparator drives its Fail/Disable line low when:

- A receiver input has failed (loss of status tone).
- A receiver is disabled from the switch on the front panel of the comparator.

In either of these two cases, the MCNRCD software will display a "FAIL" indication on the PC.

The MCNRCD software will display a "DISABLE" when the receiver site is disabled from the PC, since the CIB is generating the Disable signal..

Coded Mode

The Digitac "Mode" (Coded) outputs appear on CIB "Fail" inputs. When you set the CIB switches to Digitac mode, the CIB module ignores the Fail inputs. If the switches are set improperly, you will see a "Fail" indication whenever the Digitac receives a Coded transmission.

3.8 **Operation With a JPS SNV-12 Voter**

The JPS SNV-12 voter has the following differences:

- The front panel and RS-232 “DISABLE” signals are not brought to the rear terminal block connector of the Voter modules.
- The front panel and RS-232 “SELECT” signals are not brought to the rear terminal block connector of the Voter modules.

Since these signals are not available to the CIB module, the MCNRCD software will not display the front panel switch / RS-232 DISABLE and SELECT activity for the SNV-12 voter card.

3.9 **Operation With a Doug Hall 4RV/2 Voter**

The DH 4RV-2 voter has opto-isolated inputs that allow the voter to work with signals that go below ground (negative). These signals may be present when these voters are used with positive ground equipment, such as microwaves. The CIB module only functions properly with signal levels which are NOT below ground.

CAUTION

Do not operate a CIB module with any system that has signal levels that go below ground level!

Damage to the CIB module can result and will void the warranty.

4. Option Switches & Jumpers

Three sets of option switches are provided for module configuration. The module must be power cycled or reset after these switches are set so that the options will take effect. Table 2 describes the option switches and shows the factory defaults.

SWITCH	DESCRIPTION	DEFAULT
GROUP	unit address setting (00-FE) refer to the MCN System Manual	00
MODULE	unit address setting (0-F) refer to the MCN System Manual	0
OPTION position 1	comparator selector 1 (see Table 3)	DOWN
position 2	comparator selector 2 (see Table 3)	DOWN
position 3	transmitter monitoring enable	DOWN
position 4	force-vote timeout	DOWN

Table 2 - CIB Option Switches

4.1 Group & Module Switches

The Group and Module selector switches are used to set the node address during module installation. Refer to the Monitor and Control Network System Manual for details about setting these switches.

4.2 Comparator Selector Switches

The comparator selector switches set the type of comparator the CIB is operating with. Settings for these switches are shown in Table 3.

Comparator Selector 1 SW 1	Comparator Selector 2 SW 2	Comparator Type Selected
DOWN	DOWN	Spectra TAC
DOWN	UP	Digitac
UP	DOWN	TAC, G.E., JPS SNV-12, Doug Hall 4RV/2
UP	UP	other

Table 3 - Comparator Selector Switch Settings

If your specific comparator is not listed in Table 3, set both comparator selection switches to the UP position for “other”. With this setting, the CIB will monitor the VOTE, RECEIVE, DISABLE, and FAIL inputs from the comparator and pass the status information to the display interface module. Also, the display interface module can control the VOTE and DISABLE outputs of the CIB.

4.3 Transmitter Monitoring (TIB) Enable Switch

(CIB Versions 105 and greater)

The transmitter monitoring enable switch allows the CIB to operate with any MCN family module that provides monitoring and control of transmitter steering, such as the MCN TSAM Interface Module (TIB). Table 4 lists the functions and positions of this switch. Refer to section 3.5 for more information about transmitter status monitoring and control. If you enable the Transmitter Monitoring feature, be sure to connect a TIB module which is properly addressed, otherwise the CIB will have erratic operation.

Transmitter Monitoring Switch SW3	Transmitter Status (TIB support)
UP	Enabled
Down	Disabled

Table 4 - Transmitter Monitoring Enable Switch

4.4 Force-Vote Timeout Switch

(CIB Versions 110 and greater)

If you are using a dial-up connection to the MCN system and the modem disconnects when you are force-voting a receiver, the CIB would not see the “Release” message from the PC. This would force the system to continuously vote the force-voted receiver.

The Force-Vote Timeout switch enables a 60-second timeout for all the Force-Vote (Monitor) lines. This feature was added in CIB version 110. The 60-second timeout is used to limit the time that a receiver may be force-voted. If you lose a connection during a force-vote, the system will revert to normal in 60 seconds maximum. It is recommended that this switch be UP to enable the timer in all systems unless you need a continuous Force-Vote for longer than 60 seconds.

Force-Vote Timeout Switch SW 4	Force-Vote Timeout
DOWN	Disabled (No Timeout)
UP	60 Second Timeout

Table 5 - Force-Vote Timeout Switch Settings

4.5 Jumper Options

Figure 4 shows the configuration of the two jumper options available on the rear of the CIB. These jumpers should be installed at system installation time with power removed from the CIB.

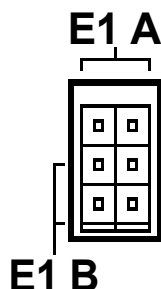

CA-80024-100

Figure 4 - Jumper Options

Jumper E1A is located across the top 2 terminals of the 6 pin terminal block. Jumper E1B is located across the left side middle and bottom terminals of the 6 pin terminal block. The remaining 2 terminals of the block are unused.

Jumper	Function	Default
E1A	In to enable output MON 7. Out to disable output MON 7. (For Digitac only)	IN
E1B	In for inputs pulled up to +5 Vdc. (Spectra-TAC w/ "B" SQMs) Out for inputs pulled up to +15 Vdc.	IN

Table 6 - Jumper Options Description

The MON7 line conflicts with a Digitac signal. Always remove E1A when using the CIB with a Digitac comparator.

Some Spectra-TAC comparators with the "B" version Signal Quality Module (SQM) can be damaged when 15V is applied externally on the Disable input. For this reason, for CIB modules shipped after January, 2003 are shipped with E1B In, setting the input pull-up to +5 VDC.

Remove the E1B jumper if your comparator requires +15 V pull-ups.

5. Connectors

The **NETWORK IN/OUT** ports on the front of the CIB are used to connect the CIB with other MCN modules. These ports carry both the network data signals as well as DC power for power distribution with other modules. Table 7 gives the pinout for these connectors. Figure 5 shows the location of pin 1 for each port.

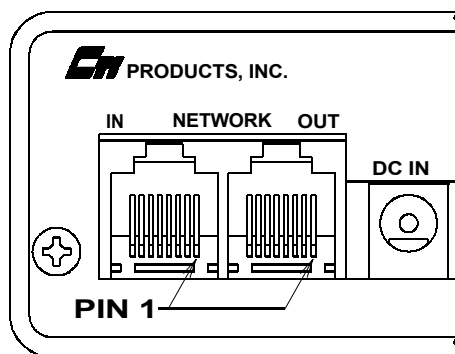

CA-80068-100

Figure 5 - Network IN/OUT Ports

Pin	Function
1	DATA +
2	DATA -
3	+ POWER
4	No Connect
5	No Connect
6	- POWER
7	- POWER
8	+ POWER

Table 7 - Network Connector Pinout

The **DC IN** port provides the primary power connection to the module. Power is distributed through the **NETWORK OUT** connector to provide power to the **NETWORK IN** connector of the MCN unit it is connected to. Each power supply can power up to four units total. See reference 1 for complete details of connections to the network and DC IN connectors.

Connector J1 provides the discrete I/O for the receiver signals. Table 9 gives the pinout for this connector. Table 8 describes the functions of the I/O signals.

Signal	Direction	Description
VOTE	Input/Output	Output activated to force vote a receiver. Comparator grounds input to indicate a voted receiver.
RX	Input	Ground to indicate that a signal is being received.
DIS	Input/Output	Output activated to disable a receiver. Ground input to indicate a disabled receiver.
FAIL	Input	Ground input to indicate a failed receiver.
MON	Output	Activated to force vote a receiver in the TAC and Ericsson / G.E. comparators. Unused for all other comparators.

Table 8 - I/O Signal Descriptions

CIB Connector J1 Pinout in Logical Order

CIB J1	Function	Direction	Wire Color
21	Vote 1	Input/Output	Blu/Vio
22	Rx 1	Input	Org/Vio
20	Dis 1	Input/Output	Slit/Yel
23	Fail 1	Input	Grn/Vio
19	Mon 1	Output	Brn/Yel
46	Vote 2	Input/Output	Vio/Blu
47	Rx 2	Input	Vio/Org
45	Dis 2	Input/Output	Yel/Slit
48	Fail 2	Input	Vio/Grn
44	Mon 2	Output	Yel/Brn
15	Vote 3	Input/Output	Slit/Blk
16	Rx 3	Input	Blu/Yel
14	Dis 3	Input/Output	Brn/Blk
17	Fail 3	Input	Org/Yel
12	Mon 3	Output	Org/Blk
40	Vote 4	Input/Output	Blk/Slit
41	Rx 4	Input	Yel/Blu
39	Dis 4	Input/Output	Blk/Brn
42	Fail 4	Input	Yel/Org
37	Mon 4	Output	Blk/Org
9	Vote 5	Input/Output	Brn/Red
10	Rx 5	Input	Slit/Red
8	Dis 5	Input/Output	Grn/Red
11	Fail 5	Input	Blu/Blk
6	Mon 5	Output	Blu/Red
34	Vote 6	Input/Output	Red/Brn
35	Rx 6	Input	Red/Slit
33	Dis 6	Input/Output	Red/Grn
36	Fail 6	Input	Blk/Blu
31	Mon 6	Output	Red/Blu
3	Vote 7	Input/Output	Grn/Wht
4	Rx 7	Input	Brn/Wht
2	Dis 7	Input/Output	Org/Wht
5	Fail 7	Input	Slit/Wht
18	Mon 7	Output	Grn/Yel
28	Vote 8	Input/Output	Wht/Grn
29	Rx 8	Input	Wht/Brn
27	Dis 8	Input/Output	Wht/Org
30	Fail 8	Input	Wht/Slit
26	Mon 8	Output	Wht/Blu
1	Ground		Blu/Wht
7	unused	No Connect	Org/Red
13	unused	No Connect	
24	unused	No Connect	
25	unused	No Connect	
32	unused	No Connect	
38	unused	No Connect	
43	unused	No Connect	
49	unused	No Connect	
50	unused	No Connect	

**Table 9 - CIB Connector J1 Pinout in Logical Order
 CIB Connector J1 Pinout in Punch-Block Order**

CIB J1	Function	Direction	Wire Color
26	Mon 8	Output	Wht/Blu
1	Ground		Blu/Wht
27	Dis 8	Input/Output	Wht/Org
2	Dis 7	Input/Output	Org/Wht
28	Vote 8	Input/Output	Wht/Grn
3	Vote 7	Input/Output	Grn/Wht
29	Rx 8	Input	Wht/Brn
4	Rx 7	Input	Brn/Wht
30	Fail 8	Input	Wht/Slt
5	Fail 7	Input	Slt/Wht
31	Mon 6	Output	Red/Blu
6	Mon 5	Output	Blu/Red
32	unused	No Connect	
7	Unused	No Connect	Org/Red
33	Dis 6	Input/Output	Red/Grn
8	Dis 5	Input/Output	Grn/Red
34	Vote 6	Input/Output	Red/Brn
9	Vote 5	Input/Output	Brn/Red
35	Rx 6	Input	Red/Slt
10	Rx 5	Input	Slt/Red
36	Fail 6	Input	Blk/Blu
11	Fail 5	Input	Blu/Blk
37	Mon 4	Output	Blk/Org
12	Mon 3	Output	Org/Blk
38	unused	No Connect	
13	unused	No Connect	
39	Dis 4	Input/Output	Blk/Brn
14	Dis 3	Input/Output	Brn/Blk
40	Vote 4	Input/Output	Blk/Slt
15	Vote 3	Input/Output	Slt/Blk
41	Rx 4	Input	Yel/Blu
16	Rx 3	Input	Blu/Yel
42	Fail 4	Input	Yel/Org
17	Fail 3	Input	Org/Yel
43	unused	No Connect	
18	Mon 7	Output	Grn/Yel
44	Mon 2	Output	Yel/Brn
19	Mon 1	Output	Brn/Yel
45	Dis 2	Input/Output	Yel/Slt
20	Dis 1	Input/Output	Slt/Yel
46	Vote 2	Input/Output	Vio/Blu
21	Vote 1	Input/Output	Blu/Vio
47	Rx 2	Input	Vio/Org
22	Rx 1	Input	Org/Vio
48	Fail 2	Input	Vio/Grn
23	Fail 1	Input	Grn/Vio
49	unused	No Connect	
24	unused	No Connect	
50	unused	No Connect	
25	unused	No Connect	

Table 10 - CIB Connector J1 Pinout in Punch Block Order

6. Mounting

Various mounting kits are available to mount the CIB module.

Mounting Kits	
Rack Mount - 4 A size modules 1 Rack Unit (1.75") High	S2-60435
Rack Mount - 2 A size modules plus 1 B size module 1 Rack Unit (1.75") High (Used to mount 2 CIBs and 1 EXB module.)	S2-60443
Wall Mount - 1 A size module	S2-60444
Digitac Mounting Kit and Cable Mounts on rear of Digitac comparator. Includes "T" ribbon cable to connect to P805.	S2-60437

Refer the reference 1, section *Mounting Options*, for physical details about mounting the CIB module.

CAUTION

Make sure that any mounting screws used to secure unit to a wall-mount bracket or Digitac Bracket do not protrude into the unit's enclosure more than 1/8 inches from the bottom surface of the unit.

Using a larger screw that touches the PC board inside the unit may damage the unit when it is powered. Doing so will void the unit's warranty.

7. Comparator Wiring Lists

This section includes wiring lists to help you connect a CIB module to a particular comparator. If you are using a comparator not shown in this section, refer to Table 9 for the pinout of connector J1 on the back of the CIB module.

NOTE: When connecting the CIB to your comparator, please follow the settings specified for jumpers E1A and E1B. Improper setting of these jumpers could result in improper operation of your comparator display system.

Wiring lists are given for the following comparators:

- TAC page 18
- Spectra TAC page 20
- Digitac page 22
- M/A-Com / Ericsson / G.E. Analog Voter page 24
- JPS SNV-12 Voter page 27
- Doug Hall 4RV/2 Voter page 30

The wiring lists tell you if the CIB J1 pin being connected is Input (I), Output (O) or Input/Output (I/O). Refer to Figure 2 for a diagram of the CIB's I/O circuitry.

Wiring lists are included for both Logical Order and Punch Block Order.

7.1 Motorola TAC Comparator

CIB J1	I/O	Wire Color	Function	RX Module Pins	TAC Signals	Notes
21	I	Blu/Vio	Vote 1	16	Selected Chan	
22	I	Org/Vio	Rx 1	5	Chan Receiving	
20	I/O	SlT/Yel	Dis 1	18	Disable Input	
23	I	Grn/Vio	Fail 1			
19	O	Brn/Yel	Mon 1	17	Monitor Input	
46	I	Vio/Blu	Vote 2	16	Selected Chan	
47	I	Vio/Org	Rx 2	5	Chan Receiving	
45	I/O	Yel/SlT	Dis 2	18	Disable Input	
48	I	Vio/Grn	Fail 2			
44	O	Yel/Brn	Mon 2	17	Monitor Input	
15	I	SlT/Blk	Vote 3	16	Selected Chan	
16	I	Blu/Yel	Rx 3	5	Chan Receiving	
14	I/O	Brn/Blk	Dis 3	18	Disable Input	
17	I	Org/Yel	Fail 3			
12	O	Org/Blk	Mon 3	17	Monitor Input	
40	I	Blk/SlT	Vote 4	16	Selected Chan	
41	I	Yel/Blu	Rx 4	5	Chan Receiving	
39	I/O	Blk/Brn	Dis 4	18	Disable Input	
42	I	Yel/Org	Fail 4	--		
37	O	Blk/Org	Mon 4	17	Monitor Input	
9	I	Brn/Red	Vote 5	16	Selected Chan	
10	I	SlT/Red	Rx 5	5	Chan Receiving	
8	I/O	Grn/Red	Dis 5	18	Disable Input	
11	I	Blu/Blk	Fail 5			
6	O	Blu/Red	Mon 5	17	Monitor Input	
34	I	Red/Brn	Vote 6	16	Selected Chan	
35	I	Red/SlT	Rx 6	5	Chan Receiving	
33	I/O	Red/Grn	Dis 6	18	Disable Input	
36	I	Blk/Blu	Fail 6			
31	O	Red/Blu	Mon 6	17	Monitor Input	
3	I	Grn/Wht	Vote 7	16	Selected Chan	
4	I	Brn/Wht	Rx 7	5	Chan Receiving	
2	I/O	Org/Wht	Dis 7	18	Disable Input	
5	I	SlT/Wht	Fail 7			
18	O	Grn/Yel	Mon 7	17	Monitor Input	
28	I	Wht/Grn	Vote 8	16	Selected Chan	
29	I	Wht/Brn	Rx 8	5	Chan Receiving	
27	I/O	Wht/Org	Dis 8	18	Disable Input	
30	I	Wht/SlT	Fail 8			
26	O	Wht/Blu	Mon 8	17	Monitor Input	
1	Gnd	Blu/Wht	Ground	24	Ground	

Table 11 - CIB to TAC Wiring List - Logical Order

Jumpers: E1A IN E1B OUT
Option Switches: 1 UP 2 DOWN

Motorola TAC Comparator

CIB J1	I/O	Wire Color	Function	RX Module Pins	TAC Signals	Notes
26	O	Wht/Blu	Mon 8	17	Monitor Input	
1	Gnd	Blu/Wht	Ground	24	Ground	
27	I/O	Wht/Org	Dis 8	18	Disable Input	
2	I/O	Org/Wht	Dis 7	18	Disable Input	
28	I	Wht/Grn	Vote 8	16	Selected Chan	
3	I	Grn/Wht	Vote 7	16	Selected Chan	
29	I	Wht/Brn	Rx 8	5	Chan Receiving	
4	I	Brn/Wht	Rx 7	5	Chan Receiving	
30	I	Wht/Slt	Fail 8			
5	I	Slt/Wht	Fail 7			
31	O	Red/Blu	Mon 6	17	Monitor Input	
6	O	Blu/Red	Mon 5	17	Monitor Input	
32			Unused			
7			Unused			
33	I/O	Red/Grn	Dis 6	18	Disable Input	
8	I/O	Grn/Red	Dis 5	18	Disable Input	
34	I	Red/Brn	Vote 6	16	Selected Chan	
9	I	Brn/Red	Vote 5	16	Selected Chan	
35	I	Red/Slt	Rx 6	5	Chan Receiving	
10	I	Slt/Red	Rx 5	5	Chan Receiving	
36	I	Blk/Blu	Fail 6			
11	I	Blu/Blk	Fail 5			
37	O	Blk/Org	Mon 4	17	Monitor Input	
12	O	Org/Blk	Mon 3	17	Monitor Input	
38			Unused			
13			Unused			
39	I/O	Blk/Brn	Dis 4	18	Disable Input	
14	I/O	Brn/Blk	Dis 3	18	Disable Input	
40	I	Blk/Slt	Vote 4	16	Selected Chan	
15	I	Slt/Blk	Vote 3	16	Selected Chan	
41	I	Yel/Blu	Rx 4	5	Chan Receiving	
16	I	Blu/Yel	Rx 3	5	Chan Receiving	
42	I	Yel/Org	Fail 4	--		
17	I	Org/Yel	Fail 3			
43			Unused			
18	O	Grn/Yel	Mon 7	17	Monitor Input	
44	O	Yel/Brn	Mon 2	17	Monitor Input	
19	O	Brn/Yel	Mon 1	17	Monitor Input	
45	I/O	Yel/Slt	Dis 2	18	Disable Input	
20	I/O	Slt/Yel	Dis 1	18	Disable Input	
46	I	Vio/Blu	Vote 2	16	Selected Chan	
21	I	Blu/Vio	Vote 1	16	Selected Chan	
47	I	Vio/Org	Rx 2	5	Chan Receiving	
22	I	Org/Vio	Rx 1	5	Chan Receiving	
48	I	Vio/Grn	Fail 2			
23	I	Grn/Vio	Fail 1			
49			Unused			
24			Unused			
50			Unused			
25			Unused			

Table 12 - CIB to TAC Wiring List -Punch Block Order

Jumpers: E1A IN E1B OUT
Option Switches: 1 UP 2 DOWN

7.2 Motorola Spectra TAC Comparator

CIB J1	I/O	Wire Color	Function	Sig Qual Mod Pins	Spectra TAC Signal	Notes
21	I/O	Blu/Vio	Vote/Mon 1	20	Vote Indicate	
22	I	Org/Vio	Rx 1	11	Unselch Indicate	
20	I/O	SlT/Yel	Dis 1	19	Module Disable	
23	I	Grn/Vio	Fail 1	23	Failed Indicate	
19	O	Brn/Yel	Mon 1			
46	I/O	Vio/Blu	Vote/Mon 2	20	Vote Indicate	
47	I	Vio/Org	Rx 2	11	Unselch Indicate	
45	I/O	Yel/SlT	Dis 2	19	Module Disable	
48	I	Vio/Grn	Fail 2	23	Failed Indicate	
44	O	Yel/Brn	Mon 2			
15	I/O	SlT/Blk	Vote/Mon 3	20	Vote Indicate	
16	I	Blu/Yel	Rx 3	11	Unselch Indicate	
14	I/O	Brn/Blk	Dis 3	19	Module Disable	
17	I	Org/Yel	Fail 3	23	Failed Indicate	
12	O	Org/Blk	Mon 3			
40	I/O	Blk/SlT	Vote/Mon 4	20	Vote Indicate	
41	I	Yel/Blu	Rx 4	11	Unselch Indicate	
39	I/O	Blk/Brn	Dis 4	19	Module Disable	
42	I	Yel/Org	Fail 4	23	Failed Indicate	
37	O	Blk/Org	Mon 4			
9	I/O	Brn/Red	Vote/Mon 5	20	Vote Indicate	
10	I	SlT/Red	Rx 5	11	Unselch Indicate	
8	I/O	Grn/Red	Dis 5	19	Module Disable	
11	I	Blu/Blk	Fail 5	23	Failed Indicate	
6	O	Blu/Red	Mon 5			
34	I/O	Red/Brn	Vote/Mon 6	20	Vote Indicate	
35	I	Red/SlT	Rx 6	11	Unselch Indicate	
33	I/O	Red/Grn	Dis 6	19	Module Disable	
36	I	Blk/Blu	Fail 6	23	Failed Indicate	
31	O	Red/Blu	Mon 6			
3	I/O	Grn/Wht	Vote/Mon 7	20	Vote Indicate	
4	I	Brn/Wht	Rx 7	11	Unselch Indicate	
2	I/O	Org/Wht	Dis 7	19	Module Disable	
5	I	SlT/Wht	Fail 7	23	Failed Indicate	
18	O	Grn/Yel	Mon 7			
28	I/O	Wht/Grn	Vote/Mon 8	20	Vote Indicate	
29	I	Wht/Brn	Rx 8	11	Unselch Indicate	
27	I/O	Wht/Org	Dis 8	19	Module Disable	
30	I	Wht/SlT	Fail 8	23	Failed Indicate	
26	O	Wht/Blu	Mon 8			
1	Gnd	Blu/Wht	Ground	1	Ground	

Table 13 - CIB to Spectra-TAC Wiring List - Logical Order

Jumpers: **E1A IN** **E1B IN**
Option Switches: **1 DOWN** **2 DOWN**

Motorola Spectra TAC Comparator

CIB J1	I/O	Wire Color	Function	Sig Qual Mod Pins	Spectra TAC Signal	Notes
26	O	Wht/Blu	Mon 8			
1	Gnd	Blu/Wht	Ground	1	Ground	
27	I/O	Wht/Org	Dis 8	19	Module Disable	
2	I/O	Org/Wht	Dis 7	19	Module Disable	
28	I/O	Wht/Grn	Vote/Mon 8	20	Vote Indicate	
3	I/O	Grn/Wht	Vote/Mon 7	20	Vote Indicate	
29	I	Wht/Brn	Rx 8	11	Unsnquch Indicate	
4	I	Brn/Wht	Rx 7	11	Unsnquch Indicate	
30	I	Wht/Slit	Fail 8	23	Failed Indicate	
5	I	Slit/Wht	Fail 7	23	Failed Indicate	
31	O	Red/Blu	Mon 6			
6	O	Blu/Red	Mon 5			
32			Unused			
7			Unused			
33	I/O	Red/Grn	Dis 6	19	Module Disable	
8	I/O	Grn/Red	Dis 5	19	Module Disable	
34	I/O	Red/Brn	Vote/Mon 6	20	Vote Indicate	
9	I/O	Brn/Red	Vote/Mon 5	20	Vote Indicate	
35	I	Red/Slit	Rx 6	11	Unsnquch Indicate	
10	I	Slit/Red	Rx 5	11	Unsnquch Indicate	
36	I	Blk/Blu	Fail 6	23	Failed Indicate	
11	I	Blu/Blk	Fail 5	23	Failed Indicate	
37	O	Blk/Org	Mon 4			
12	O	Org/Blk	Mon 3			
38			Unused			
13			Unused			
39	I/O	Blk/Brn	Dis 4	19	Module Disable	
14	I/O	Brn/Blk	Dis 3	19	Module Disable	
40	I/O	Blk/Slit	Vote/Mon 4	20	Vote Indicate	
15	I/O	Slit/Blk	Vote/Mon 3	20	Vote Indicate	
41	I	Yel/Blu	Rx 4	11	Unsnquch Indicate	
16	I	Blu/Yel	Rx 3	11	Unsnquch Indicate	
42	I	Yel/Org	Fail 4	23	Failed Indicate	
17	I	Org/Yel	Fail 3	23	Failed Indicate	
43			Unused			
18	O	Grn/Yel	Mon 7			
44	O	Yel/Brn	Mon 2			
19	O	Brn/Yel	Mon 1			
45	I/O	Yel/Slit	Dis 2	19	Module Disable	
20	I/O	Slit/Yel	Dis 1	19	Module Disable	
46	I/O	Vio/Blu	Vote/Mon 2	20	Vote Indicate	
21	I/O	Blu/Vio	Vote/Mon 1	20	Vote Indicate	
47	I	Vio/Org	Rx 2	11	Unsnquch Indicate	
22	I	Org/Vio	Rx 1	11	Unsnquch Indicate	
48	I	Vio/Grn	Fail 2	23	Failed Indicate	
23	I	Grn/Vio	Fail 1	23	Failed Indicate	
49			Unused			
24			Unused			
50			Unused			
25			Unused			

Table 14 - CIB to Spectra-TAC Wiring List - Punch Block Order

Jumpers: E1A IN E1B IN
Option Switches: 1 DOWN 2 DOWN

7.3 Motorola Digitac Comparator

CIB J1	I/O	Wire Color	Function	P805 Pins	Digitac Signals	Notes
21	I/O	Blu/Vio	Vote 1	21	Vote/Mon 1	
22	I	Org/Vio	Rx 1	22	Active Chan 1	
20	I/O	Slt/Yel	Dis 1	20	Fail/Disable 1	
23	I	Grn/Vio	Fail 1	23 *	Mode Chan 1	
19	O	Brn/Yel	Mon 1	19 *		
46	I	Vio/Blu	Vote 2	46	Vote/Mon 2	
47	I	Vio/Org	Rx 2	47	Active Chan 2	
45	I/O	Yel/Slt	Dis 2	45	Fail/Disable 2	
48	I	Vio/Grn	Fail 2	48 *	Mode Chan 2	
44	O	Yel/Brn	Mon 2	44 *		
15	I	Slt/Blk	Vote 3	15	Vote/Mon 3	
16	I	Blu/Yel	Rx 3	16	Active Chan 3	
14	I/O	Brn/Blk	Dis 3	14	Fail/Disable 3	
17	I	Org/Yel	Fail 3	17 *	Mode Chan 3	
12	O	Org/Blk	Mon 3	12 *		
40	I	Blk/Slt	Vote 4	40	Vote/Mon 4	
41	I	Yel/Blu	Rx 4	41	Active Chan 4	
39	I/O	Blk/Brn	Dis 4	39	Fail/Disable 4	
42	I	Yel/Org	Fail 4	42 *	Mode Chan 4	
37	O	Blk/Org	Mon 4	37 *		
9	I	Brn/Red	Vote 5	9	Vote/Mon 5	
10	I	Slt/Red	Rx 5	10	Active Chan 5	
8	I/O	Grn/Red	Dis 5	8	Fail/Disable 5	
11	I	Blu/Blk	Fail 5	11 *	Mode Chan 5	
6	O	Blu/Red	Mon 5	6 *		
34	I	Red/Brn	Vote 6	34	Vote/Mon 6	
35	I	Red/Slt	Rx 6	35	Active Chan 6	
33	I/O	Red/Grn	Dis 6	33	Fail/Disable 6	
36	I	Blk/Blu	Fail 6	36 *	Mode Chan 6	
31	O	Red/Blu	Mon 6	31 *		
3	I	Grn/Wht	Vote 7	3	Vote/Mon 7	
4	I	Brn/Wht	Rx 7	4	Active Chan 7	
2	I/O	Org/Wht	Dis 7	2	Fail/Disable 7	
5	I	Slt/Wht	Fail 7	5 *	Mode Chan 7	
18	O	Grn/Yel	Mon 7	18 *		E1-A must be removed to isolate this signal.
28	I	Wht/Grn	Vote 8	28	Vote/Mon 8	
29	I	Wht/Brn	Rx 8	29	Active Chan 8	
27	I/O	Wht/Org	Dis 8	27	Fail/Disable 8	
30	I	Wht/Slt	Fail 8	30 *	Mode Chan 8	
26	O	Wht/Blu	Mon 8	26 *		
1	Gnd	Blu/Wht	Ground	1	Ground	

Table 15 - CIB to Digitac Wiring List - Logical Order

Jumpers: E1A OUT E1B OUT

Option Switches: 1 DOWN 2 UP

* These pins are not used by the CIB when configured for the Digitac comparator and will not conflict with Digitac operation when connected to P805 with a 50 pin straight through cable

Motorola Digitac Comparator

CIB J1	I/O	Wire Color	Function	P805 Pins	Digitac Signals	Notes
26	O	Wht/Blu	Mon 8	26 *		
1	Gnd	Blu/Wht	Ground	1	Ground	
27	I/O	Wht/Org	Dis 8	27	Fail/Disable 8	
2	I/O	Org/Wht	Dis 7	2	Fail/Disable 7	
28	I	Wht/Grn	Vote 8	28	Vote/Mon 8	
3	I	Grn/Wht	Vote 7	3	Vote/Mon 7	
29	I	Wht/Brn	Rx 8	29	Active Chan 8	
4	I	Brn/Wht	Rx 7	4	Active Chan 7	
30	I	Wht/Slt	Fail 8	30 *	Mode Chan 8	
5	I	Slt/Wht	Fail 7	5 *	Mode Chan 7	
31	O	Red/Blu	Mon 6	31 *		
6	O	Blu/Red	Mon 5	6 *		
32			Unused			
7			Unused			
33	I/O	Red/Grn	Dis 6	33	Fail/Disable 6	
8	I/O	Grn/Red	Dis 5	8	Fail/Disable 5	
34	I	Red/Brn	Vote 6	34	Vote/Mon 6	
9	I	Brn/Red	Vote 5	9	Vote/Mon 5	
35	I	Red/Slt	Rx 6	35	Active Chan 6	
10	I	Slt/Red	Rx 5	10	Active Chan 5	
36	I	Blk/Blu	Fail 6	36 *	Mode Chan 6	
11	I	Blu/Blk	Fail 5	11 *	Mode Chan 5	
37	O	Blk/Org	Mon 4	37 *		
12	O	Org/Blk	Mon 3	12 *		
38			Unused			
13			Unused			
39	I/O	Blk/Brn	Dis 4	39	Fail/Disable 4	
14	I/O	Brn/Blk	Dis 3	14	Fail/Disable 3	
40	I	Blk/Slt	Vote 4	40	Vote/Mon 4	
15	I	Slt/Blk	Vote 3	15	Vote/Mon 3	
41	I	Yel/Blu	Rx 4	41	Active Chan 4	
16	I	Blu/Yel	Rx 3	16	Active Chan 3	
42	I	Yel/Org	Fail 4	42 *	Mode Chan 4	
17	I	Org/Yel	Fail 3	17 *	Mode Chan 3	
43			Unused			
18	O	Grn/Yel	Mon 7	18 *		<i>E1-A must be removed to isolate this signal</i>
44	O	Yel/Brn	Mon 2	44 *		
19	O	Brn/Yel	Mon 1	19 *		
45	I/O	Yel/Slt	Dis 2	45	Fail/Disable 2	
20	I/O	Slt/Yel	Dis 1	20	Fail/Disable 1	
46	I	Vio/Blu	Vote 2	46	Vote/Mon 2	
21	I/O	Blu/Vio	Vote 1	21	Vote/Mon 1	
47	I	Vio/Org	Rx 2	47	Active Chan 2	
22	I	Org/Vio	Rx 1	22	Active Chan 1	
48	I	Vio/Grn	Fail 2	48 *	Mode Chan 2	
23	I	Grn/Vio	Fail 1	23 *	Mode Chan 1	
49			Unused			
24			Unused			
50			Unused			
25			Unused			

Table 16 - CIB to Digitac Wiring List - Punch Block Order

Jumpers: E1A OUT E1B OUT

Option Switches: 1 DOWN 2 UP

* These pins are not used by the CIB when configured for the Digitac comparator and will not conflict with Digitac operation when connected to P805 with a 50 pin straight through cable

7.4 M/A-Com / Ericsson / G.E. Analog Voter

P1	I/O	Wire Color	Function	TB1-TB6 or RX Mod Pins	GE Sig. Name	Notes
21	I	Blu/Vio	Vote 1	TB ___ Pin 4	SELECT	
22	I	Org/Vio	Rx 1	TB ___ Pin 6	UNSQ	
20	I/O	Slit/Yel	Dis 1	TB ___ Pin 1	REJ SW	
23	I	Grn/Vio	Fail 1	RX Mod Pin 19 *	FAIL *	
19	O	Brn/Yel	Mon 1	TB ___ Pin 2	SEL SW	
46	I	Vio/Blu	Vote 2	TB ___ Pin 4	SELECT	
47	I	Vio/Org	Rx 2	TB ___ Pin 6	UNSQ	
45	I/O	Yel/Slit	Dis 2	TB ___ Pin 1	REJ SW	
48	I	Vio/Grn	Fail 2	RX Mod Pin 19 *	FAIL *	
44	O	Yel/Brn	Mon 2	TB ___ Pin 2	SEL SW	
15	I	Slit/Blk	Vote 3	TB ___ Pin 4	SELECT	
16	I	Blu/Yel	Rx 3	TB ___ Pin 6	UNSQ	
14	I/O	Brn/Blk	Dis 3	TB ___ Pin 1	REJ SW	
17	I	Org/Yel	Fail 3	RX Mod Pin 19 *	FAIL *	
12	O	Org/Blk	Mon 3	TB ___ Pin 2	SEL SW	
40	I	Blk/Slit	Vote 4	TB ___ Pin 4	SELECT	
41	I	Yel/Blu	Rx 4	TB ___ Pin 6	UNSQ	
39	I/O	Blk/Brn	Dis 4	TB ___ Pin 1	REJ SW	
42	I	Yel/Org	Fail 4	RX Mod Pin 19 *	FAIL *	
37	O	Blk/Org	Mon 4	TB ___ Pin 2	SEL SW	
9	I	Brn/Red	Vote 5	TB ___ Pin 4	SELECT	
10	I	Slit/Red	Rx 5	TB ___ Pin 6	UNSQ	
8	I/O	Grn/Red	Dis 5	TB ___ Pin 1	REJ SW	
11	I	Blu/Blk	Fail 5	RX Mod Pin 19 *	FAIL *	
6	O	Blu/Red	Mon 5	TB ___ Pin 2	SEL SW	
34	I	Red/Brn	Vote 6	TB ___ Pin 4	SELECT	
35	I	Red/Slit	Rx 6	TB ___ Pin 6	UNSQ	
33	I/O	Red/Grn	Dis 6	TB ___ Pin 1	REJ SW	
36	I	Blk/Blu	Fail 6	RX Mod Pin 19 *	FAIL *	
31	O	Red/Blu	Mon 6	TB ___ Pin 2	SEL SW	
3	I	Grn/Wht	Vote 7	TB ___ Pin 4	SELECT	
4	I	Brn/Wht	Rx 7	TB ___ Pin 6	UNSQ	
2	I/O	Org/Wht	Dis 7	TB ___ Pin 1	REJ SW	
5	I	Slit/Wht	Fail 7	RX Mod Pin 19 *	FAIL *	
18	O	Grn/Yel	Mon 7	TB ___ Pin 2	SEL SW	
28	I	Wht/Grn	Vote 8	TB ___ Pin 4	SELECT	
29	I	Wht/Brn	Rx 8	TB ___ Pin 6	UNSQ	
27	I/O	Wht/Org	Dis 8	TB ___ Pin 1	REJ SW	
30	I	Wht/Slit	Fail 8	RX Mod Pin 19 *	FAIL *	
26	O	Wht/Blu	Mon 8	TB ___ Pin 2	SEL SW	
1	Gnd	Blu/Wht	Ground	RX Mod Pin F/6	GRD	

Table 17 - CIB to M/A-Com / Ericsson / G.E. Analog Voter - Logical Order

Jumpers: E1A IN E1B OUT

Option Switches: 1 UP 2 DOWN

* See section 7.4.1 for a description of the receiver module modifications needed to monitor the fail signal.

M/A-Com / Ericsson / G.E. Analog Voter

P1	I/O	Wire Color	Function	TB1-TB6 or RX Mod Pins	GE Sig. Name	Notes
26	O	Wht/Blu	Mon 8	TB ___ Pin 2	SEL SW	
1	Gnd	Blu/Wht	Ground	RX Mod Pin F/6	GRD	
27	I/O	Wht/Org	Dis 8	TB ___ Pin 1	REJ SW	
2	I/O	Org/Wht	Dis 7	TB ___ Pin 1	REJ SW	
28	I	Wht/Grn	Vote 8	TB ___ Pin 4	SELECT	
3	I	Grn/Wht	Vote 7	TB ___ Pin 4	SELECT	
29	I	Wht/Brn	Rx 8	TB ___ Pin 6	UNSQ	
4	I	Brn/Wht	Rx 7	TB ___ Pin 6	UNSQ	
30	I	Wht/Sl't	Fail 8	RX Mod Pin 19 *	FAIL *	
5	I	Sl't/Wht	Fail 7	RX Mod Pin 19 *	FAIL *	
31	O	Red/Blu	Mon 6	TB ___ Pin 2	SEL SW	
6	O	Blu/Red	Mon 5	TB ___ Pin 2	SEL SW	
32			Unused			
7			Unused			
33	I/O	Red/Grn	Dis 6	TB ___ Pin 1	REJ SW	
8	I/O	Grn/Red	Dis 5	TB ___ Pin 1	REJ SW	
34	I	Red/Brn	Vote 6	TB ___ Pin 4	SELECT	
9	I	Brn/Red	Vote 5	TB ___ Pin 4	SELECT	
35	I	Red/Sl't	Rx 6	TB ___ Pin 6	UNSQ	
10	I	Sl't/Red	Rx 5	TB ___ Pin 6	UNSQ	
36	I	Blk/Blu	Fail 6	RX Mod Pin 19 *	FAIL *	
11	I	Blu/Blk	Fail 5	RX Mod Pin 19 *	FAIL *	
37	O	Blk/Org	Mon 4	TB ___ Pin 2	SEL SW	
12	O	Org/Blk	Mon 3	TB ___ Pin 2	SEL SW	
38			Unused			
13			Unused			
39	I/O	Blk/Brn	Dis 4	TB ___ Pin 1	REJ SW	
14	I/O	Brn/Blk	Dis 3	TB ___ Pin 1	REJ SW	
40	I	Blk/Sl't	Vote 4	TB ___ Pin 4	SELECT	
15	I	Sl't/Blk	Vote 3	TB ___ Pin 4	SELECT	
41	I	Yel/Blu	Rx 4	TB ___ Pin 6	UNSQ	
16	I	Blu/Yel	Rx 3	TB ___ Pin 6	UNSQ	
42	I	Yel/Org	Fail 4	RX Mod Pin 19 *	FAIL *	
17	I	Org/Yel	Fail 3	RX Mod Pin 19 *	FAIL *	
43			Unused			
18	O	Grn/Yel	Mon 7	TB ___ Pin 2	SEL SW	
44	O	Yel/Brn	Mon 2	TB ___ Pin 2	SEL SW	
19	O	Brn/Yel	Mon 1	TB ___ Pin 2	SEL SW	
45	I/O	Yel/Sl't	Dis 2	TB ___ Pin 1	REJ SW	
20	I/O	Sl't/Yel	Dis 1	TB ___ Pin 1	REJ SW	
46	I	Vio/Blu	Vote 2	TB ___ Pin 4	SELECT	
21	I	Blu/Vio	Vote 1	TB ___ Pin 4	SELECT	
47	I	Vio/Org	Rx 2	TB ___ Pin 6	UNSQ	
22	I	Org/Vio	Rx 1	TB ___ Pin 6	UNSQ	
48	I	Vio/Grn	Fail 2	RX Mod Pin 19 *	FAIL *	
23	I	Grn/Vio	Fail 1	RX Mod Pin 19 *	FAIL *	
49			Unused			
24			Unused			
50			Unused			
25			Unused			

Table 18 - CIB to M/A-Com / Ericsson / G.E. Analog Voter - Punch Block Order

Jumpers: E1A IN E1B OUT
Option Switches: 1 UP 2 DOWN

* See next section for description of modifications needed to monitor the fail signal.

7.4.1 **Voter Modifications For Receiver Module Fail Monitoring**

There is no isolated Fail signal brought out on the G.E. receiver module. The Fail signal on all modules are bussed together to provide a single Fail signal on the voter backplane. A field modification is required to bring out an isolated Fail line for each of the receiver modules. There are two ways to modify the voter to provide the isolated Fail signals: the Backplane modification and the Receiver Module modification.

7.4.1.1 ***Backplane Modification***

The backplane modification is the easiest modification. It will work with either the old or new style receiver modules. If you do not have a need for a common Fail output, you can cut the trace that ties together all the Fail/Alarm outputs on the receiver modules.

To do this, use a Dremel Tool or an Exacto knife to cut the trace on the backplane between pins 5/E on all the receiver modules. Connect the Fail line from the CIIB to pin 5/E on each module by soldering it to the backplane

7.4.1.2 ***Receiver Module Modification***

If you do need a common Fail/Alarm line, and you want to display the Fail indication through the CIB module, you will have to modify each receiver module. The S3-60355 GE Receiver Module Fail Line Kit includes a diode and wires that are used to bring out the individual Fail line. Install one modification kit for each receiver module.

Modification for Old Style Receiver Modules

The old receiver modules (19D413994G1) are transistorized and don't have ICs. Add a modification kit on each receiver module. Connect the black wire (cathode) to the collector of Q40. Connect the red wire (anode) to pin 19 of the edge connector. This may be done on the solder side of the board. Please note that the wires on the diodes in the modification kit are furnished long because the kit is intended for use with 2 types of modules. Cut each of the wires to the proper length for a neat installation.

Modification for New Style Receiver Modules

The new receiver modules (19D903175G1) use ICs. Add a modification kit on each receiver module. Connect the black wire (cathode) to the cathode of DS1 (collector of Q7). Connect the red wire (anode) to pin 19 of the edge connector. This may be done on the solder side of the board. Please note that the wires on the diodes in the modification kit are furnished long because the kit is intended for use with 2 types of modules. Cut each of the wires to the proper length for a neat installation.

7.5 JPS SNV-12 Voter

CIB J1	I/O	Wire Color	Function	Site/Voter Module	Voter Module Terminals	Voter Module Signal	Notes
21	I	Blu/Vio	Vote 1	1 / TB1	15	Voted Out	
22	I	Org/Vio	Rx 1	1 / TB1	16	Unsquench Out	
20	O	Slt/Yel	Dis 1	1 / TB1	12	Disable In	
23	I	Grn/Vio	Fail 1	1 / TB1	17	Fault Out	
19	O	Brn/Yel	Mon 1	1 / TB1	11	Select In	
46	I	Vio/Blu	Vote 2	2 / TB2	15	Voted Out	
47	I	Vio/Org	Rx 2	2 / TB2	16	Unsquench Out	
45	O	Yel/Slt	Dis 2	2 / TB2	12	Disable In	
48	I	Vio/Grn	Fail 2	2 / TB2	17	Fault Out	
44	O	Yel/Brn	Mon 2	2 / TB2	11	Select In	
15	I	Slt/Blk	Vote 3	3 / TB3	15	Voted Out	
16	I	Blu/Yel	Rx 3	3 / TB3	16	Unsquench Out	
14	O	Brn/Blk	Dis 3	3 / TB3	12	Disable In	
17	I	Org/Yel	Fail 3	3 / TB3	17	Fault Out	
12	O	Org/Blk	Mon 3	3 / TB3	11	Select In	
40	I	Blk/Slt	Vote 4	4 / TB4	15	Voted Out	
41	I	Yel/Blu	Rx 4	4 / TB4	16	Unsquench Out	
39	O	Blk/Brn	Dis 4	4 / TB4	12	Disable In	
42	I	Yel/Org	Fail 4	4 / TB4	17	Fault Out	
37	O	Blk/Org	Mon 4	4 / TB4	11	Select In	
9	I	Brn/Red	Vote 5	5 / TB5	15	Voted Out	
10	I	Slt/Red	Rx 5	5 / TB5	16	Unsquench Out	
8	O	Grn/Red	Dis 5	5 / TB5	12	Disable In	
11	I	Blu/Blk	Fail 5	5 / TB5	17	Fault Out	
6	O	Blu/Red	Mon 5	5 / TB5	11	Select In	
34	I	Red/Brn	Vote 6	6 / TB6	15	Voted Out	
35	I	Red/Slt	Rx 6	6 / TB6	16	Unsquench Out	
33	O	Red/Grn	Dis 6	6 / TB6	12	Disable In	
36	I	Blk/Blu	Fail 6	6 / TB6	17	Fault Out	
31	O	Red/Blu	Mon 6	6 / TB6	11	Select In	
3	I	Grn/Wht	Vote 7	7 / TB7	15	Voted Out	
4	I	Brn/Wht	Rx 7	7 / TB7	16	Unsquench Out	
2	O	Org/Wht	Dis 7	7 / TB7	12	Disable In	
5	I	Slt/Wht	Fail 7	7 / TB7	17	Fault Out	
18	O	Grn/Yel	Mon 7	7 / TB7	11	Select In	
28	I	Wht/Grn	Vote 8	8 / TB8	15	Voted Out	
29	I	Wht/Brn	Rx 8	8 / TB8	16	Unsquench Out	
27	O	Wht/Org	Dis 8	8 / TB8	12	Disable In	
30	I	Wht/Slt	Fail 8	8 / TB8	17	Fault Out	
26	O	Wht/Blu	Mon 8	8 / TB8	11	Select In	
1	Gnd	Blu/Wht	Ground	Any	20	Ground	

Table 19 - CIB to JPS SNV-12 Voter Wiring List - Logical Order

Jumpers: E1A IN E1B OUT
Option Switches: 1 UP 2 DOWN

JPS SNV-12 Voter

CIB J1	I/O	Wire Color	Function	Site/Voter Module	Voter Module Terminals	Voter Module Signal	Notes
26	O	Wht/Blu	Mon 8	8 / TB 8	11	Select In	
1	Gnd	Blu/Wht	Ground	Any	20	Ground	
27	O	Wht/Org	Dis 8	8 / TB 8	12	Disable In	
2	O	Org/Wht	Dis 7	7 / TB 7	12	Disable In	
28	I	Wht/Grn	Vote 8	8 / TB 8	15	Voted Out	Site Voter Module 8 (TB 8)
3	I	Grn/Wht	Vote 7	7 / TB 7	15	Voted Out	Site Voter Module 7 (TB 7)
29	I	Wht/Brn	Rx 8	8 / TB 8	16	Unsnquellch Out	
4	I	Brn/Wht	Rx 7	7 / TB 7	16	Unsnquellch Out	
30	I	Wht/Slt	Fail 8	8 / TB 8	17	Fault Out	
5	I	Slt/Wht	Fail 7	7 / TB 7	17	Fault Out	
31	O	Red/Blu	Mon 6	6 / TB 6	11	Select In	
6	O	Blu/Red	Mon 5	5 / TB 5	11	Select In	
32			Unused				
7			Unused				
33	O	Red/Grn	Dis 6	6 / TB 6	12	Disable In	
8	O	Grn/Red	Dis 5	5 / TB 5	12	Disable In	
34	I	Red/Brn	Vote 6	6 / TB 6	15	Voted Out	Site Voter Module 6 (TB 6)
9	I	Brn/Red	Vote 5	5 / TB 5	15	Voted Out	Site Voter Module 5 (TB 5)
35	I	Red/Slt	Rx 6	6 / TB 6	16	Unsnquellch Out	
10	I	Slt/Red	Rx 5	5 / TB 5	16	Unsnquellch Out	
36	I	Blk/Blu	Fail 6	6 / TB 6	17	Fault Out	
11	I	Blu/Blk	Fail 5	5 / TB 5	17	Fault Out	
37	O	Blk/Org	Mon 4	4 / TB 4	11	Select In	
12	O	Org/Blk	Mon 3	3 / TB 3	11	Select In	
38			Unused				
13			Unused				
39	O	Blk/Brn	Dis 4	4 / TB 4	12	Disable In	
14	O	Brn/Blk	Dis 3	3 / TB 3	12	Disable In	
40	I	Blk/Slt	Vote 4	4 / TB 4	15	Voted Out	Site Voter Module 4 (TB 4)
15	I	Slt/Blk	Vote 3	3 / TB 3	15	Voted Out	Site Voter Module 3 (TB 3)
41	I	Yel/Blu	Rx 4	4 / TB 4	16	Unsnquellch Out	
16	I	Blu/Yel	Rx 3	3 / TB 3	16	Unsnquellch Out	
42	I	Yel/Org	Fail 4	4 / TB 4	17	Fault Out	
17	I	Org/Yel	Fail 3	3 / TB 3	17	Fault Out	
43			Unused				
18	O	Grn/Yel	Mon 7	7 / TB 7	11	Select In	
44	O	Yel/Brn	Mon 2	2 / TB 2	11	Select In	
19	O	Brn/Yel	Mon 1	1 / TB 1	11	Select In	
45	O	Yel/Slt	Dis 2	2 / TB 2	12	Disable In	
20	O	Slt/Yel	Dis 1	1 / TB 1	12	Disable In	
46	I	Vio/Blu	Vote 2	2 / TB 2	15	Voted Out	Site Voter Module 2 (TB 2)
21	I	Blu/Vio	Vote 1	1 / TB 1	15	Voted Out	Site Voter Module 1 (TB 1)
47	I	Vio/Org	Rx 2	2 / TB 2	16	Unsnquellch Out	
22	I	Org/Vio	Rx 1	1 / TB 1	16	Unsnquellch Out	
48	I	Vio/Grn	Fail 2	2 / TB 2	17	Fault Out	
23	I	Grn/Vio	Fail 1	1 / TB 1	17	Fault Out	
49			Unused				
24			Unused				
50			Unused				
25			Unused				

Table 20 - CIB to JPS SNV-12 Voter Wiring List - Punch Block Order

Jumpers: E1A IN E1B OUT
Option Switches: 1 UP 2 DOWN

7.5.1

JPS Voter Modifications for Monitoring Voted Out using Channel Select In

The JPS SNV-12 Voters with firmware version 1.08 or lower do not pull the Vote Out line to ground when a receiver channel is selected externally through the Select In lines (terminal 11). the Voted Out line goes low only when the SNV-12 votes the Receiver through the standard voting process. Votes are not indicated due to a force select input.

To get a “VOTE” indication when force-voting (force selecting) a receiver site, simply connect a standard diode (type 1N914 or similar) to the SNV-12 voter module as shown in Table 21. This modification will allow the CIB module to monitor the Voted Out signal when a receiver site is selected externally via the Select In terminal. Do a modification for each voter module used with a CIB.

SNV-12 Pin	Function	DIODE
11	SELECT	CATHODE
15	VOTED OUT	ANODE

Table 21 - Diode Connection for Force-Vote Monitoring on JPS SNV-12

7.6 Doug Hall 4RV/2 Voter

CIB J1	I/O	Wire Color	Function	4RV/2 Voter Module Edge Pins	4RV/2 Signal	Notes
21	I	Blu/Vio	Voted 1	Module 1 Pin 18	Voted Out A	4RV/2 #1
22	I	Org/Vio	Rx 1	Module 1 Pin V	COR A	
20	I/O	SlT/Yel	Dis 1	Module 1 Pin X	Disable A	
23	I	Grn/Vio	Fail 1			
19	O	Brn/Yel	Mon 1	Module 1 Pin 8	Select A	
46	I	Vio/Blu	Voted 2	Module 1 Pin 17	Voted Out B	4RV/2 #1
47	I	Vio/Org	Rx 2	Module 1 Pin U	COR B	
45	I/O	Yel/SlT	Dis 2	Module 1 Pin W	Disable B	
48	I	Vio/Grn	Fail 2			
44	O	Yel/Brn	Mon 2	Module 1 Pin 7	Select B	
15	I	SlT/Blk	Voted 3	Module 1 Pin 20	Voted Out C	4RV/2 #1
16	I	Blu/Yel	Rx 3	Module 1 Pin 16	COR C	
14	I/O	Brn/Blk	Dis 3	Module 1 Pin S	Disable C	
17	I	Org/Yel	Fail 3			
12	O	Org/Blk	Mon 3	Module 1 Pin 13	Select C	
40	I	Blk/SlT	Voted 4	Module 1 Pin 19	Voted Out D	4RV/2 #1
41	I	Yel/Blu	Rx 4	Module 1 Pin 15	COR D	
39	I/O	Blk/Brn	Dis 4	Module 1 Pin T	Disable D	
42	I	Yel/Org	Fail 4			
37	O	Blk/Org	Mon 4	Module 1 Pin 14	Select D	
9	I	Brn/Red	Voted 5	Module 2 Pin 18	Voted Out A	4RV/2 #2
10	I	SlT/Red	Rx 5	Module 2 Pin V	COR A	
8	I/O	Grn/Red	Dis 5	Module 2 Pin X	Disable A	
11	I	Blu/Blk	Fail 5			
6	O	Blu/Red	Mon 5	Module 2 Pin 8	Select A	
34	I	Red/Brn	Voted 6	Module 2 Pin 17	Voted Out B	4RV/2 #2
35	I	Red/SlT	Rx 6	Module 2 Pin U	COR B	
33	I/O	Red/Grn	Dis 6	Module 2 Pin W	Disable B	
36	I	Blk/Blu	Fail 6			
31	O	Red/Blu	Mon 6	Module 2 Pin 7	Select B	
3	I	Grn/Wht	Voted 7	Module 2 Pin 20	Voted Out C	4RV/2 #2
4	I	Brn/Wht	Rx 7	Module 2 Pin 16	COR C	
2	I/O	Org/Wht	Dis 7	Module 2 Pin S	Disable C	
5	I	SlT/Wht	Fail 7			
18	O	Grn/Yel	Mon 7	Module 2 Pin 13	Select C	
28	I	Wht/Grn	Voted 8	Module 2 Pin 19	Voted Out D	4RV/2 #2
29	I	Wht/Brn	Rx 8	Module 2 Pin 15	COR D	
27	I/O	Wht/Org	Dis 8	Module 2 Pin T	Disable D	
30	I	Wht/SlT	Fail 8			
26	O	Wht/Blu	Mon 8	Module 2 Pin 14	Select D	
1	Gnd	Blu/Wht	Ground	22	Ground	

Table 22 - CIB to Doug Hall 4RV/2 Voter Wiring List - Logical Order

Jumpers: **E1A IN** **E1B OUT**
Option Switches: **1 UP** **2 DOWN**

Doug Hall 4RV/2 Voter

CIB		Wire		4RV/2 Voter	4RV/2	
J1	I/O	Color	Function	Module	Signal	Notes
				Edge Pins		
26	O	Wht/Blu	Mon 8	Module 2 Pin 14	Select D	
1	Gnd	Blu/Wht	Ground	Module 1 Pin 22	Ground	
27	I/O	Wht/Org	Dis 8	Module 2 Pin T	Disable D	
2	I/O	Org/Wht	Dis 7	Module 2 Pin S	Disable C	
28	I	Wht/Grn	Voted 8	Module 2 Pin 19	Voted Out D	4RV/2 #2
3	I	Grn/Wht	Voted 7	Module 2 Pin 20	Voted Out C	4RV/2 #2
29	I	Wht/Brn	Rx 8	Module 2 Pin 15	COR D	
4	I	Brn/Wht	Rx 7	Module 2 Pin 16	COR C	
30	I	Wht/Slt	Fail 8			
5	I	Slt/Wht	Fail 7			
31	O	Red/Blu	Mon 6	Module 2 Pin 7	Select B	
6	O	Blu/Red	Mon 5	Module 2 Pin 8	Select A	
32			Unused			
7			Unused			
33	I/O	Red/Grn	Dis 6	Module 2 Pin W	Disable B	
8	I/O	Grn/Red	Dis 5	Module 2 Pin X	Disable A	
34	I	Red/Brn	Voted 6	Module 2 Pin 17	Voted Out B	4RV/2 #2
9	I	Brn/Red	Voted 5	Module 2 Pin 18	Voted Out A	4RV/2 #2
35	I	Red/Slt	Rx 6	Module 2 Pin U	COR B	
10	I	Slt/Red	Rx 5	Module 2 Pin V	COR A	
36	I	Blk/Blu	Fail 6			
11	I	Blu/Blk	Fail 5			
37	O	Blk/Org	Mon 4	Module 1 Pin 14	Select D	
12	O	Org/Blk	Mon 3	Module 1 Pin 13	Select C	
38			Unused			
13			Unused			
39	I/O	Blk/Brn	Dis 4	Module 1 Pin T	Disable D	
14	I/O	Brn/Blk	Dis 3	Module 1 Pin S	Disable C	
40	I	Blk/Slt	Voted 4	Module 1 Pin 19	Voted Out D	4RV/2 #1
15	I	Slt/Blk	Voted 3	Module 1 Pin 20	Voted Out C	4RV/2 #1
41	I	Yel/Blu	Rx 4	Module 1 Pin 15	COR D	
16	I	Blu/Yel	Rx 3	Module 1 Pin 16	COR C	
42	I	Yel/Org	Fail 4			
17	I	Org/Yel	Fail 3			
43			Unused			
18	O	Grn/Yel	Mon 7	Module 2 Pin 13	Select C	
44	O	Yel/Brn	Mon 2	Module 1 Pin 7	Select B	
19	O	Brn/Yel	Mon 1	Module 1 Pin 8	Select A	
45	I/O	Yel/Slt	Dis 2	Module 1 Pin W	Disable B	
20	I/O	Slt/Yel	Dis 1	Module 1 Pin X	Disable A	
46	I	Vio/Blu	Voted 2	Module 1 Pin 17	Voted Out B	4RV/2 #1
21	I	Blu/Vio	Voted 1	Module 1 Pin 18	Voted Out A	4RV/2 #1
47	I	Vio/Org	Rx 2	Module 1 Pin U	COR B	
22	I	Org/Vio	Rx 1	Module 1 Pin V	COR A	
48	I	Vio/Grn	Fail 2			
23	I	Grn/Vio	Fail 1			
49			Unused			
24			Unused			
50			Unused			
25			Unused			

Table 23 - CIB to Doug Hall 4RV/2 Voter Wiring List - Punch Block Order

Jumpers: **E1A IN** **E1B OUT**
Option Switches: **1 UP** **2 DOWN**

8. Module Error Codes

This section lists all CIB specific module error codes that can be displayed by a user interface (such as a PC's display running MCNRCD).

Error Code	Description
80	The CIB is setup for transmitter monitoring and control (OPTION switch 3 is UP) but the CIB is not communicating with the TIB module. Verify that the TIB is connected to the MCN network and that it is properly configured to operate with this CIB.

9. Troubleshooting

This table is a list of troubleshooting tips specific to the CIB module. For additional troubleshooting tips, refer to the troubleshooting section found in the *Monitoring and Control Network System Manual*, reference 1.

Due to the high percentage of surface-mount components, the CIB is treated as a field replaceable unit. If any system problems are the result of a malfunctioning CIB unit, the entire unit must be replaced and returned for repair.

PROBLEM	CAUSE
<p>Transmitter steering information is not displayed on the user interface</p> <p style="text-align: center;">OR</p> <p>The active transmitter cannot be selected from the user interface</p>	<p>Verify that the CIB's OPTION switch 3 is in the UP position to enable transmitter status monitoring and control. If not, set the switch UP and reset the CIB.</p> <p>Refer to the TIB module hardware reference manual to verify that the TIB is setup correctly.</p>
<p>CIB Indication is Erratic</p>	<p>CIB is set for Transmitter Indication and a TIB unit is not connected.</p> <p>Either connect a TIB unit (and address it for the CIB address and its own address) or switch the CIB's Option 3 Switch DOWN and reset the CIB.</p>
<p>Data from CIB changes, when comparator lines are static</p>	<p>For instance, one CIB may say a receiver is Voted, while the other says it is Disabled. You will see the indication change between Voted and Disabled.</p> <p>You probably have multiple CIBs programmed for the same Group/Module address. Reset the CIB addresses and reset the appropriate CIBs.</p>
<p>The ACT LED on the CIB is off</p>	<p>This is a normal condition if there is no HIB or IIB accessing the CIB at any given time.</p>
<p>Fail or Error indication on PC when Digitac comparator votes in Coded mode</p>	<p>Improper settings on Option Switches. Re-set switches for Digitac: SW 1 Down SW 2 Up and reset the CIB module. See Section 3.7, Operation With a Digitac Comparator for more details.</p>

