

MCN MCN RYB-8 Relay Board

Hardware Manual

S2-60657-100

CFI Products Inc.  

Standard Limited Hardware Warranty

LIMITED WARRANTY. Equipment manufactured by CTI Products, Inc. is warranted to be free from defects in material and workmanship for a period of ONE (1) YEAR from date of shipment to original purchaser. Under this warranty, our obligation is limited to repairing or replacing any equipment proved to be defective by our inspection within one year of sale to the original purchaser. This warranty shall not apply to equipment which has been repaired outside our plant in any way, so as to, in the judgment of CTI Products, Inc. affect its stability or reliability, nor which has been operated in a manner exceeding its specifications, nor which has been altered, defaced, or damaged by lightning.

CUSTOMER REMEDIES. In the event of a defect, malfunction, or failure to conform to specifications established by the seller during the period shown, the customer shall call CTI Products, Inc. to obtain a Return Authorization Number and return the product or module, shipping and insurance prepaid. CTI Products, Inc., will then at its option, either repair or replace the product or module and return it, shipping prepaid, or refund the purchase price thereof. On-site labor at the purchaser's location is not included in this warranty.

EQUIPMENT NOT MANUFACTURED BY CTI Products, Inc. Equipment not manufactured by CTI Products, Inc. is excluded from this warranty, but is subject to the warranty provided by its manufacturer, a copy of which will be supplied to you upon specific written request.

NO OTHER WARRANTIES. The foregoing constitutes the sole and exclusive remedy of the buyer and exclusive liability of CTI Products, Inc., AND IS IN LIEU OF ANY AND ALL OTHER WARRANTIES EXPRESSED OR IMPLIED OR STATUTORY AS TO MERCHANTABILITY, FITNESS FOR PURPOSE SOLD, DESCRIPTION, QUALITY, PRODUCTIVENESS OR ANY OTHER MATTER.

NO LIABILITY FOR CONSEQUENTIAL DAMAGES. WITHOUT LIMITING THE FOREGOING, IN NO EVENT SHALL CTI PRODUCTS, INC. OR ITS SUPPLIERS BE LIABLE FOR ANY DAMAGES WHATSOEVER (INCLUDING, WITHOUT LIMITATION, SPECIAL, INCIDENTAL OR CONSEQUENTIAL DAMAGES OR FOR LOSS OF BUSINESS PROFITS, BUSINESS INTERRUPTION, LOSS OF BUSINESS INFORMATION, OR OTHER PECUNIARY LOSS) ARISING OUT OF THE USE OF OR INABILITY TO USE CTI PRODUCTS, INC. EQUIPMENT BY PURCHASER OR OTHER THIRD PARTY, WHETHER UNDER THEORY OF CONTRACT, TORT (INCLUDING NEGLIGENCE), INDEMNITY, PRODUCT LIABILITY OR OTHERWISE, EVEN IF CTI PRODUCTS, INC. HAS BEEN ADVISED OF THE POSSIBILITY OF SUCH DAMAGES OR LOSSES. IN NO EVENT SHALL CTI PRODUCTS, INC.'S, LIABILITY EXCEED THE TOTAL AMOUNT PAID BY PURCHASER FOR THE EQUIPMENT GIVING RISE TO SUCH LIABILITY.

CTI Products, Inc.
1211 W. Sharon Rd.
Cincinnati, OH 45240

If you have questions about this equipment, call us at:
(513) 595-5900. (8:30 to 5:00 Eastern)

Information contained in this document is subject to change without notice and does not represent a commitment on the part of CTI Products, Inc.

No part of this manual may be reproduced or transmitted in any form or by any means, electronic or mechanical, including photocopying and recording, for any purpose without the written permission of CTI Products, Inc.

Copyright 1996, CTI Products, Inc. All rights reserved.

MCN is a trademark of CTI Products, Inc. Other trademarks referenced are properties of their respective owners.

1. INTRODUCTION.....1

1.1 RELATED DOCUMENTS 1

2. CIRCUIT DESCRIPTION2

2.1 RELAY CONTROL INPUTS E1-E8 “B” SIDE2

2.2 SUB-CATEGORY JUMPERS E1-E8 “A” SIDE3

2.3 ADJACENT RELAY DRIVE JUMPERS E17-E23.....3

2.4 600 OHM TERMINATION JUMPERS E9-E164

3. JUMPER LIST5

3.1 POWER INPUT -- TB15

3.2 RELAY OUTPUT CONNECTIONS -- J16

3.3 RELAY INPUT CONNECTIONS -- J2.....7

4. MOUNTING AND CABLING9

5. SPECIFICATIONS11

6. SCHEMATIC12

7. BOARD LAYOUT.....13

This page intentionally left blank

1. Introduction

The MCN-RYB-8 board is a relay board accessory to the MCN Monitoring and Control Network product family.

The MCN-RYB-8 board has the following features:

- (8) DPDT Relays (Configured to switch circuit pairs).
- Hi-reliability long-life sealed relays.
- Relays rated for low-level (dry circuit) audio switching, up to 2A.
- Selectable 600 Ohm terminations for the Normally Open, Normally Closed, or Common circuits (may be de-selected).
- LEDs to indicate which relays are active.
- Control Connector (relay coil inputs) which is pin-compatible with the MCN IOB modules.
- 25-pair telco connectors used for control inputs and relay outputs.
- Jumpers to control adjacent relays.
- Jumpers for Sub-Category strapping for MCNRCD variable status text messages.
- Optional EIA 19" rack-mount panel available for mounting (4) MCN-RYB-8 boards.

Part Number	Description
S3-60644	Basic board with no jumpers installed
S2-60694	Board with standard jumpers installed
	E1-E8: B1 installed (I/O Line 1 controls relays)
	B4 installed (Spare sub-category jumper, parked)
	E9-E16: (2) jumpers installed in park position
	(600 Ohm Termination de-selected)
S2-XXXXX	Board with custom jumpering

Note: The MCN RYB-8 Relay board is pin-compatible with the IOB module and is fully supported for operation with it. Although it is also pin-compatible with the CIB Comparator Interface Module (in Spectra-TAC mode only), it is not supported for use with CIB modules. References are made within this document to the CIB Comparator Interface Module only for completeness, especially with the MCNRCD PC Software.

1.1 Related Documents

1. MCN IOB Input/Output Control Module
Part Number S2-60630
2. MCN System Manual
Part Number S2-60425
3. MCN Remote Comparator Display (MCNRCD) Manual
Part Number S2-60428

2. Circuit Description

The MCN-RYB-8 board has 8 identical circuits. The following will describe the first such circuit.

Relay K1 has the following I/O bits associated with it:

J2 Pin	Relay	I/O Bit	Relay Board Function	CIB Module Signal	IOB Mode 1 Signal
21	1	1	Input/Output	VOTE 1	Input/Output 1
22	1	2	Output	RECEIVE 1	input 1
20	1	3	Input/Output	DISABLE 1	Input/Output 9
23	1	4	Output	FAIL 1	input 9

I/O bits 1 or 3 can be used as inputs to drive the coil of the relay (see Figure 1).

2.1 Relay Control Inputs E1-E8 "B" Side

Each relay has its own jumper block (E1-E8) to select the input that will drive the relay coil. Each relay can be controlled from either I/O bit 1 or 3 associated with it, depending upon the position of the B1 or B3 jumper in jumper blocks E1-E8. The following table shows the jumper configuration for relay K1:

J2 Pin	I/O Bit	Jumper
21	1	E1-B1 In (Default)
20	3	E1-B3 In

Only one jumper (E1-B1 or E1-B3) should be installed at a time.

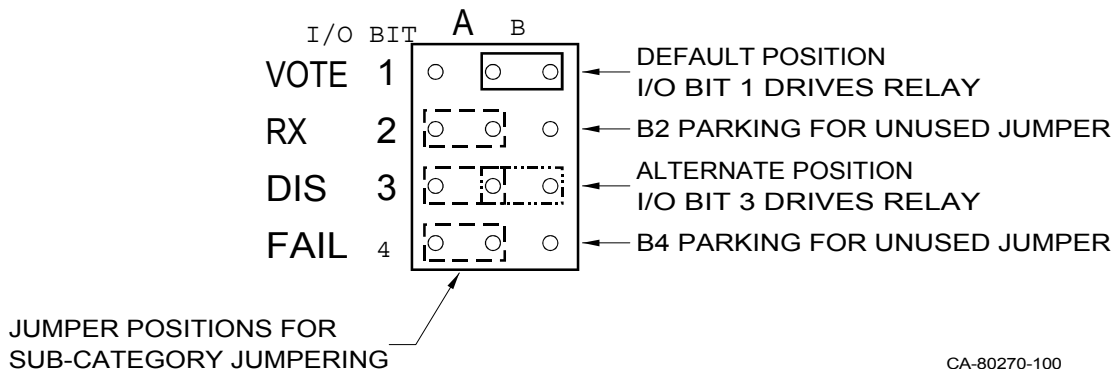

Figure 1 Input Jumpering E1-E8

Positions B2 and B4 can be used to "park" unused jumpers.

2.2 Sub-Category Jumpers E1-E8 “A” Side

When you use the MCN Relay Board with an MCN IOB module and the MCNRCD PC Software, you can use the “A” side of jumper blocks E1 through E8 to provide static sub-category status text selections. This will allow you to specify different status text messages (On/Off, Up/Down, Main/Standby, etc. as defined in the MCNRCD.CFG file) for different relays on the MCN-RYB-8 board.

For relay K1, the jumpering is shown in Table 1:

J2 Pin	Relay	I/O Bit	Jumper	CIB Signal	IOB Mode 1 Signal	MCNRCD Bit Weight
21	1	1	E1-A1 In	VOTE 1	Input/Output 1	1
22	1	2	E1-A2 In	RECEIVE 1	input 1	04
20	1	3	E1-A3 In	DISABLE 1	Input/Output 9	10
23	1	4	E1-A4 In	FAIL 1	input 9	40

Table 1 - Sub-Category Jumpers

Since I/O bit 1 is normally used to control the relay, I/O bits 2-4 are available for sub-category selection. Up to (8) sub-categories can be configured with these 3 bits. When a jumper is inserted, the bit is active. See the MCNRCD Software Manual and IOB hardware manual for more details on sub-categories.

2.3 Adjacent Relay Drive Jumpers E17-E23

In some applications you may need to drive two relays from the same input signal. You can use jumpers E17-E23 to connect a relay's coil to an adjacent relay's coil.

E17 jumpers the coils for relays 1 & 2 together. E18 jumpers relays 2 & 3, and so on.

Caution

When you insert the Adjacent Relay Drive jumpers (E17-E23), be sure that you have only one input active (E1-E8 "B" side) for each set of relays that are connected together.

These jumpers are normally not installed from the factory, unless a custom configuration is ordered.

2.4 600 Ohm Termination Jumpers E9-E16

A selectable 600 Ohm termination is available for each relay. The termination is used in some telephone line applications when you need to terminate an unused phone line. Jumper blocks E9 to E16 control the terminations. You can terminate the Normally Open, Normally Closed, or Common pair as shown in Table 2 and Figure 2

600 Ohm Termination	E9-E16 Jumpers Installed
None	None (or insert in "Park" positions)
Common Pair	A1 & B1
Normally Open Pair	A2 & B2
Normally Closed Pair	A4 & B4

Table 2 - 600 Ohm Termination Jumpering

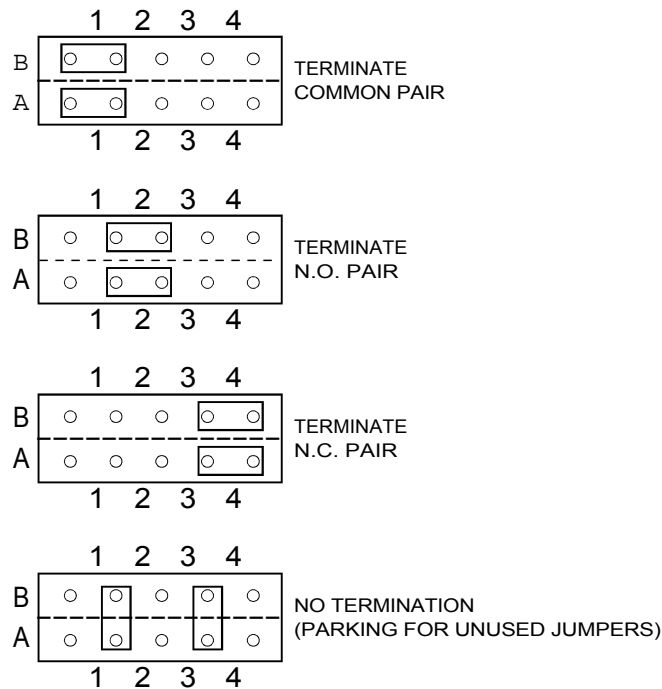

CA-80272-100

Figure 2 600 Ohm Termination Jumpering E9-E16

3. Jumper List

Jumper	Controls Relay	Description
E1	1	Input Select (B1 & B3) and Sub-Category Jumpering (A1-A4)
E2	2	Input Select (B1 & B3) and Sub-Category Jumpering (A1-A4)
E3	3	Input Select (B1 & B3) and Sub-Category Jumpering (A1-A4)
E4	4	Input Select (B1 & B3) and Sub-Category Jumpering (A1-A4)
E5	5	Input Select (B1 & B3) and Sub-Category Jumpering (A1-A4)
E6	6	Input Select (B1 & B3) and Sub-Category Jumpering (A1-A4)
E7	7	Input Select (B1 & B3) and Sub-Category Jumpering (A1-A4)
E8	8	Input Select (B1 & B3) and Sub-Category Jumpering (A1-A4)
E9	1	600 Ohm Termination Selection
E10	2	600 Ohm Termination Selection
E11	3	600 Ohm Termination Selection
E12	4	600 Ohm Termination Selection
E13	5	600 Ohm Termination Selection
E14	6	600 Ohm Termination Selection
E15	7	600 Ohm Termination Selection
E16	8	600 Ohm Termination Selection
E17	1 & 2	Adjacent relay coil selection--Connects relay coils 1 & 2
E18	2 & 3	Adjacent relay coil selection--Connects relay coils 2 & 3
E19	3 & 4	Adjacent relay coil selection--Connects relay coils 3 & 4
E20	4 & 5	Adjacent relay coil selection--Connects relay coils 4 & 5
E21	5 & 6	Adjacent relay coil selection--Connects relay coils 5 & 6
E22	6 & 7	Adjacent relay coil selection--Connects relay coils 6 & 7
E23	7 & 8	Adjacent relay coil selection--Connects relay coils 7 & 8

Table 3 - Jumper Block List

3.1 Power Input -- TB1

The board requires 12V external power at 704 mA. Power is applied through screw terminal block TB1 as shown in Table 4.

TB1 Pin	Function
1	+12V
2	+12V (can be used to daisy-chain power)
3	Ground
4	Ground (can be used to daisy-chain power)

Table 4 - Power Connections TB1

3.2 Relay Output Connections -- J1

The relay output connections appear on a 50-pin female micro-ribbon telco style connector, J1. The pinouts are as follows:

J1 Pin	Function
26	K1 Tip Common
1	K1 Ring Common
27	K1 Tip Normally Open (N.O.)
2	K1 Ring Normally Open (N.O.)
28	K1 Tip Normally Closed (N.C.)
3	K1 Ring Normally Closed (N.C.)
29	K2 Tip Common
4	K2 Ring Common
30	K2 Tip Normally Open (N.O.)
5	K2 Ring Normally Open (N.O.)
31	K2 Tip Normally Closed (N.C.)
6	K2 Ring Normally Closed (N.C.)
32	K3 Tip Common
7	K3 Ring Common
33	K3 Tip Normally Open (N.O.)
8	K3 Ring Normally Open (N.O.)
34	K3 Tip Normally Closed (N.C.)
9	K3 Ring Normally Closed (N.C.)
35	K4 Tip Common
10	K4 Ring Common
36	K4 Tip Normally Open (N.O.)
11	K4 Ring Normally Open (N.O.)
37	K4 Tip Normally Closed (N.C.)
12	K4 Ring Normally Closed (N.C.)
38	K5 Tip Common
13	K5 Ring Common
39	K5 Tip Normally Open (N.O.)
14	K5 Ring Normally Open (N.O.)
40	K5 Tip Normally Closed (N.C.)
15	K5 Ring Normally Closed (N.C.)
41	K6 Tip Common
16	K6 Ring Common
42	K6 Tip Normally Open (N.O.)
17	K6 Ring Normally Open (N.O.)
43	K6 Tip Normally Closed (N.C.)
18	K6 Ring Normally Closed (N.C.)
44	K7 Tip Common
19	K7 Ring Common
45	K7 Tip Normally Open (N.O.)
20	K7 Ring Normally Open (N.O.)
46	K7 Tip Normally Closed (N.C.)
21	K7 Ring Normally Closed (N.C.)
47	K8 Tip Common
22	K8 Ring Common
48	K8 Tip Normally Open (N.O.)
23	K8 Ring Normally Open (N.O.)
49	K8 Tip Normally Closed (N.C.)
24	K8 Ring Normally Closed (N.C.)
50	No Connection
25	No Connection

Table 5 - J1 Relay Contact Pinout

3.3 Relay Input Connections -- J2

The relay input connections appear on a 50-pin female micro-ribbon telco style connector, J2. The relay input connector is laid out to match the MCN IOB module pin-for-pin. J2 can be connected to the IOB module directly through a 25-pair straight-through male to male cable.

Since the MCN CIB module was originally set up to match the Digitac P805 pinout, the signals are a bit scrambled. For convenience, the pinouts are as shown in two tables, the first sorted by relay and function, and the second sorted by pin number. The corresponding signal names for the CIB and IOB modules are also shown.

J2 Pin	Relay	I/O Bit	Relay Board Function	CIB Module Signal	IOB Mode 1 Signal
21	1	1	Input/Output	VOTE 1	Input/Output 1
22	1	2	Output	RECEIVE 1	Input 1
20	1	3	Input/Output	DISABLE 1	Input/Output 9
23	1	4	Output	FAIL 1	Input 9
46	2	1	Input/Output	VOTE 2	Input/Output 2
47	2	2	Output	RECEIVE 2	Input 2
45	2	3	Input/Output	DISABLE 2	Input/Output 10
48	2	4	Output	FAIL 2	Input 10
15	3	1	Input/Output	VOTE 3	Input/Output 3
16	3	2	Output	RECEIVE 3	Input 3
14	3	3	Input/Output	DISABLE 3	Input/Output 11
17	3	4	Output	FAIL 3	Input 11
40	4	1	Input/Output	VOTE 4	Input/Output 4
41	4	2	Output	RECEIVE 4	Input 4
39	4	3	Input/Output	DISABLE 4	Input/Output 12
42	4	4	Output	FAIL 4	Input 12
9	5	1	Input/Output	VOTE 5	Input/Output 5
10	5	2	Output	RECEIVE 5	Input 5
8	5	3	Input/Output	DISABLE 5	Input/Output 13
11	5	4	Output	FAIL 5	Input 13
34	6	1	Input/Output	VOTE 6	Input/Output 6
35	6	2	Output	RECEIVE 6	Input 6
33	6	3	Input/Output	DISABLE 6	Input/Output 14
36	6	4	Output	FAIL 6	Input 14
3	7	1	Input/Output	VOTE 7	Input/Output 7
4	7	2	Output	RECEIVE 7	Input 7
2	7	3	Input/Output	DISABLE 7	Input/Output 15
5	7	4	Output	FAIL 7	Input 15
28	8	1	Input/Output	VOTE 8	Input/Output 8
29	8	2	Output	RECEIVE 8	Input 8
27	8	3	Input/Output	DISABLE 8	Input/Output 16
30	8	4	Output	FAIL 8	Input 16
1	Common		Ground	Ground	Ground

Table 6 - Relay Inputs Connector J2 Pinout -- Sorted by Relay & Function

J2 Pin	Relay	I/O Bit	Relay Board Function	CIB Module Signal	IOB Mode 1 Signal
26					
1	Common		Ground	Ground	Ground
27	8	3	Input/Output	DISABLE 8	Input/Output 16
2	7	3	Input/Output	DISABLE 7	Input/Output 15
28	8	1	Input/Output	VOTE 8	Input/Output 8
3	7	1	Input/Output	VOTE 7	Input/Output 7
29	8	2	Output	RECEIVE 8	Input 8
4	7	2	Output	RECEIVE 7	Input 7
30	8	4	Output	FAIL 8	Input 16
5	7	4	Output	FAIL 7	Input 15
31					
6					
32					
7					
33	6	3	Input/Output	DISABLE 6	Input/Output 14
8	5	3	Input/Output	DISABLE 5	Input/Output 13
34	6	1	Input/Output	VOTE 6	Input/Output 6
9	5	1	Input/Output	VOTE 5	Input/Output 5
35	6	2	Output	RECEIVE 6	Input 6
10	5	2	Output	RECEIVE 5	Input 5
36	6	4	Output	FAIL 6	Input 14
11	5	4	Output	FAIL 5	Input 13
37					
12					
38					
13					
39	4	3	Input/Output	DISABLE 4	Input/Output 12
14	3	3	Input/Output	DISABLE 3	Input/Output 11
40	4	1	Input/Output	VOTE 4	Input/Output 4
15	3	1	Input/Output	VOTE 3	Input/Output 3
41	4	2	Output	RECEIVE 4	Input 4
16	3	2	Output	RECEIVE 3	Input 3
42	4	4	Output	FAIL 4	Input 12
17	3	4	Output	FAIL 3	Input 11
43					
18					
44					
19					
45	2	3	Input/Output	DISABLE 2	Input/Output 10
20	1	3	Input/Output	DISABLE 1	Input/Output 9
46	2	1	Input/Output	VOTE 2	Input/Output 2
21	1	1	Input/Output	VOTE 1	Input/Output 1
47	2	2	Output	RECEIVE 2	Input 2
22	1	2	Output	RECEIVE 1	Input 1
48	2	4	Output	FAIL 2	Input 10
23	1	4	Output	FAIL 1	Input 9
49					
24					
50					
25					

Table 7 - Relay Inputs Connector J2 Pinout -- Sorted by Pin Number

4. Mounting and Cabling

The following options are available for the MCN-RYB-8 relay board:

- S2-60646 Relay Board quad rack-mounting panel
- S2-60645 Ribbon Cable assembly for CIB or IOB to relay board (25-pair)

The Mounting Panel mounts in an EIA 19" rack. It can hold 4 MCN RYB-8 boards. It has snap-in standoffs for board mounting and includes tie-points for use with cable ties. It is 10.5" high (6 Rack Units).

Figure 3 shows a back view of the Mounting Panel with the boards mounted. It also shows the ribbon cable used to connect the relay boards with an IOB or CIB module.

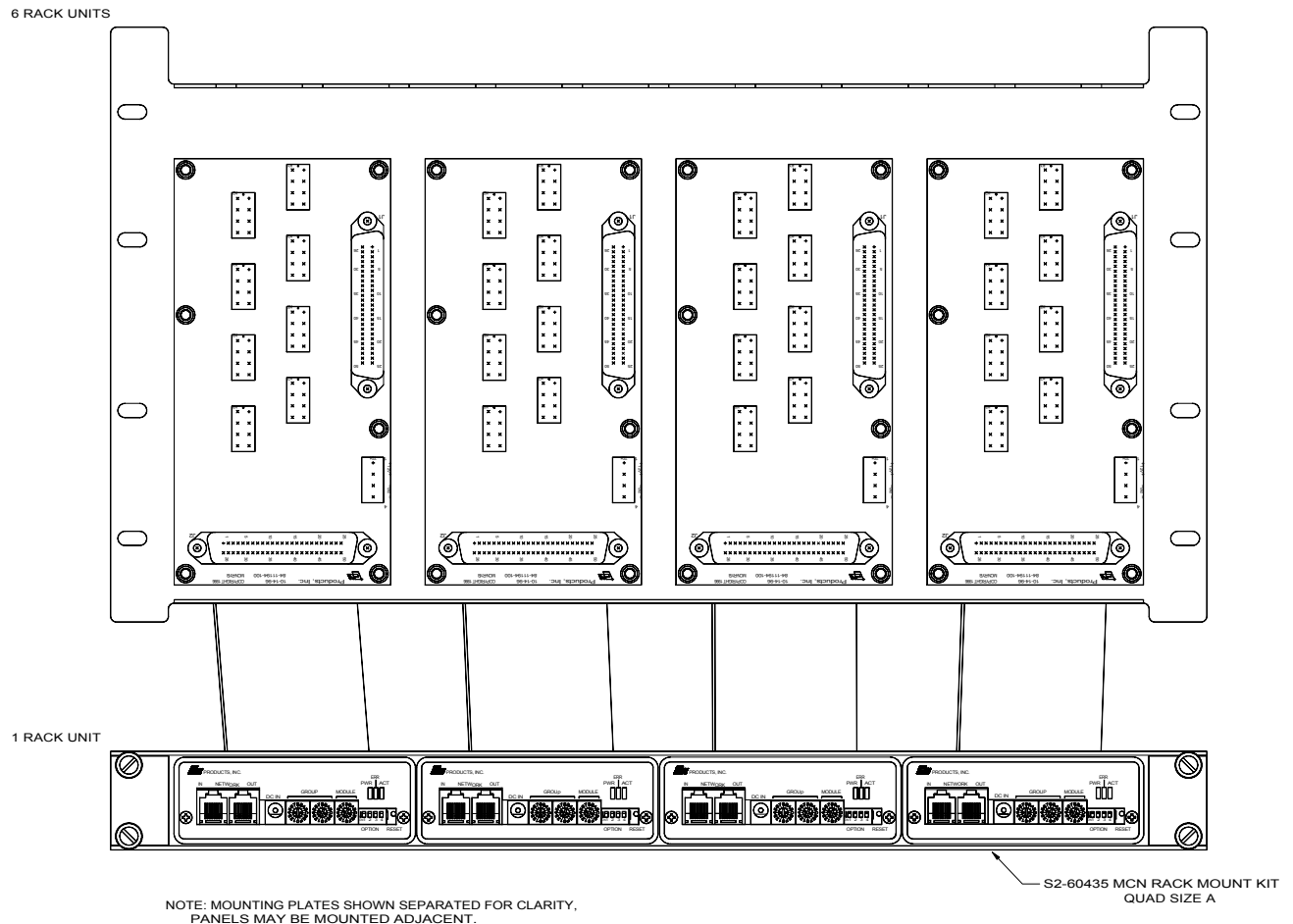

CA-80267-101

Figure 3 Relay Mounting Panel--Rear View

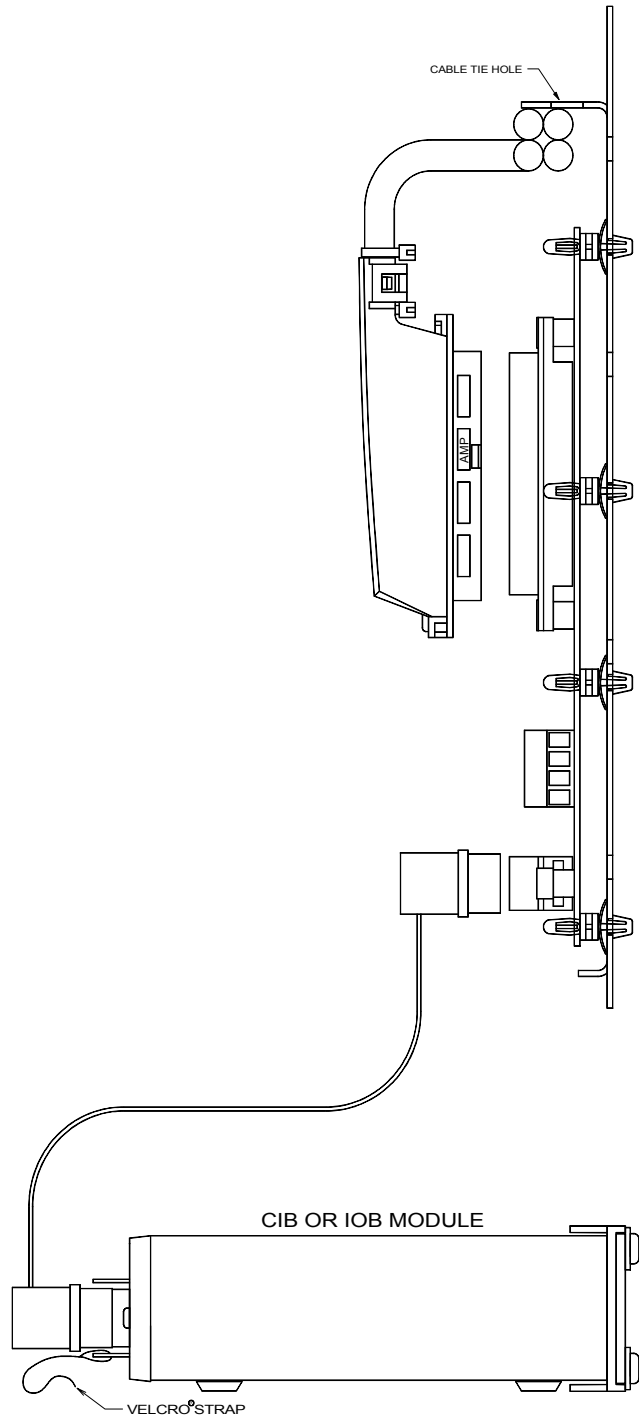

CA-80274-100

Figure 4 Relay Mounting Panel Side

5. Specifications

Relay Circuits	8, DPDT (Dual Form C), Sealed																								
Relay Type	MIL-R-39016/6																								
Contact Type	Gold Plated over Hardened Silver; Stationary contacts are bifurcated																								
Contact rating and life expectancy	<table> <tr> <td>0.5 A</td> <td>@ 28VDC</td> <td>Resistive</td> <td>500,000 Operations</td> </tr> <tr> <td>1.0 A</td> <td>@ 28VDC</td> <td>Resistive</td> <td>250,000 Operations</td> </tr> <tr> <td>2.0 A</td> <td>@ 28VDC</td> <td>Resistive</td> <td>100,000 Operations</td> </tr> <tr> <td>3.0 A</td> <td>@ 28VDC</td> <td>Resistive</td> <td>50,000 Operations</td> </tr> <tr> <td>.16 A</td> <td>@ 28VDC</td> <td>Lamp</td> <td>10,000 Operations</td> </tr> <tr> <td>30 uA</td> <td>@ 50 mVDC</td> <td>Low Level</td> <td>1,000,000 Operations</td> </tr> </table> <p>Relays which are used for intermediate and high-level (above .5A and/or 28 volts), inductive, or lamp service will not be suitable for low-level operation.</p>	0.5 A	@ 28VDC	Resistive	500,000 Operations	1.0 A	@ 28VDC	Resistive	250,000 Operations	2.0 A	@ 28VDC	Resistive	100,000 Operations	3.0 A	@ 28VDC	Resistive	50,000 Operations	.16 A	@ 28VDC	Lamp	10,000 Operations	30 uA	@ 50 mVDC	Low Level	1,000,000 Operations
0.5 A	@ 28VDC	Resistive	500,000 Operations																						
1.0 A	@ 28VDC	Resistive	250,000 Operations																						
2.0 A	@ 28VDC	Resistive	100,000 Operations																						
3.0 A	@ 28VDC	Resistive	50,000 Operations																						
.16 A	@ 28VDC	Lamp	10,000 Operations																						
30 uA	@ 50 mVDC	Low Level	1,000,000 Operations																						
Supply Voltage	12 VDC Nominal (10-15 VDC)																								
Input (Control) Signals:	Active low 88 mA max. @12VDC 110 mA max. @15VDC																								
Supply Current (all 8 relays activated)	704 mA max. @12VDC 880 mA max. @15VDC																								
Operate & Release Time	4.0 ms max. with 12 VDC supply and contact load of 10 mA @ 6VDC																								
Board Size H x W x D	7.5" x 3.75" x 2.5" (mounted with connectors seated)																								
Relay Control (Input) Connector	50-pin Female Micro-ribbon AMP connector (TELCO 25-pair style)																								
Relay Output (Contact) Connector	50-pin Female Micro-ribbon AMP connector (TELCO 25-pair style) with Velcro cable clamp																								
Optional telephone line terminations:	620 Ohm 1/4 W 5%																								
Power Connector:	4-pin screw terminal strip, accepts #24 to #14 AWG wire.																								
Fuse	AGC 1A																								
PCB Flammability Rating:	94V-0																								
Temperature Rating	-25 to +65 Degrees C																								

6. Schematic

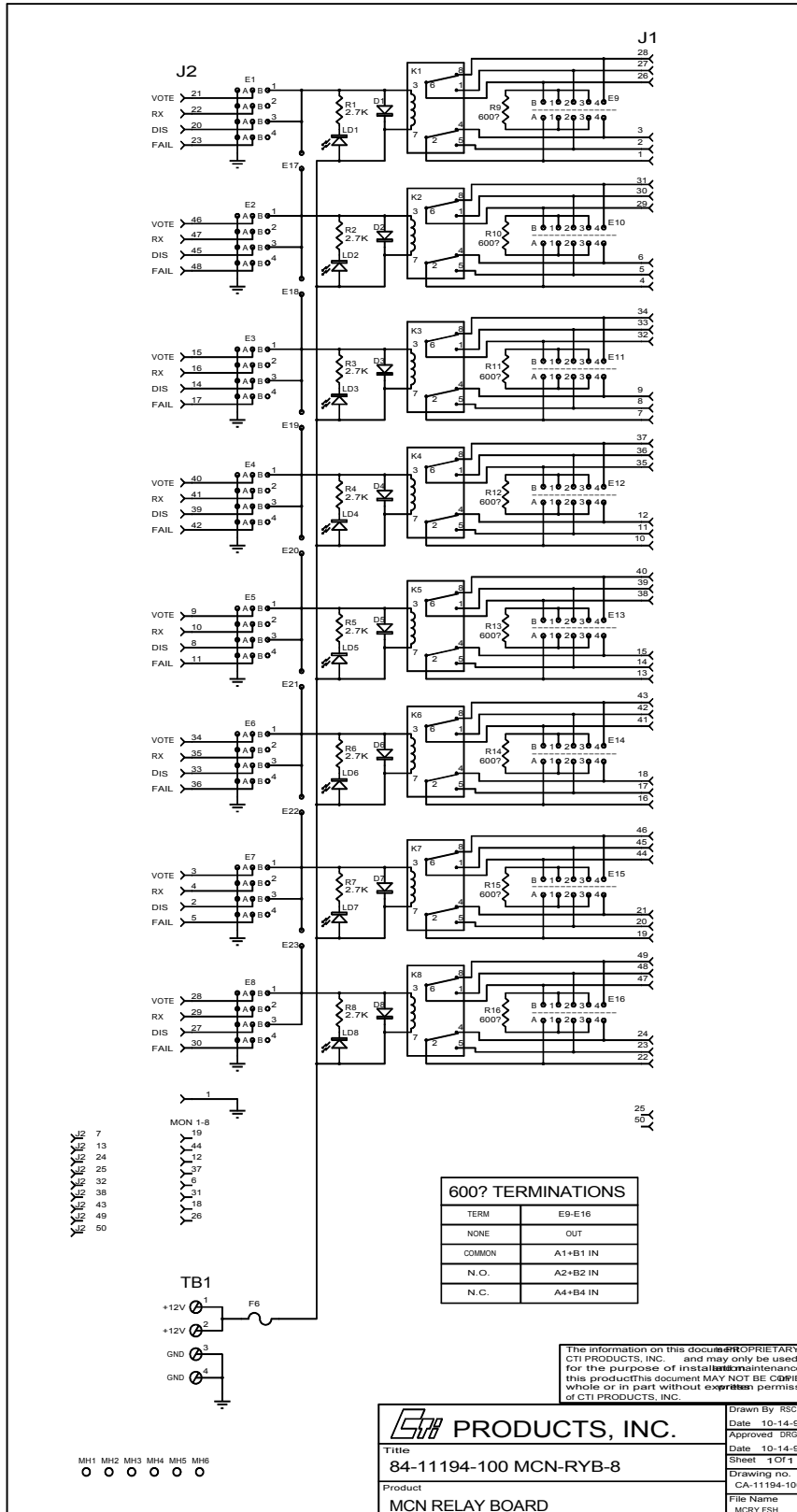

7. Board Layout

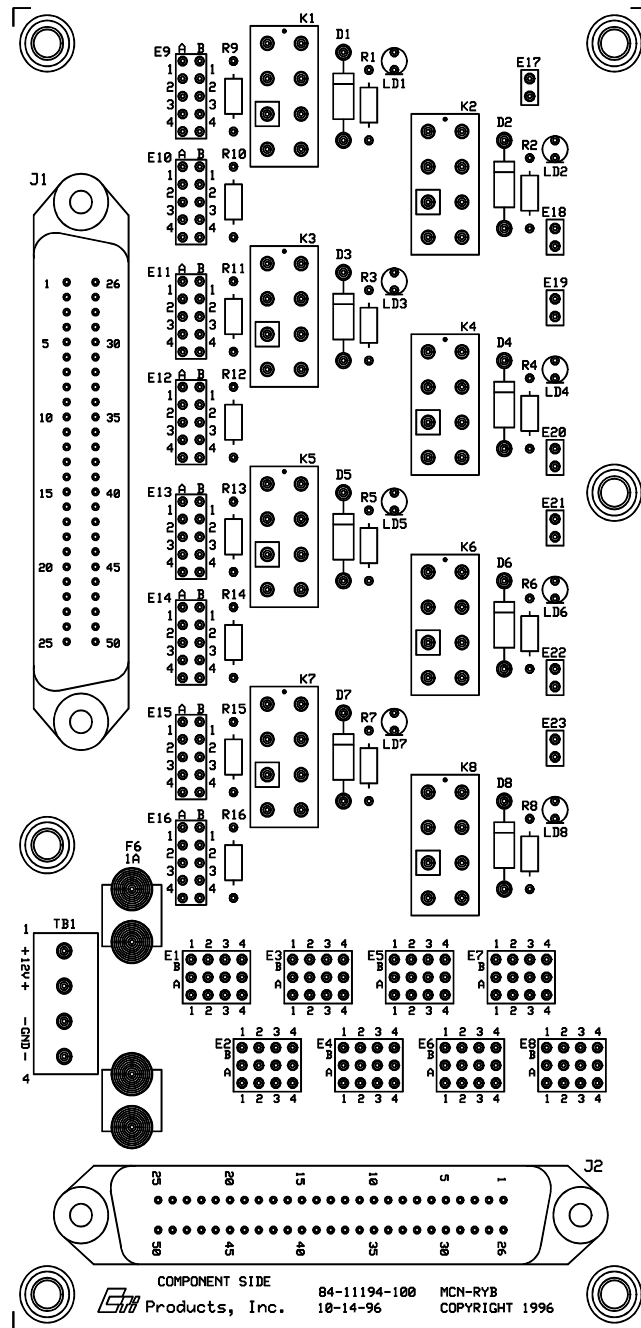

CB-11194.100