

***Monitoring and Control Network
Comparator Display System***

System Manual

S2-60425-120

CTI Products, Inc.
1211 W. Sharon Rd.
Cincinnati, OH 45240

If you have questions about the MCN comparator display system, call us at:
(513) 595-5900. (8:30 to 5:00 Eastern)

Information contained in this document is subject to change without notice and does not represent a commitment on the part of CTI Products, Inc.

No part of this manual may be reproduced or transmitted in any form or by any means, electronic or mechanical, including photocopying and recording, for any purpose without the written permission of CTI Products, Inc.

Copyright 1995, 1996, CTI Products, Inc. All rights reserved.

MCN is a trademark of CTI Products, Inc. ASTRO-TAC is a trademark of Motorola, Inc. Other trademarks referenced are properties of their respective owners.

1. INTRODUCTION AND OVERVIEW.....	1
1.1 MCN SYSTEM ARCHITECTURE.....	1
1.2 REFERENCE DOCUMENTS	2
1.3 MCN SYSTEM COMPONENTS	4
2. COMPARATOR I/O MODULES	6
2.1 ASTRO-TAC™ COMPARATOR INTERFACE MODULE (AIB).....	6
2.2 COMPARATOR INTERFACE MODULE (CIB)	7
3. USER INTERFACE MODULES	8
3.1 HOST COMPUTER INTERFACE MODULE (HIB)	8
3.2 INPUT/OUTPUT INTERFACE MODULE (IIB).....	9
4. AUXILIARY MODULES.....	10
4.1 TSAM INTERFACE MODULE (TIB).....	10
4.2 EXTENDER MODULE (EXB)	10
5. SYSTEM OPERATION	14
5.1 MONITORING AND CONTROL OPERATION	14
5.2 RECEIVER BANKS	16
6. HARDWARE INSTALLATION.....	18
6.1 SETTING THE UNIT ADDRESS.....	19
6.1.1 Address Planning.....	20
6.2 GROUNDING	22
6.3 MOUNTING OPTIONS	23
6.3.1 Wall Mounting	23
6.3.2 Rack Mounting.....	24
6.3.3 CIB DIGITAC Mounting.....	26
6.4 NETWORK CABLING	28
6.5 POWER REQUIREMENTS.....	29
7. MODULE OPERATION.....	31
7.1 MODULE LEDs	31
7.2 MODULE BUTTONS.....	31
8. SYSTEM EXAMPLES	32
8.1 EXAMPLE 1 - 8 RECEIVERS WITH A CONSOLE DISPLAY	32
8.2 EXAMPLE 2 - PC BASED MONITORING AND CONTROL.....	33
8.3 EXAMPLE 3 - 16 RECEIVERS WITH A CONSOLE DISPLAY	34
8.4 EXAMPLE 4 - 24 RECEIVERS WITH MULTIPLE OPERATOR STATIONS	35
8.5 EXAMPLE 5 - STEERED TRANSMITTER SYSTEM	37
8.6 EXAMPLE 6 - CONNECTING NETWORKS IN MULTIPLE BUILDINGS	38

9. CUSTOMER SUPPORT 39

10. TROUBLESHOOTING 40

11. APPENDIX A - UNIT ADDRESS WORKSHEET 42

1. Introduction and Overview

CTI Products' Monitoring and Control Network (MCN™) system provides a modular, scalable system for managing your comparator display requirements. MCN modules connect to your comparator device to provide comparator status monitoring and control. Monitor and control functions can be provided either locally, in the same physical building as the comparator, or remotely over phone lines.

This manual includes sections on MCN system architecture, operation, installation, and troubleshooting. A summary of each MCN module is provided in this manual, while specific features are covered their respective hardware reference manuals. These hardware reference manuals are listed in section 1.2, *Reference Documents*.

Note: All MCN modules are shipped with default switch settings. When installing a module into a system, you must configure the module's switches appropriately for your application. The module's hardware reference manual describes the switches and gives the default switch settings.

1.1 MCN System Architecture

Figure 1 shows a basic MCN comparator display system. The MCN system is made up of two modules, a Comparator I/O Module and a User Interface Module. The Comparator I/O Module provides the hardware interface to the comparator. The User Interface Module provides the mechanism for the user to monitor and control the comparator.

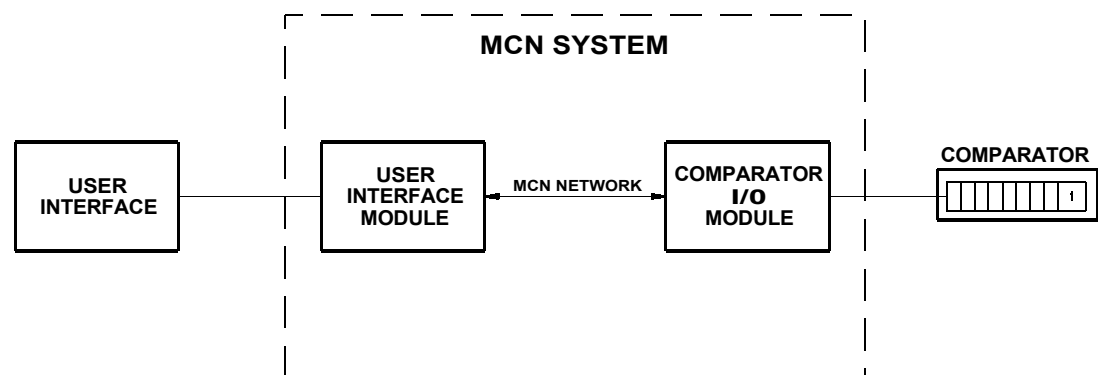

CA-80018-100

Figure 1 - Basic MCN System

The Comparator I/O Module and the User Interface Modules connect with a single cable between the network ports of the modules, simplifying system installation. Large comparator display systems can be built by chaining up to 20 Comparator I/O Modules together in a single network segment. Contact CTI Products for help in designing systems that will require more than 20 Comparator I/O Modules.

The MCN family also includes Auxiliary Modules that provide special control or interface functions, allowing you to expand the capabilities of your comparator display system. For example, your system may have transmitter sites that you want to be able to remotely monitor and control. Section 4 provides a list of all the MCN Auxiliary Modules available. These Auxiliary Modules connect into your comparator display system the same way as the Comparator I/O or User Interface Modules.

Some of the features of the MCN products include:

- Easy RF communications system troubleshooting
- Remote disabling of noise-producing equipment
- Automatic logging of RF system malfunctions with a PC based user interface

Together, the Comparator I/O Module and the User Interface Module provide a simple, cost effective way to control your comparator system. Because of the MCN system's modular design, your comparator display system can easily expand as your communications system grows.

Note: Some modules in the MCN family look alike. The model number label on the rear panel of the module gives the module type information you need to tell each module apart.

1.2 Reference Documents

1. Comparator Interface Module (CIB) Hardware Reference Manual
Part Number S2-60426
2. ASTRO-TAC™ Comparator Interface Module (AIB) Hardware Reference Manual
Part Number S2-60399
3. Input/Output Interface Module (IIB) Hardware Reference Manual
Part Number S2-60400
4. Host Computer Interface Module (HIB) Hardware Reference Manual
Part Number S2-60427

5. MCN RCD Software User Manual
Part Number S2-60428
6. TSAM Interface Module (TIB) Hardware Reference Manual
Part Number S2-60469
7. Extender (EXB) Module User Documentation
Part Number S2-60596
8. Input/Output Control Module (IOB) Hardware Reference Manual
Part Number S2-60630
9. CIB Test Board Hardware Reference Manual
Part Number S2-60651
10. MCN RYB-8 Relay Board
Part Number S2-60657

1.3 MCN System Components

Below is a list of all MCN modules and accessories available to build your comparator display system.

COMPONENT	PART NUMBER
Comparator Interface Module (CIB)	S2-60442
Digitac Mounting Kit and Cable	S2-60437
Dual 25 Pair Punch block	31-10354
Cable to Punch block (10 ft.)	89-10711
Cable to Punch block (25 ft.)	89-10837
Cable to Spectra TAC, TAC, GE (25 ft.) Blunt End	89-10843
ASTRO-TAC™ Comparator Interface Module (AIB) <i>- available exclusively through Motorola, Inc.</i>	S2-60331
AIB to ASTRO-TAC™ Comparator cable (10 ft.)	S2-60440
Input/Output Interface Module (IIB)	S2-60433
Dual 25 Pair Punch block	31-10354
Cable to Punch block (10 ft.)	89-10711
Cable to Punch block (25 ft.)	89-10837
Cable to Blunt End (25 ft.)	89-10843
Host Interface Module (HIB) with MCNRCD DOS Software	S1-60424
Cable Kit (includes cable and adapter for 9 pin or 25 pin comm. ports)	S2-60441
TSAM Interface Module (TIB)	S2-60451
Input/Output Control Module (IOB)	S2-60511
Extender Module (EXB)	S1-60602
Telephone handset with 7 ft coiled cord	S2-60505
CIB Test Board	S1-60601
MCN-RYB-8 Relay Board	S2-60694

COMPONENT	PART NUMBER
Network Cables	
9 inch cable	S2-60438
3 ft. cable	89-10732
10 ft. cable	89-10712
25 ft. cable	89-10835
100 ft. cable	89-10836
100 ft. Plenum cable	S2-60439
Terminator (1 each)	S2-60318
Cable Coupler	27-10841
Power Supplies	
120 VAC U.S. / Canada	81-10398
230 VAC Europe (terminates with an IEC connector)	81-10728
Mounting Kits	
Rack Mount - 4 A size modules	S2-60435
Rack Mount - 2 A size modules plus 1 B size module	S2-60443
Rack Mount - 3 B size modules	S2-60472
Wall Mount - 1 A size module	S2-60444
Wall Mount - 1 B size module	S2-60436

MODULE	SIZE
AIB	A
CIB	A
HIB	A
IIB	A
TIB	A
IOB	A
EXB	B

Table 1 - MCN Module Sizes

2. Comparator I/O Modules

Comparator I/O Modules provide the physical connection between the comparator and the MCN network. Depending on the features provided by the comparator, the connection to the comparator may be discrete I/O points that are hard wired to the comparator, or an RS-232 cable connected to a communications port on the comparator.

The following are CTI Products' MCN Comparator I/O Modules:

- ASTRO-TAC™ Comparator Interface Module (AIB)
- Comparator Interface Module (CIB)

Each module is briefly described below. General information about the operation of each of these modules is provided in this manual. For more information about features specific to an individual module, refer to its hardware reference manual.

2.1 ASTRO-TAC™ Comparator Interface Module (AIB)

The AIB connects Motorola's ASTRO-TAC™ (VSELP signaling) or ASTRO-TAC™ 3000 (APCO Project 25 IMBE signaling) Comparator to the MCN network. This module is available exclusively through Motorola, Inc. Features of the AIB module include:

- Serial communication cable connects the AIB to the ASTRO-TAC™ Comparator.
- Support for up to 13 receivers per AIB when operating with an ASTRO-TAC™ Comparator
- Support for up to 64 receivers per AIB when operating with an ASTRO-TAC™ 3000 Comparator
- Provides VOTE, RECEIVE, DISABLE, and FAIL status for each receiver to an MCN User Interface Module.
- Allows a User Interface Module to FORCE VOTE or DISABLE any receiver.

Refer to the AIB hardware reference manual for a description of the option switches and cable pinout.

NOTE: The HIB User Interface Module only supports 8 receivers of an ASTRO-TAC™ or ASTRO-TAC™ 3000 Comparator.

2.2 Comparator Interface Module (CIB)

The CIB module connects various types of comparators with parallel I/O facilities to the MCN network. Features of the CIB module include:

- Parallel bi-directional I/O line connections between the CIB and a parallel I/O comparator, including Motorola Digitac, Spectra-TAC, TAC, and Ericsson/GE Analog comparators.
- Support for up to 8 receivers per module.
- Provides VOTE, RECEIVE, DISABLE, and FAIL status for each receiver to an MCN User Interface Module.
- Allows a User Interface Module to FORCE VOTE or DISABLE any receiver.
- The CIB can be connected to more than one comparator (with total support for 8 receivers) as long as the comparators are of the same type.
- Interfaces with a TIB module to provide transmitter site monitoring and control (this feature is selected from a front panel option switch).

Option switches on the front panel of the CIB configure the type of comparator being used. Refer to the CIB hardware reference manual for a description of the CIB's option switches.

3. User Interface Modules

An MCN User Interface Module connects the MCN network to various User Interface devices. The user interface may be simple lights and push buttons, such as a console, or the user interface may be a program running on a PC to monitor and control the comparator.

The following are CTI Products' MCN User Interface Modules:

- Host Computer Interface Module (HIB) for PC interface (serial)
- Input/Output Interface Module (IIB) for console interface (parallel)

Each module is briefly described below. General information about the operation of each of these modules is provided in this manual. For more information about features specific to an individual module, refer to its hardware reference manual.

3.1 Host Computer Interface Module (HIB)

The HIB provides a serial interface to a PC and works with CTI Products' Remote Comparator Display (MCNRCD) software to provide comparator monitoring and control. Features of the HIB/MCNRCD combination are:

- Support for up to 512 receivers per system with up to 88 receivers viewable on a single screen.
- Configurable receiver names and screen positions.
- Displays VOTE, RECEIVE, DISABLE and FAIL information for each receiver on the screen.
- FORCE VOTE and DISABLE switch functions are controlled with either a mouse or keyboard.
- Allows logging (to the screen and/or to a disk file) of receivers that fail or become disabled.
- Optional modems allow remote monitoring and control.
- Provides transmitter status monitoring and control for systems that use the TIB module for controlling individual transmitter sites.

Because the module can be used with modems for remote operation, a technician no longer has to travel to the comparator site to diagnose system problems since he can monitor and control the comparator from a PC anywhere there is a dial-up phone line.

3.2 Input/Output Interface Module (IIB)

The IIB provides discrete, parallel I/O points for monitoring and control of your comparator. IIB outputs can be connected to LEDs for viewing comparator status and inputs can be connected to switches for control of comparator functions.

Features of the IIB include:

- Support for up to 8 receivers.
- Outputs for each receiver include RECEIVE and FAIL.
- Bi-directional Inputs/Outputs for each receiver include VOTE and DISABLE.

4. Auxiliary Modules

An MCN Auxiliary Module connects to the MCN network to provide specific control or interface functions.

The following are CTI Products' MCN Auxiliary Modules:

- TSAM Interface Module (TIB)
- Extender Module (EXB)
- Input/Output Control Module (IOB)

Each module is briefly described below. General information about the operation of each of these modules is provided in this manual. For more information about features specific to an individual module, refer to its hardware reference manual.

4.1 TSAM Interface Module (TIB)

The TIB module is a control module that interfaces between an MCN CIB module and CTI Product's Transmitter Steering Audio Matrix (TSAM). This interface provides monitor and control of transmitter sites from a PC connected to an MCN HIB module. The TIB supports up to 8 transmitters.

The TIB is used in systems that have multiple transmitters, with each transmitter associated with one or more receivers that use the TSAM to provide steering for the transmitter sites. The TIB will translate a FORCE VOTE command for a particular receiver into a FORCE TX command that will cause the TSAM to steer to the transmitter associated with the receiver being FORCE VOTED. The TIB also monitors the TSAM for the active transmitter site for display on a PC.

Section 9.5 gives an example monitor and control system that incorporates the TIB and TSAM.

4.2 Extender Module (EXB)

The EXB Module is used in pairs to connect multiple MCN networks that are physically separated. The communication channel used by the EXB can be any analog or digitized analog channel that is capable of carrying V.32 terbo standard modem signaling, including 2-wire or 4-wire leased lines or microwave channels. **The EXB Module does not provide any dialing capability, therefore it cannot be used over dial-up lines.**

EXB modules are used when two multi-node MCN networks are separated by a distance beyond the reach of conventional wired media (typically 4000 feet) and need to be interconnected. This distance could be across a large building, business campus, city, etc. This interconnection is accomplished using one EXB module at each network site and a single voice-grade telephone circuit connecting the two EXB modules. Additional networks can be added to this unified network by simply adding an EXB module pair per network.

Optional handsets can be plugged into the EXB modules to allow simultaneous voice and data between the two locations.

Typical uses include:

- Comparators located remotely plus multiple PC display positions at the local site.
- Comparators at a local and remote site with PC displays at the local and/or remote site.
- In general, any system that requires multiple MCN networks to be connected over phone lines.

See section 9.6 for an example system.

4.3 Input/Output Control Module (IOB)

The IOB Module allows I/O devices (such as relays) to be connected to the MCN network and controlled with a User Interface Module (such as a HIB), creating an I/O control system.

The IOB module has four different operating modes:

1. 16 input and 16 output general purpose I/O lines
2. Two sets of 1 of 4 select outputs plus 24 input lines
3. One set of 1 of 4 select outputs plus 8 input/output lines plus 20 input only lines
4. One set of 1 of 8 select output lines plus 24 input only lines

5. Application Accessories

Application accessories are An MCN Auxiliary Module connects to the MCN network to provide specific control or interface functions.

The following are CTI Products' MCN Application Accessories:

- CIB Test Board (CIBT)
- Relay Control Board (RYB)

Each application accessory is briefly described below. General information about the operation of each of these items is provided in this manual. For more information about features specific to an individual item, refer to its hardware reference manual.

5.1 CIB Test Board

The CIB Test Board (CIBT) is used to test the input and output status signals of the MCN parallel I/O modules. MCN modules compatible with the CIBT include the following:

CIB
IIB
IOB
TIB

The CIBT plugs directly into the rear connector of these modules (J1) for simulation of all monitor and control lines. The switches SW1 through SW32 control the status inputs of the module and LEDs LD1 through LD32 show the output status of the module.

This test board requires an external 18 to 32 Vdc power supply.

5.2 MCN-RYB-8 Relay Board

The MCN-RYB-8 Relay Board provides relay contacts that can be controlled with by the MCN Input/Output Control Module (IOB).

The MCN-RYB-8 board has the following features:

- (8) DPDT Relays (Configured to switch circuit pairs).
- Hi-reliability long-life sealed relays.
- Relays rated for low-level (dry circuit) audio switching, up to 2A.
- Selectable 600 Ohm terminations for the Normally Open, Normally Closed, or Common circuits (may be de-selected).
- LEDs to indicate which relays are active.
- Control Connector (relay coil inputs) which is pin-compatible with the MCN IOB module.
- 25-pair telco connectors used for control inputs and relay outputs.
- Jumpers to control adjacent relays.
- Jumpers for Sub-Category strapping for MCNRCD variable status text messages.
- Optional EIA 19" rack-mount panel available for mounting (4) MCN-RYB-8 boards.

6. System Operation

This section describes the basic operation of both Comparator I/O Modules and User Interface Modules in a comparator display system.

6.1 Monitoring and Control Operation

In an MCN system, the Comparator I/O Module accepts VOTE, RECEIVE, DISABLE, and FAIL receiver status messages from the comparator and sends them to a User Interface Module over the MCN network. User Interface Modules then display the comparator status information on a console or PC.

Likewise, when a User Interface Module sends FORCE VOTE or DISABLE commands, the Comparator I/O Module translates the commands and sends them to the comparator.

MCN modules do not latch the FORCE VOTE or DISABLE controls to the comparator. Any latching required for these signals must be provided by the user interface device. For example, if using a console to control the DISABLE of a receiver, the console switch has to be a latching switch, not a momentary, to keep the DISABLE active after the button is released. The Remote Comparator Display Software running on a PC does provide a latched DISABLE control so that if the right mouse button is used to disable a receiver, the receiver will remain disabled when the right mouse button is released. Pressing the right mouse button a second time will re-enable the receiver.

Figure 2 shows a small system made up of three Comparator I/O Modules (the CIBs) and one User Interface Module (the HIB). The PC can monitor and control all three comparators from a single screen. For this example, assume that all three comparators are Motorola Digitac comparators. When a receiver is force voted from the PC, a FORCE VOTE message is generated by the RCD software and sent to the CIB that is controlling that particular receiver. When the CIB receives the FORCE VOTE message, it will drive the receiver's VOTE output line to signal the comparator that the receiver is being force voted. A similar process occurs when a receiver is disabled from the PC.

Going the other direction, when the comparator detects that a receiver is active, it will drive the RX input of the CIB. The CIB will then generate a RECEIVE message and send it to the HIB so that the active receiver can be shown on the PC screen. A similar process occurs when the comparator generates a Vote (driving the CIB's VOTE input) or a Fail (driving the CIB's FAIL input) signal.

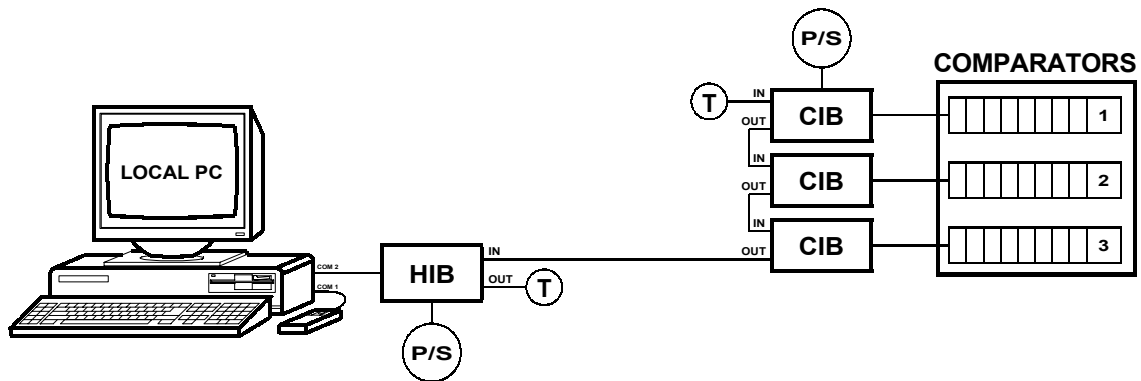

CA-80041-100

Figure 2 - System Operation Example

Bi-directional Lines on IIBs

Because the console VOTE and DISABLE lines are bi-directional, the console's LEDs will be lit if the console's outputs are active. Because of this, the console could still indicate a DISABLE or VOTE on a receiver even if there is a problem in the network cabling or the Comparator I/O Module. Take for example the system shown in Figure 3.

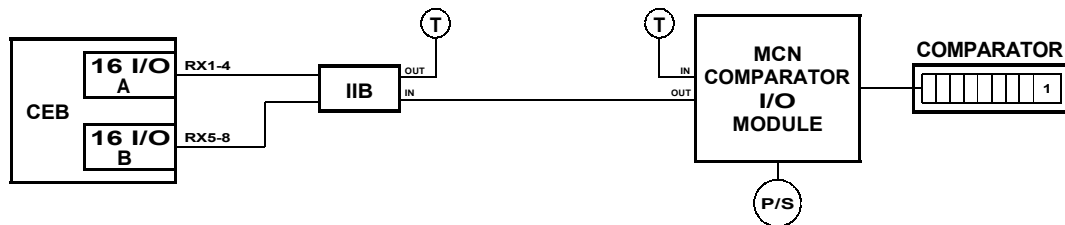

CA-80029-100

Figure 3 - Parallel I/O Monitoring and Control Station

In this system, the VOTE and DISABLE control lines that connect to the 16 I/O cards of the CEB are actually bi-directional signals. Figure 4 shows the interface between the console electronics and the IIB's J1 connector.

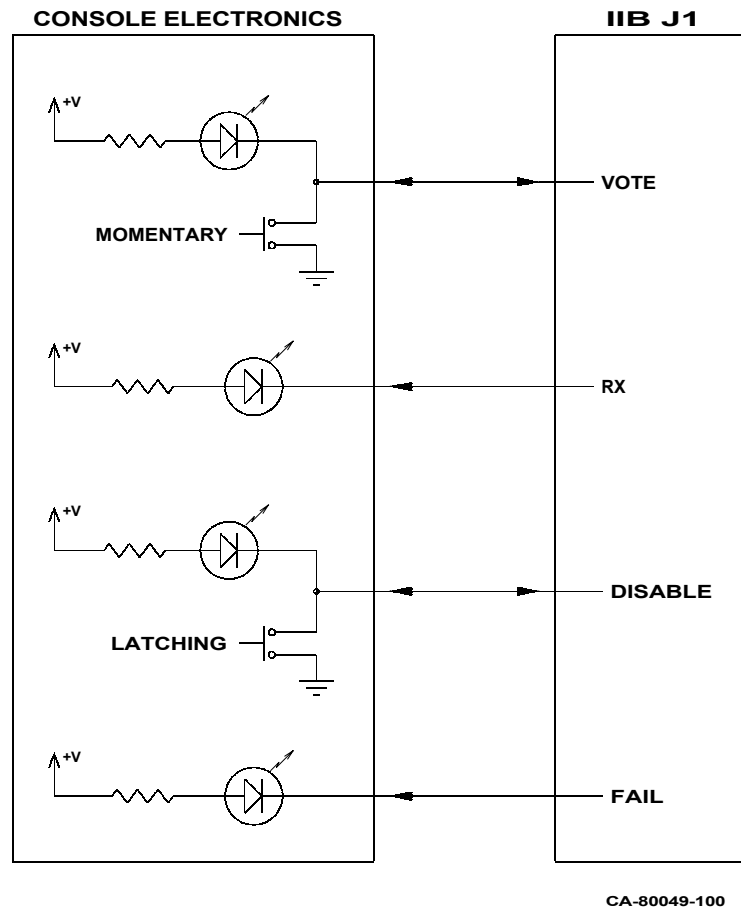

Figure 4 - Console Electronics Interface

When the DISABLE button on the console is pressed, the DISABLE LED on the console will immediately turn on and stay on after the DISABLE button is released since it is a latching button. The IIB will send the DISABLE information to the Comparator I/O Module so that the comparator will disable the receiver. If the DISABLE does not occur (the MCN network is not connected or the receiver is Force Voted so the comparator ignores the DISABLE), the operator at the console may not know it because the console's DISABLE LED is on.

The hardware reference manual of the CIB and IIB indicate which I/O lines are bi-directional and when this type of a problem will occur.

6.2 Receiver Banks

The CIB parallel Comparator Interface Module controls and monitors 8 receivers. The AIB supports up to 13 receivers when configured for an ASTRO-TAC™ Comparator or up to 64 receivers when configured for an ASTRO-TAC™ 3000 Comparator.

For Comparator I/O Modules, such as the AIB module, that support more than 8 receivers, the receivers are grouped into **banks** of 8 receivers. Some User Interface Modules, such as HIBs operating with the MCN Remote Comparator Display software support only bank 0. Other User Interface Modules, such as the IIB, can be configured to control any one of the 8 banks.

Below is a list of the MCN banks and the receivers contained in those banks.

Bank	Receiver Numbers
0	1 through 8
1	9 through 16
2	17 through 24
3	25 through 32
4	33 through 40
5	41 through 48
6	49 through 56
7	57 through 64

Table 2 - MCN Receiver Banks

In the example shown in Figure 5, the ASTRO-TAC™ Comparator supports 13 receivers. The AIB divides the receivers into two banks (receiver banks 0 and 1) for its communications with the User Interface Modules (the IIB modules). Two IIBs are installed in the example system to support these 13 receivers. When the IIBs were installed, each had to be configured (through front panel option switches) for the bank of receivers that each will be monitoring. The first IIB is configured to monitor receivers 1 through 8 (bank 0). The second IIB is configured to monitor receivers 9 through 13 (bank 1). With this configuration, the console can monitor and control receivers 1 through 13.

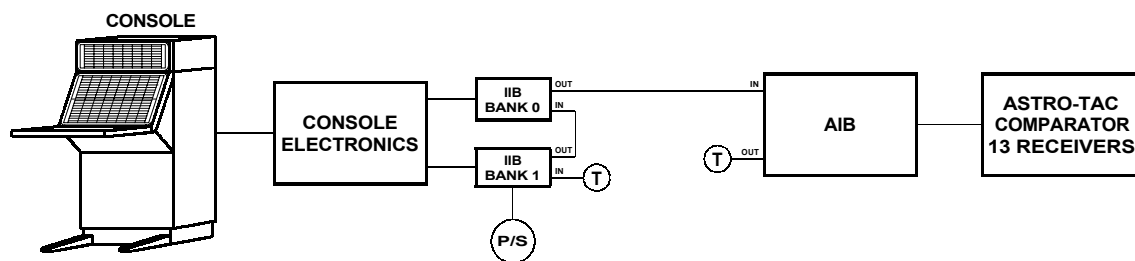

CA-80044-100

Figure 5 - MCN Bank Configuration Example

7. Hardware Installation

This section describes how MCN modules are installed into a system. All MCN modules follow the same basic installation procedure. Some modules may have additional installation requirements. Refer to the module's hardware reference manual for any additional installation information.

Below is a list of steps required for installing an MCN system.

Step	Operation
1	Determine the addresses of all MCN modules. Refer to section 7.1.1, <i>Address Planning</i> .
2	Set Group and Module number for each module. Refer to section 7.1, <i>Setting the Unit Address</i> .
3	Set option switches for each module and Receiver Bank number for IIB modules. Refer to the hardware reference manual of the particular module being installed. Note that the addresses for HIB modules are entered into the PC when the Remote Comparator Display software is installed.
4	Mount all modules at their proper location. Refer to section 7.3, <i>Mounting Options</i> .
5	Route the network cables to connect the modules and install terminators at each end of the network. Refer to section 7.4, <i>Network Cabling</i> .
6	Connect power supplies to the modules. Refer to section 7.5, <i>Power Requirements</i> .
7	Connect the Comparator I/O Modules to their respective comparators. Refer to the module's hardware reference manual.
8	Connect the User Interface Modules to their operator stations. Refer to the module's hardware reference manual.
9	Check the hardware reference manual of each module to see if any additional installation setups are required.
10	Power up the system and verify that, for all modules, the PWR LED is ON, the ACT LED is ON or blinking and the ERR LED is OFF (the ACT LED of an HIB module will blink only if the MCN Remote Comparator Display runtime software is running on the PC and a screen configuration screen is loaded). Refer to section 8.1 for a description of these LEDs.
11	Test the system for proper operation. Refer to section 11 for troubleshooting hints if the system is not working properly.

7.1 Setting the Unit Address

Each MCN module is identified by a unique address that must be set at installation time. This address is specified by the combination of a Group number and a Module number. On all modules (except the HIB) the Group and Module numbers are assigned with the rotary switches on either the front or back of the module. Whenever the Group or Module number is changed, the module must be reset or power cycled for the change to occur.

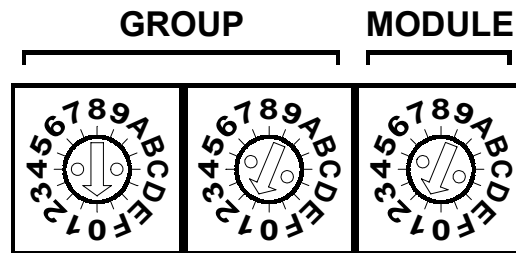

CA-80046-100

Figure 6 - Group and Module Switches

Figure 6 shows a view of the Group and Module switches. Valid ranges of these switches are:

- Group number = 00 through FE
- Module number = 0 through F

Group number FF is reserved and should not be used for any module in the system. If Group number FF is assigned to a module, the module, when reset, will lock on its ERR LED and halt. Other than that restriction, any Group/Module combination can be used for any module. You do not have to have all modules in a system set to the same Group number and you do not have to have like modules set to the same Group number.

Certain MCN modules must have two addresses specified. One is for the MCN module that it will operate with and the other is for the module itself. The IIB and TIB modules require this dual address information. Refer to the IIB's and TIB's hardware reference manuals for details about setting the two addresses.

Note that the addresses for HIB modules are entered into the PC when the Remote Comparator Display software is installed.

CAUTION

All modules in a system must have unique addresses. This address is made up of the Group and Module switches combined. If two or more modules are set to the same address, your system will not work properly and you could have unintended operation.

7.1.1 Address Planning

To help organize the MCN system, we have provided the following guidelines for assigning unit addresses:

- Assign all Comparator I/O Modules to the same Group or set of Groups (if you have more than 16 modules), typically beginning with Group 00, Module 0 and progressing sequentially. Although modules can be added at higher addresses later, if you have plans to expand a channel, you may want to leave a module addresses open for the expansion.
- Assign all User Interface Modules to the same Group or set of Groups (if you have more than 16 modules), beginning with Group 80, Module 0.
- If you have multiple MCN systems in remote locations and you plan to tie them together with a EXB Module, use unique addresses throughout all your systems. Start the Comparator I/O modules and User Interface Modules at each location with new group numbers. This will allow you to connect the systems without re-addressing the modules.
- When using the HIB User Interface Module with the MCN Remote Comparator Display software, only four Groups can be monitored and controlled at a time on one PC. If you are going to be using this User Interface Module, plan the addresses of your Comparator I/O modules so that you use as few different Groups as possible.
- In a large system, you can monitor and control more than 4 Groups on a PC using the HIB; you are just limited to 4 groups simultaneously. For these types of large systems, group your modules so that all the receivers you may want to watch simultaneously are within the same 4 groups.

Figure 7 shows a system that has three Comparator I/O Modules located in comparator room A, two Comparator I/O Modules located in comparator room B, two User Interface Modules located at a maintenance site and two User Interface Modules located in a dispatch room. For this system, all of the modules in a single room are set to the same Group number. All modules in comparator room A are assigned to Group 01. All modules in comparator room B are assigned to Group 02. The User Interface Modules in the dispatch room are set to Group 80. The User Interface Modules at the maintenance site are set to Group 81.

With this setup, all of the Comparator I/O Modules are addressed into two different Groups. This allows plenty of expansion in both comparator rooms, but since only 2 groups are used, it allows the PCs running the MCN Remote Comparator Display Software to monitor and control all receivers in the system from a single screen.

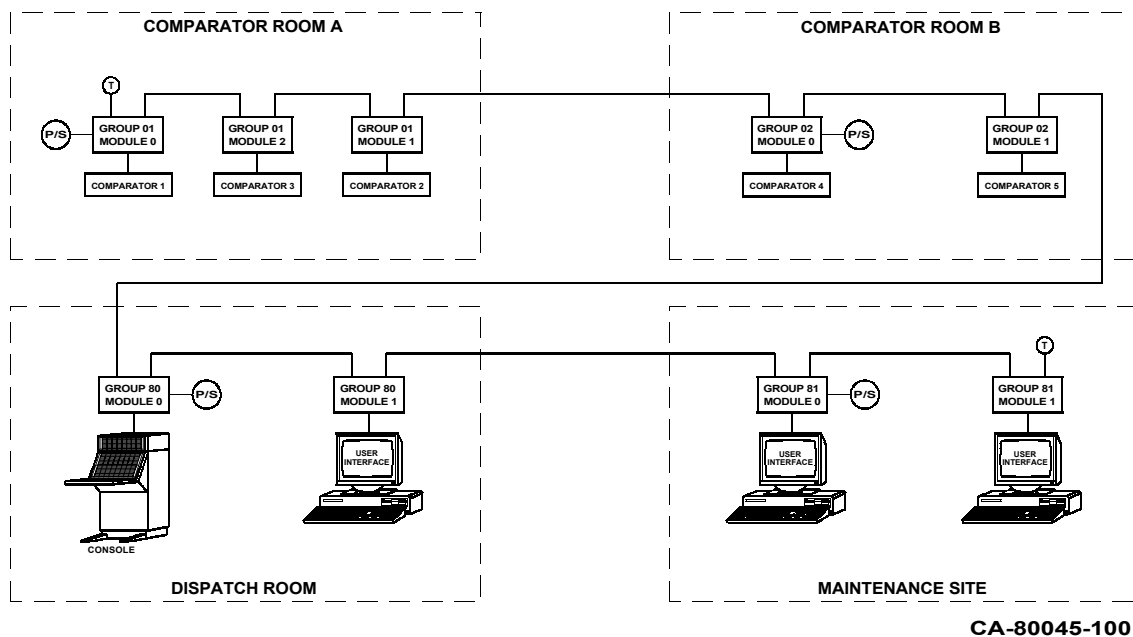

Figure 7 - Unit Address Planning Example

A unit address planning worksheet is provided in *Appendix A - Unit Address Worksheet* that allows you to record the unit addressing information for your comparator display system. Using the system shown in Figure 7 as an example, the worksheet would look like the following:

Unit Type	Group #	Module #	Bank	Group & Module # of associated Comparator I/O Module (For IIB only) Group: Module:	Notes
CIB	01	0	0		Comparator #1 Room A
CIB	01	1	0		Comparator #2 Room A
CIB	01	2	0		Comparator #3 Room A
AIB	02	0	0,1		Comparator #4 Room B
AIB	02	1	0,1		Comparator #5 Room B
IIB	80	0	0 *	02 0	Console Dispatch Room
HIB/RCD	80	1	0		PC #1 Dispatch Room
HIB/RCD	81	0	0		PC #2 Maintenance Site
HIB/RCD	81	1	0		PC #3 Maintenance Site

* You must set the Bank # on the IIBs. CIBs and HIBs are factory-configured for Bank 0 only. AIBs are factory-set for Banks 0 and 1.

With this worksheet, you now have a record of your MCN system configuration, which can help reduce system troubleshooting time.

7.2 Grounding

A chassis ground connection is available on all MCN modules. This connection point is provided by a screw hole that is marked on the bottom of the case.

CAUTION

Make sure that the screw used for grounding and mounting does not protrude into the enclosure more than 1/8 inches from the bottom surface of the module.

Using a larger screw that touches the PC board inside the module may damage the module when it is powered. Doing so will void the unit's warranty.

7.3 Mounting Options

Wall mount and EIA 19" rack mount kits are available for MCN modules. These kits are described below. Some modules may have other mounting options (the CIB module has a special mounting kit that allows the module to be mounted to the back of a Digitac comparator). Any alternate mounting options are described in the specific module's hardware reference manual.

7.3.1 Wall Mounting

The wall mount option allows a module to be mounted to a flat surface. Screw holes are provided on the bottom of all MCN modules for attaching the wall mount bracket(s). Two screw holes are provided on A size MCN modules and four screw holes are provided on B size MCN modules (refer to Table 1, in section 1.3, to determine the size of your module). Simply attach the mounting plate to the bottom of the module using these screw holes and then screw this assembly to the wall. The module can be mounted in any orientation. Figure 8 shows an exploded view of the wall mount installation.

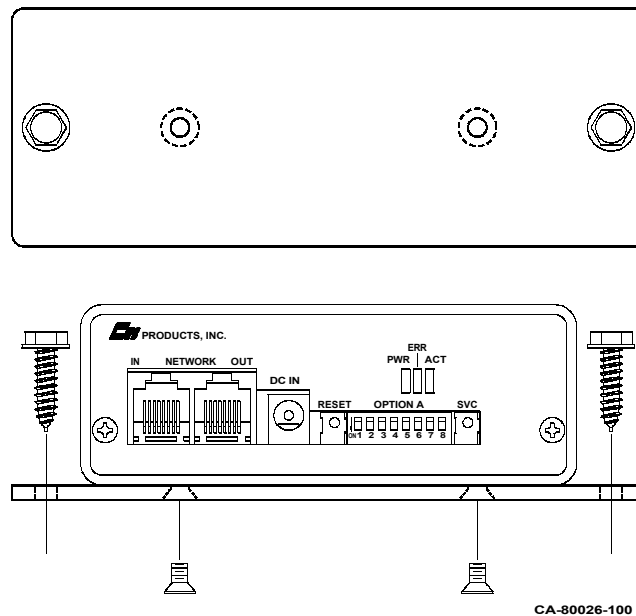

Figure 8 - Wall Mounting

CAUTION

Be sure to use the flat head screws provided with the wall mount kit. If you are not using the wall mount kit from CTI Products, make sure that the screws do not protrude into the enclosure more than 1/8 inches from the bottom surface of the module.

Using a larger screw that touches the PC board inside the module may damage the module. Doing so will void the unit's warranty.

7.3.2 Rack Mounting

The rack mount option provides a 19" rack mounting bracket that supports four MCN modules. Two types of rack mount brackets are available. One supports four A size MCN modules and the other supports two A size and one B size MCN modules (refer to Table 1, in section 1.3, to determine the size of your MCN module). Figure 9 shows an exploded view of the rack mount installation. The top diagram shows the front view of the bracket with one module installed. The bottom two diagrams show a side view of the module installation and bracket installation respectively.

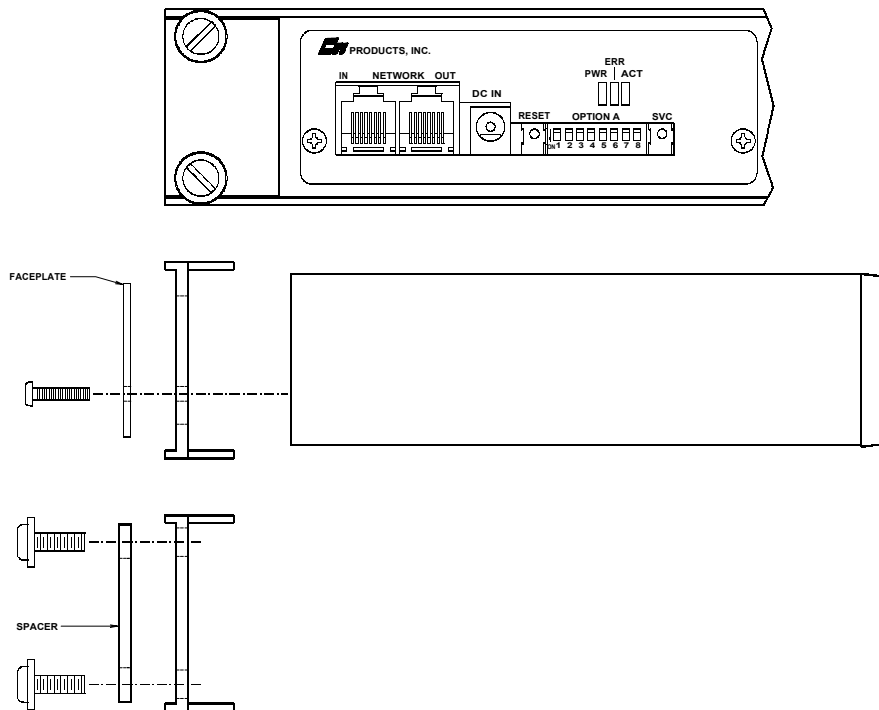

CA-80021-100

Figure 9 - Rack Mounting - Front and Side View

To attach a module to the bracket, and then mount the bracket, follow the steps below.

WARNING

Do not allow the PC board to slide out of the case when the front panel is removed. If it does, **DO NOT** slide the PC board back into the case from the front of the module. Doing so may damage the unit, causing the unit to malfunction when powered on. Doing so will void the unit's warranty.

Rack Mounting Instructions

Step	Operation
1	Remove all cables from the module.
2	Make sure all screws are installed in the back of the module so that the PC board will not be able to slide out of the case when the front panel is removed.
3	Remove the front panel from the module, including the bezel, by removing the two Philips head screws in the faceplate. The bezel is not used when rack mounting the module.
4	Position the module behind the bracket, lining up the holes in the bracket with the front panel screw holes on the module.
5	Position the front panel in front of the bracket, lining the front panel up with the module.
6	Fasten the front panel and module to the bracket with the screws that were previously removed.
7	Position the bracket into your rack, lining up the four mounting holes of the bracket with mounting holes in the rack frame.
8	Position the two spacers in the front of the bracket, aligning the cutouts in the spacers with the holes of the bracket.
9	Install mounting screws (customer provided) into the rack.

When the module's front panel is removed, do not allow the PC board to slide out of the case (this will not happen as long as all screws are installed on the rear panel of the module). If the PC board does slide out of the case, you must follow the steps below to replace the PC board in the case.

Re-Installing a PC Board in its Housing

Step	Operation
1	From the front of the module, slide the PC board out of the case.
2	Remove the back panel of the module.
3	From the rear of the module, slide the PC board back into the case (there are markings on the PC board to indicate which edge to insert into the rear of the case first).
4	Install the back panel of the module.

There is nothing user serviceable inside the modules. Do not attempt to remove the PC board from its enclosure.

7.3.3 CIB DIGITAC Mounting

Figure 10 shows the bracket used to mount the CIB module to the rear of the DIGITAC comparator. This mounting option is only available for the CIB module.

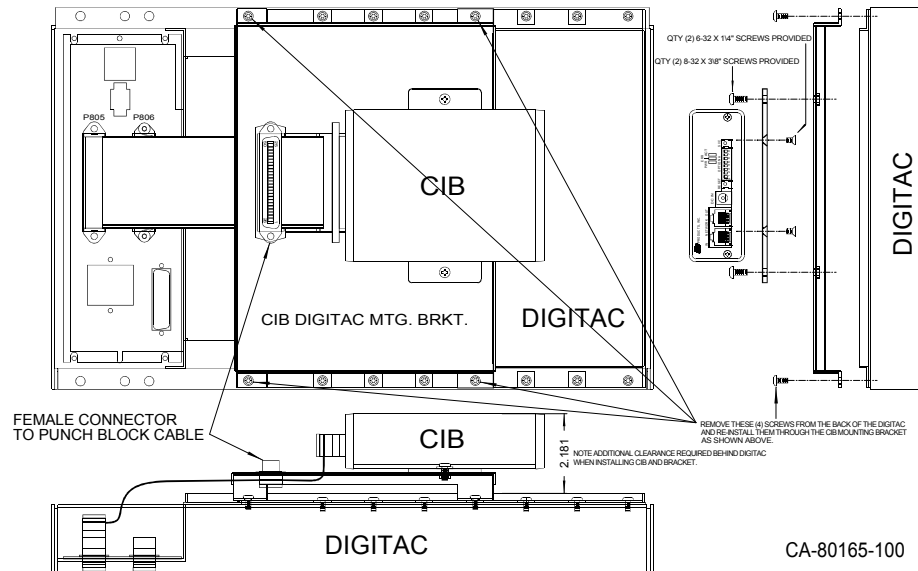

Figure 10 - CIB DIGITAC Mounting Bracket

To attach a CIB module to the bracket, and then mount the bracket, follow the steps below.

WARNING

Be sure to use the screws provided with the DIGITAC bracket kit. If you are not using the screws provided, make sure that the screws used do not protrude into the enclosure more than 1/8 inches from the bottom surface of the module.

Using a larger screw that touches the PC board inside the module may damage the module. Doing so will void the unit's warranty.

DIGITAC Mounting Instructions

Step	Operation
1	Remove all cables from the CIB.
2	Attach the small mounting plate, using the 6-32 X 1/4 screws provided, to the bottom of the CIB module.
3	Attach CIB/plate assembly to the mounting bracket using the 8-32 X 1/4 screws provided.
4	Remove the 4 screws from the back of the DIGITAC, as indicated in Figure 10.
5	Connect the provided cable to the back of the CIB and route the cable underneath the DIGITAC mounting bracket.
6	Position the DIGITAC mounting bracket on the back of the DIGITAC so that the bracket's mounting holes line up with the DIGITAC's screw holes.
7	Re-install the 4 screws (from step 4) in the back of the DIGITAC.
8	Attach other end of the cable to P805 of the DIGITAC.
9	Connect the CIB power and network cables.

With the CIB mounting bracket installed on the back of the DIGITAC, an additional 2.181 inches of clearance is required behind the DIGITAC.

7.4 Network Cabling

MCN modules communicate over a network cable. Specifications for network cabling are the following:

- 4 pair level IV or V unshielded, 24 AWG, twisted pair cable (EIA/TIA 568B).
- Maximum of 20 modules can be connected together in a segment.
- Maximum cable length is 1200 feet.
- Straight through connections.

Figure 11 shows one side of the network cable. This diagram details the pinout and twisted pair configuration of the cable.

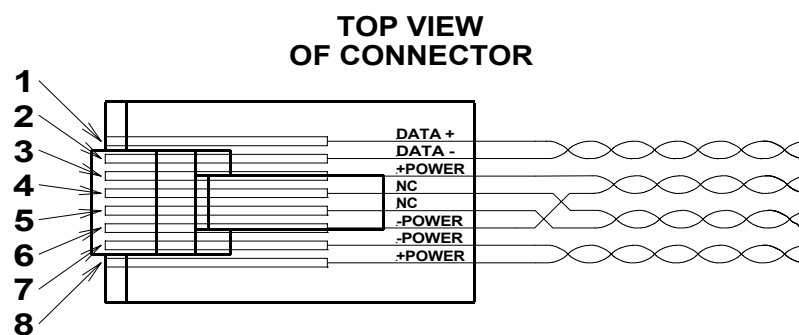

CA-80042-100

Figure 11 - MCN Cable Pinout

When cabling your system, daisy-chain the modules together and insert a network terminator into the unused port of the first module and the unused port of the last module in the chain. An example of what the terminator looks like is shown in Figure 12.

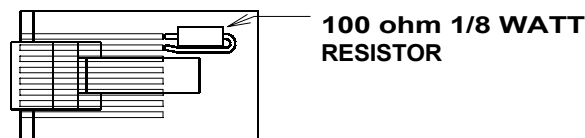

CA-80025-100

Figure 12 - MCN Network Terminator

Use of standard length cables from CTI Products is highly recommended to provide best system performance. Standard lengths up to 100 feet can be combined with cable couplers to create desired length cables. See section 1.3 for

CTI part numbers.

If you do provide your own cable, be sure it meets the specifications above. The system will not work with ordinary telephone cable.

If you are providing your own cable for a run longer than 100 feet, a new power supply will be required at the far end. You may use 2-pair Level IV or Level V cable instead of 4-pair. In this instance, connect just the data pair (Pins 1 & 2).

7.5 Power Requirements

Power input for all MCN modules is 10 to 32 VDC, with most modules requiring no more than 2 W (refer to the module's hardware reference manual for exact input power requirements). CTI Products has plug in power supplies available that provide 18 VDC at 800 mA. MCN systems have been fully tested for appropriate immunity to harmful electrical noise and electrical impulses when assembled with these power supplies only. Operation with other, non-qualified power supplies could yield lower system performance and may void US and Canadian emissions and European emissions and susceptibility approvals.

The DC IN receptacle of all MCN modules can accept either polarity configuration from the input power plug.

The MCN system provides a unique way to distribute power to multiple modules from a single power supply. The network cable used for module communication also contains power lines so that the power from a power supply can be distributed along with the communication lines. The limits of this power distribution are the following:

- A maximum of four modules can be powered from a single power supply.
- The maximum cable length between the modules that share a power supply is 100 feet.

Note: The EXB module, because of its higher power requirements, counts as two module loads when distributing power through the network cable. Therefore, one power supply could be used to power one EXB module plus two other modules.

To create this power distribution (refer to Figure 13), simply connect the power supply into your first module. Then, connect the NETWORK OUT port of that module to the NETWORK IN port of the next module. Continue connecting NETWORK OUT ports to NETWORK IN ports until all modules are connected. If you need to add more power supplies to the system due to power distribution limits, simply connect another power supply into the DC IN port of a module. This new power supply then provides power for the module it is connected to as well as all modules from that module's NETWORK OUT port or until another

power supply is encountered.

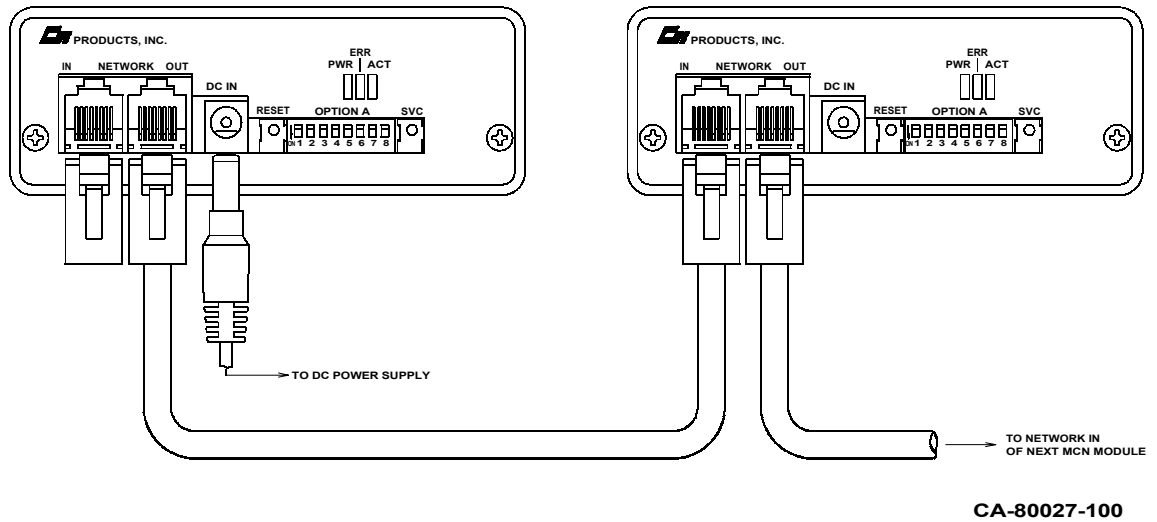

Figure 13 - DC Power Chaining

In the example shown in Figure 14, two power supplies are required, even though there are only four modules in the system. The second supply is required because the network cable between the third and fourth modules is greater than the 100 foot cable length maximum for power distribution.

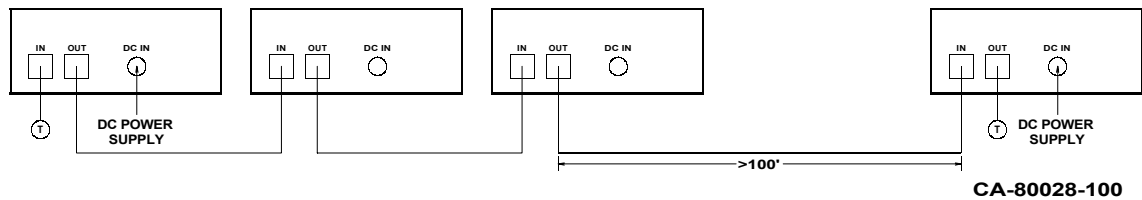

Figure 14 - Power Distribution Example

8. Module Operation

The following sections describe features and functions common to all MCN modules.

8.1 Module LEDs

All MCN modules have three indicator LEDs on the front panel. These LEDs give the following indications:

PWR	ON when the module has DC input voltage within specification. This LED will blink if the input voltage falls below the minimum specified input voltage level. The module may still function in this condition (depending upon how low the DC input voltage is), however this is not recommended.
ERR	ON to indicate module errors. Refer to the module's hardware reference manual for a description of these error conditions.
ACT	ON or blinking to indicate that the module is successfully communicating with other modules over the network.

During normal system operation, the PWR LED should be on, the ACT LED should be ON or blinking, and the ERR LED should be OFF. If the LEDs do not match this after the system is installed, refer to section 11 for troubleshooting hints.

8.2 Module Buttons

All modules are equipped with a **RESET** button. Pressing this button will force the module to initialize itself by reading its configuration switches and to begin communicating with other modules.

Some modules are equipped with a **SVC** button. This button is reserved and should not be pressed during normal operation.

9. System Examples

The following examples show how MCN modules are combined to form various systems, as well as the capabilities of those systems.

9.1 Example 1 - 8 Receivers with a Console Display

Figure 15 shows an MCN system that provides monitoring and control of up to 8 receivers connected to a Motorola ASTRO-TAC™ Comparator. Only 8 receivers are supported because only one IIB module is in the system. To control all 13 receivers of the comparator, you would simply add another IIB module to the system and connect this IIB to the console. This additional IIB has to be configured to operate with receivers 9 through 13.

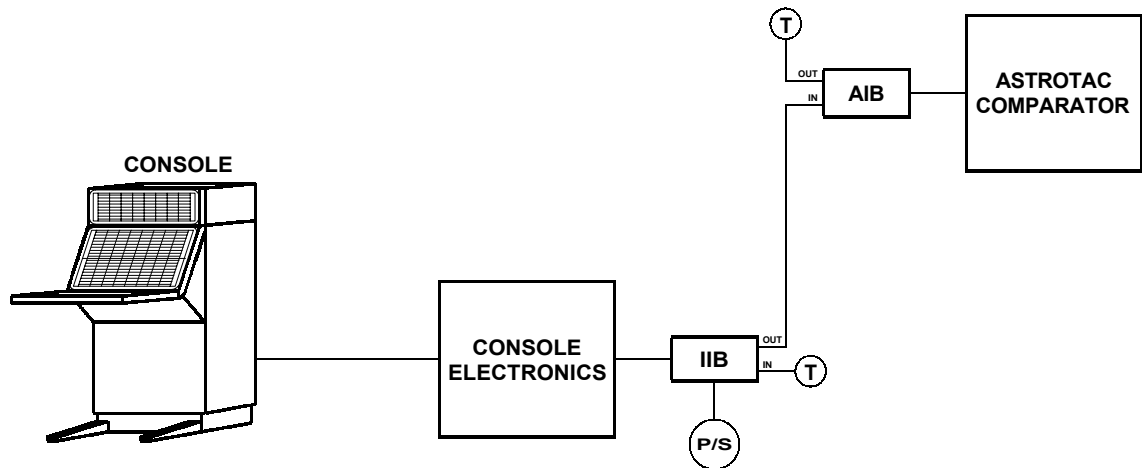

CA-80016-100

Figure 15 - 8 ASTRO-TAC™ Receivers with Console Display

9.2 Example 2 - PC Based Monitoring and Control

Figure 16 shows a system that provides local monitoring and control of up to 8 receivers utilizing a PC as the operator interface. CTI Product's Remote Comparator Display software running on the PC allows each receiver of the comparator to be individually controlled.

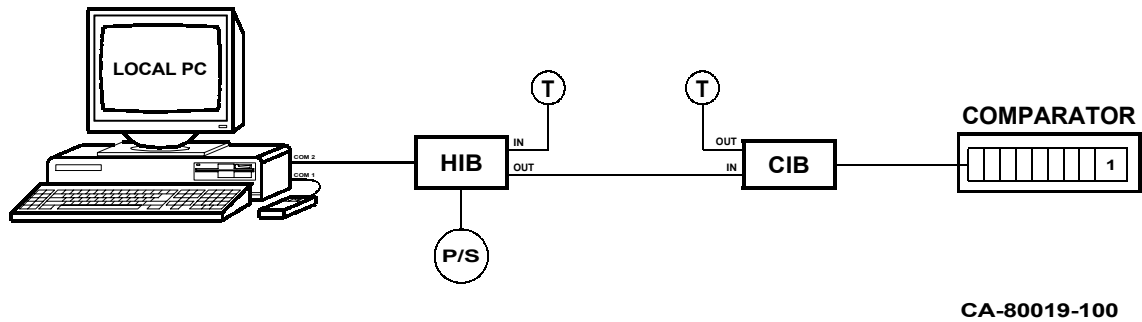

Figure 16 - 8 Receivers with PC Display

The Remote Comparator Display Software will also work with AIBs and ASTRO-TACT™ Comparators with up to 8 receivers per comparator.

9.3 Example 3 - 16 Receivers with a Console Display

A multiple comparator system is shown in Figure 17. This system implements monitoring and control of 3 different comparators from one console.

Notice that in this system, one CIB module is being used to control receivers from two comparators (comparators 1 and 2). The only requirement for this setup is that both comparators 1 and 2 are the same type (i.e. both must be Digitac or both must be Spectra TAC, etc.). Comparator 3 does not have to be the same type as comparators 1 and 2 since it connects to a different CIB.

This example will provide control for up to 16 receivers total.

A benefit of this system is that all of the parallel I/O lines between the comparators and the console electronics do not have to be run the 400 ft. distance between the console electronics and the comparators. Only a single network cable for the MCN system has to be run the 400 ft.

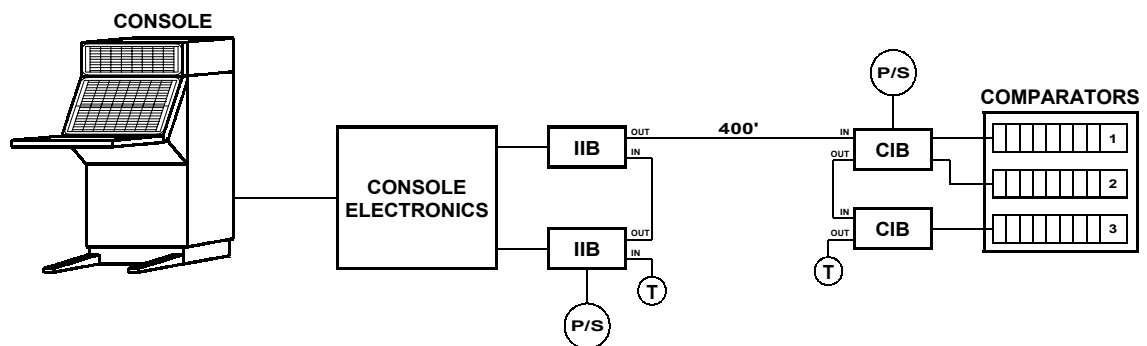

CA-80020-100

Figure 17 - 16 Receivers with Console Display

9.4 Example 4 - 24 Receivers with Multiple Operator Stations

The example in Figure 18 shows a much larger system than the previous examples. Three CIB modules are used to control a total of 24 receivers. The three IIB modules can be used to provide control of all receivers from the main console. Each PC in the system can control all receivers as well. The HIB modules provide both local and remote control of all receivers. With the HIB connected directly to the modem, the comparators can be accessed from anywhere that has a dial-up phone line.

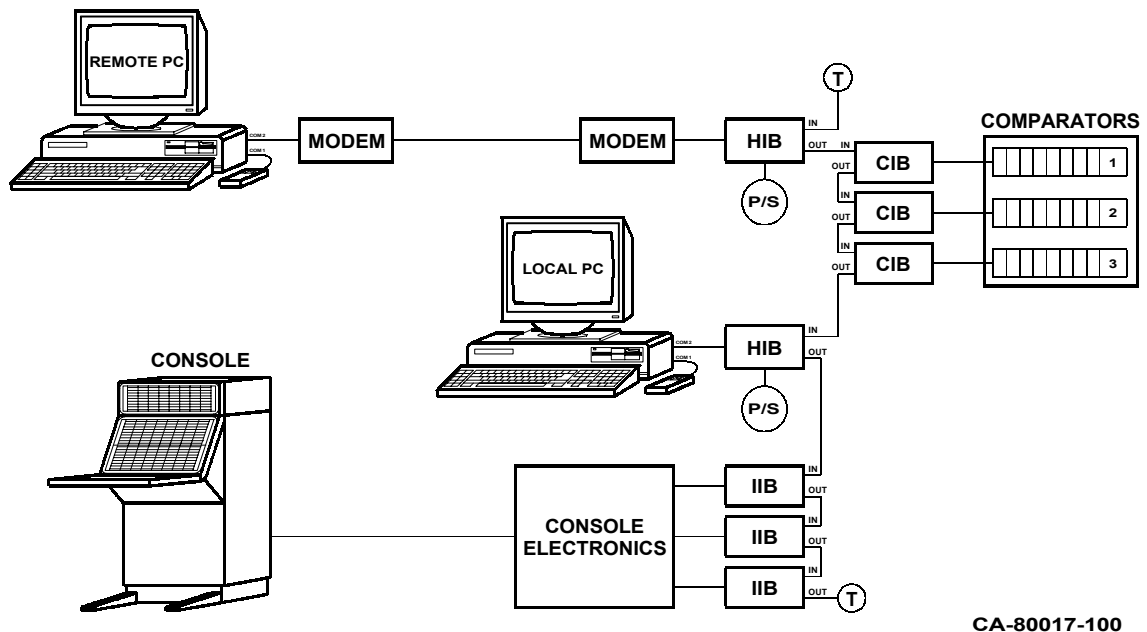

CA-80017-100

Figure 18 - 24 Receivers with Multiple Operator Stations

Power can be provided to this MCN system from two power supplies, as long as the network cables are connected properly for power distribution. One supply could power one HIB module and all three CIB modules. Another supply could power the other HIB module and the three IIB modules.

This system allows parallel status and control of three comparators from three operator locations. If an operator at one station force votes a receiver, the other two operator stations will show that receiver as voted. Or, if an operator at one station disables a receiver, all other operator stations will also show that receiver as disabled. If one of the comparators signals that a receiver is voted, all three stations will show the receiver being voted.

There is one limitation of a system which uses both HIBs and IIBs together to control the same comparator. If a receiver is disabled from the console (this is a latched disable), the two PC displays will report the receiver as disabled when the comparator disables that receiver. If one of the PCs then re-enables that receiver, the comparator will enable the receiver and both PC displays will show the receiver as enabled, but the console will still indicate that the receiver is disabled because the console has a latched disable (the console LED is controlled by the disable switch).

9.5 Example 5 - Steered Transmitter System

Figure 19 shows an example system using the TIB module with a TSAM to provide transmitter steering as well as comparator monitoring and control.

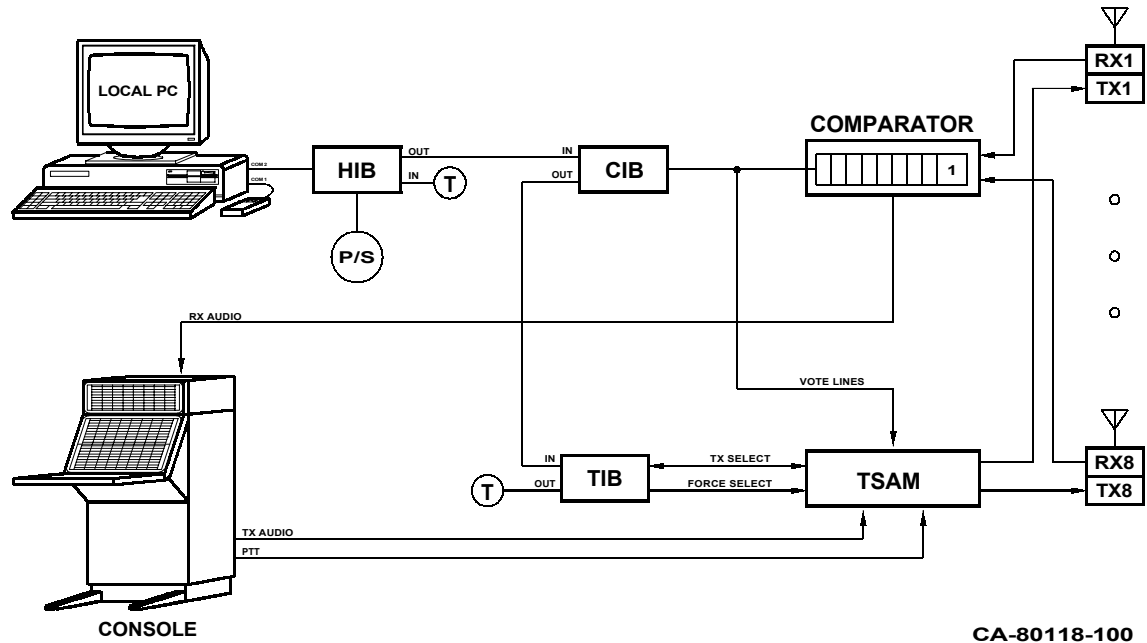

Figure 19 - TIB System Example

For the system shown in the figure, note the following:

- The system receivers are connected to the comparator
- The system transmitters are connected to the TSAM
- The comparator's vote lines are connected to the CIB and to the TSAM (this allows the TSAM to steer based on receiver activity and comparator voting)

Assume initially that all receivers are inactive and that the TSAM is programmed for Instant Update mode (the TSAM will steer as soon as a vote occurs). When receiver 8 becomes active, the comparator will vote receiver 8, activating the receiver 8 vote output. The TSAM sees this vote change, since it is monitoring the comparator's vote outputs, and steers to transmitter 8 (since it is programmed for Instant Update mode). The TSAM updates the Tx Select lines to indicate that transmitter 8 is active. The TIB detects the change on these lines and sends a message to the MCN modules indicating that transmitter 8 is the currently active transmitter. The HIB receives this steered transmitter information and updates the PC's receiver 8 display information to show that it is the active transmitter. The CIB will also detect the receiver 8 vote status and generate a VOTE message to the HIB. Thus, the HIB will receive status messages indicating that receiver 8 is voted and that transmitter 8 is active. Both of these states will be shown on the

operator's PC.

To force the TSAM to steer to transmitter 1, the operator will generate a FORCE VOTE for receiver 1. The TIB will receive this FORCE VOTE for receiver 1 and setup the Tx Select lines for transmitter 1 and the Force Select line. When the TIB activates the Force Select line to the TSAM, the TSAM will immediately steer to transmitter 1. The FORCE VOTE for receiver 1 will also cause the CIB to generate a FORCE VOTE command to the comparator.

9.6 Example 6 - Connecting Networks in Multiple Buildings

Figure 20 shows an example system using two EXB modules to connect a monitoring and control system that has the comparators and the console located in different buildings.

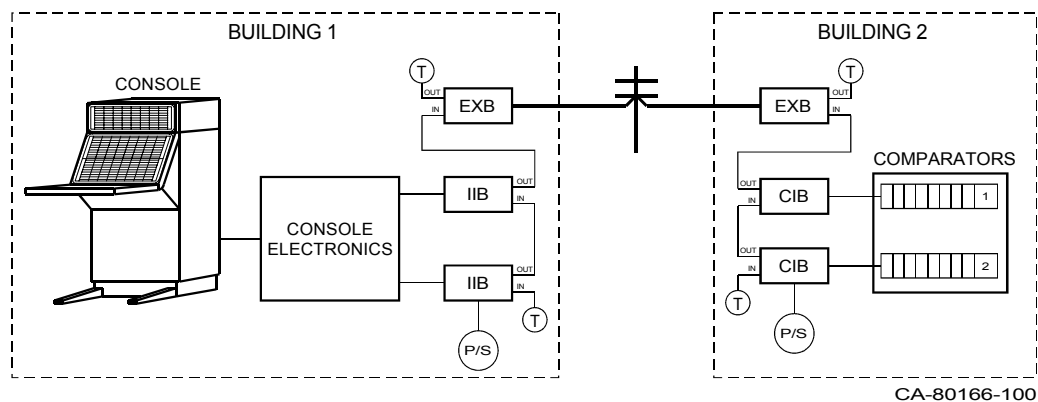

Figure 20 - MCN module in two buildings connected with EXB Modules

This system extends the comparator status and control lines to a console located more than 4000 feet away. It performs a “logical extender” function.

The EXB modules are used to connect the IIB modules with the CIB modules. The EXB connection can be either a 2 wire or 4 wire leased line. No programming is required for the EXB. Simply set the option switches as specified in reference 7, connect the EXBs to the leased line, and power on the modules. The EXBs will automatically begin training and once the link is established, begin passing data.

An optional handset could be plugged into each EXB to allow the personnel in building 1 to talk to personnel in building 2 while the comparator display system is functioning.

10. Customer Support

If you need help in setting up your system, call one of our engineers at:

(513) 595-5900.

Ask to speak to a CTI Products engineer. Our hours are from 8:30 to 5:00 Eastern time.

If you are calling about a problem with a specific module, please have the module's model name, model number and serial number available when you call.

11. Troubleshooting

Below is a table listing some common problems encountered with MCN modules. If, after using this diagnostic table, you still have a problem, check the module's hardware reference manual to see if there are any other troubleshooting guides that are specific to the module.

PROBLEMS	CAUSES
PWR LED is off	<p>If using a power supply, make sure it is plugged into the DC IN port of the module. Also, make sure the power supply is plugged into the wall outlet.</p> <p>If power is being supplied over the network cable, make sure that the network cable is properly connected between NETWORK OUT ports and NETWORK IN ports as specified in section 7.4.</p>
PWR LED is blinking	<p>This indicates low voltage. Plug a power supply directly into the DC IN port and see if the PWR LED stops blinking. If so, make sure that the system's power distribution requirements are met as stated in section 7.5.</p>
ERR LED is blinking	<p>Reset the module. If LED still blinks, call CTI Products' customer support.</p>
ERR LED is on	<p>Verify that the module's Group and Module numbers are valid (refer to section 7.1). Correct them if necessary, then press the reset button.</p> <p>Verify that the option switches are set properly. Refer to the module's hardware reference manual for a description of the option switches. Correct them if necessary, then press the reset button.</p>
ACT LED is off	<p>Verify that the module's Group and Module numbers were properly assigned and set.</p> <p>Check the network cables and make sure they are fully inserted into the receptacle.</p> <p>Make sure that the terminators are installed (refer to section 7.4).</p> <p>Note: The ACT LED of the HIB module will only blink if a PC that is running the MCN Remote Comparator Display runtime software is running and a screen configuration file is loaded.</p>

PROBLEMS	CAUSES
<p>System does not correctly display the VOTE, RECEIVE, DISABLE, or FAIL status of a receiver</p> <p style="text-align: center;">OR</p> <p>System does not correctly FORCE VOTE or DISABLE a receiver</p>	<p>Verify that all wiring between the Comparator I/O Module and the comparator is correct.</p> <p>Verify that all wiring between the User Interface Module and the operator station is correct.</p> <p>Verify that all unit addresses were set correctly.</p> <p>Verify option switch settings on all modules.</p> <p>Verify that the total system cable length is less than the maximum specified in section 7.4.</p> <p>Verify that the total number of MCN modules in the system is less than the maximum specified in section 7.4.</p>

